

**PIPE SUPPORTS  
AND HANGERS**





# CONTENTS

0	Introduction	2
1	Supports	6
2	Guides	42
3	Pipe attachments – clamps and U-bolts	64
4	Hanger rods – threaded connecting elements	81
5	Structural attachment elements	93
6	Support plates, trapezes	103
7	Rigid struts	122
8	Supports for non-metallic pipelines	134
9	General technical information	155

# INTRODUCTION

The design of Moravia Systems supports and hangers is based on twenty years of experience in piping design and the knowledge of operational reliability of piping systems.

Supports and hangers are devices that connect a pipe or other parts of a piping system to a supporting or foundational structure. They must provide a transfer of forces and specific movement, i.e. free movement or its accurate limitation. The Moravia Systems production catalogue offers an optimized selection of standard components, which can be used to create a support assembly with required function. The design of components has been performed in such a way that it is possible to build up a restraint of required type for every real situation.

The catalogue offers versatility and helps minimize the number of components for selection, which provides confidence during the process of design and operation of the pipe support.

The production of Moravia Systems is based on a well-known and proven design, but it has been modified and optimized.

All components have been designed with respect to the following:

- Load-bearing capacity - documented according to EN 13480: 2017, ASME B31.1 and B31.3;
- Weight - Moravia Systems pipe supports and hangers are lighter in weight compared to older designs, which results in lower costs and savings in transport and assembly.
- Functional features - it ensures reliable function while eliminating possible mistakes during assembly and operation.



## OVERVIEW OF MORAVIA SYSTEMS PRODUCTS

1. **Spring hangers and supports - we supply assemblies with variable and constant effort spring units from Lisega. Hanger rods, U-bolts, clamps and supports come from our own production facilities.**
2. Rod hangers - we supply complete assemblies of our own production.
3. Supports and guides - large selection of standard designs of our own production.
4. Structural attachment elements - large selection of standard elements of our own production.

5. Supports for plastic, pre-insulated and cryogenic piping - support assemblies with slide plates or rollers.

In terms of application parameters, the catalogue covers the following pipe support for:

- Pipes of nominal size **DN from 15 mm to 800 mm**;
- Piping of the following materials: carbon steel, Cr-Mo steel, austenitic steel, polyethylene (PE) and polypropylene (PP), GRP;
- Piping with working temperature **from -180 °C to +700 °C**;
- Ambient temperature **from -50 °C to +200 °C**;
- Load up to **500 kN**.

In terms of production standards, the catalogue covers the following piping systems:

- All piping designed and constructed in accordance with the European Pressure Equipment Directive (PED);
- Metallic industrial piping designed according to EN 13480, all design classes;
- Boiler piping, headers and manifolds designed according to EN 12952;
- Piping designed according to EN 1993-4-3 regulations for steel structures;
- Piping designed in accordance with European regulations for gases and long-distance liquid or heat pipelines;
- Piping for power, chemical and petrochemical industries designed according to ASME B31.1 and B31.3, with further reference to MSS SP-58 and MSS SP-69;
- Boiler piping according to ASME Section I;
- Process piping according to ПБ 03-585-03;
- Steam and hot water piping according to ПБ 03-573-03;
- Boiler piping, according to ПБ 10-574-03;
- Non-metallic piping, such as polypropylene (PP), polyethylene (PE) and fiberglass reinforced plastic (GRP).

## PRODUCTION

The Moravia Systems production plant in Vracov, Czech Republic has facilities for material forming and cutting, welding and assembly. The total area is 2 000 m<sup>2</sup>.

Our products are made from materials according to EN and ASME standards - carbon, alloy and stainless steels.

Surface finish is provided by coating or galvanizing so that requirements for corrosive aggressiveness of environment up to the degree C5, according to EN ISO 12944, are met.

Packaging is carried out as per requirements specified by our clients, including overseas design of crates with protection against corrosion and paint damage that may be caused by transport impacts.







## QUALITY

Quality management systems are implemented in production, according to EN ISO 3834-2, EN 1090-2 and MSS-SP 58.

Moravia Systems is certified for welding of steel structures, according to EN ISO 3834-2.

## ADDITIONAL SERVICES WE OFFER

### Stress and flexibility analysis of piping systems

- Calculations according to EN13480, ASME B31.1 and ASME B31.3;
- Optimization of pipe routing with respect to thermal expansion and loading of connected equipment (turbines, pumps, compressors, pressure vessel nozzles, etc.);

- Static, dynamic calculations, vibration analysis, piping with two-phase flow;
- Calculations for metallic and non-metallic piping (GRP, HDPE, PP).

### Documentation for piping layout projects

- Development of piping isometric drawings;
- Material specifications, support and hanger specifications.

### Preparation of design and drawings of pipe support and hanger assemblies

- Time-effective preparation of documentation from dwg component libraries;
- Calculations of auxiliary structures according to EN 1993.



SUPPORT ASSEMBLIES AND THEIR STRUCTURAL AND PIPE ATTACHMENTS

PIPE ATTACHMENT ELEMENTS

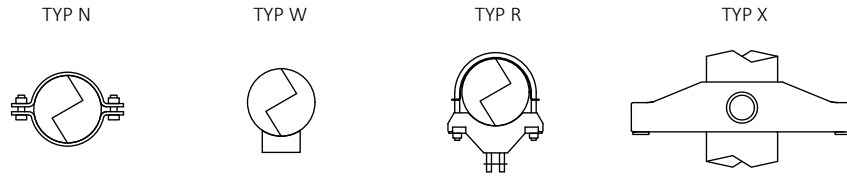

SUPPORTS, GUIDES

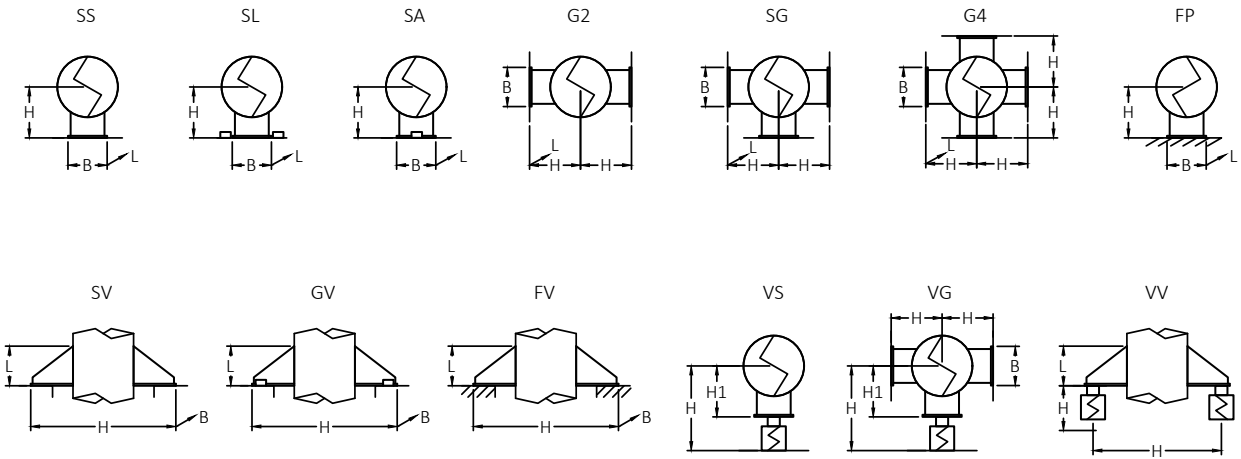

ANGULATED SUPPORTS AND STRUTS

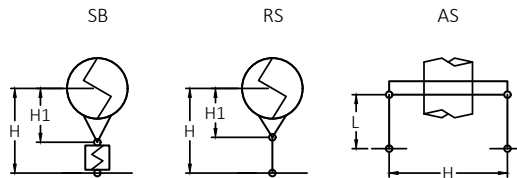

STRUCTURAL ATTACHMENT ELEMENTS

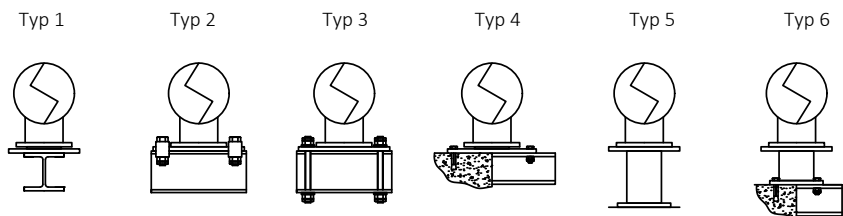

HANGER ASSEMBLIES AND THEIR STRUCTURAL AND PIPE ATTACHMENTS

STRUCTURAL ATTACHMENT ELEMENTS

Typ 1

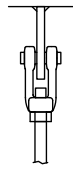

Typ 2

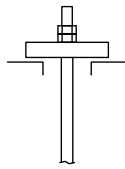

Typ 3

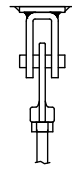

Typ 4

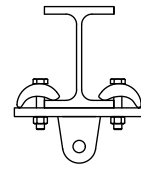

ROD HANGERS

HR1

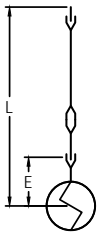

HR2

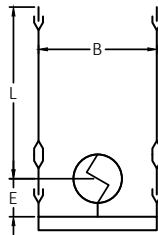

HR3

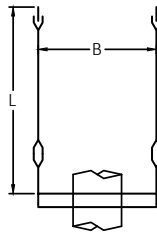

HR4

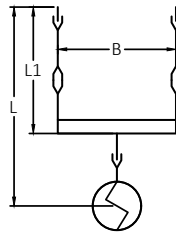

HR5

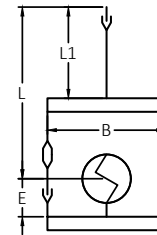

HR6

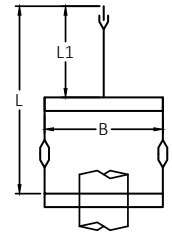

SPRING HANGERS

HS1

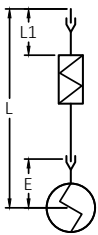

HS2

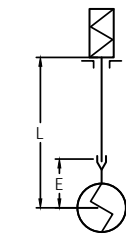

HS3

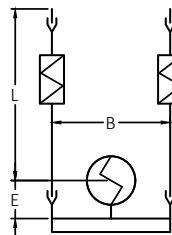

HS4

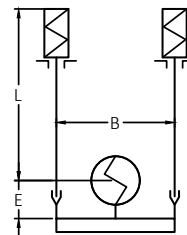

HS5

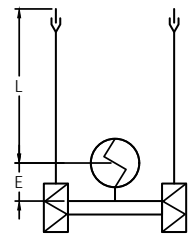

HS6

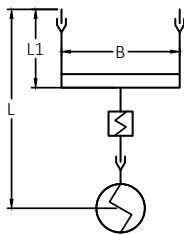

HS7

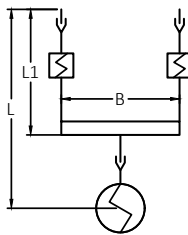

HS8

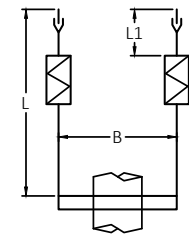

HS9

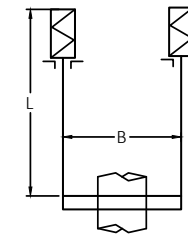

HS10

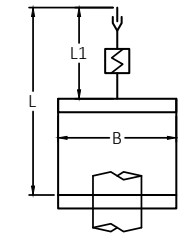

PIPE ATTACHMENT ELEMENTS

TYP N



TYP C



TYP R

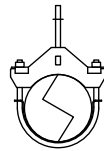

TYP W

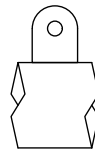

TYP B

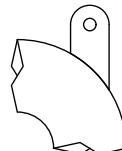

TYP V

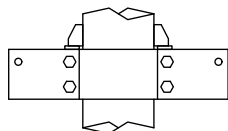

TYP X

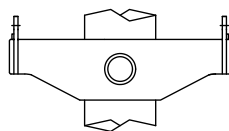

TYP D

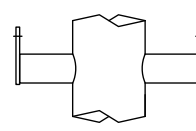

1

# SUPPORTS



## 1.1. USE

The supports are designed for the following types of pipe restraints:

Name	Symbol	Description, function	Types of supports
Sliding support	SS	Transfer of a vertical load and prevention of vertical downward movement by means of a pipe shoe under placed horizontal piping or two brackets for vertical piping. It allows horizontal movement. Frictional forces act in directions of the pipe movement.	21, 22, 23, 24, 25
Sliding support with a guide	SL	Pipe shoe with limited lateral movement and specified gap of min. +/-2 mm. Friction forces act in the pipe axis and in the direction of the pipe movement.	22, 23, 24, 25, 27
Sliding support with lift-off restraint	SLU	Pipe shoe that restrains lateral movement and lift-off with a specified gap of min. +/-2 mm. Friction forces act in the pipe axis and in the direction of the pipe movement.	22, 25
Sliding support with axial stop	SA	Pipe shoe with limited axial movement and a specified gap of min. +/-2 mm. Friction forces act in the pipe axis and in the direction of the pipe movement.	22, 25
Stop	SR	A device that limits pipe movement in all directions. A moment-free anchor.	26*
Anchor	FP	Movement and rotation limited in all directions, transfer of all force and moment components.	26

\* support not welded to auxiliary structure

## 1.2. PIPE ATTACHMENT ELEMENTS

In terms of pipe attachment elements, there are two types of supports:

- Clamped (C)
- Welding (W)

The following principles apply to the selection of pipe attachment elements:

1. Crevice corrosion occurs in the gap between a pipe clamp and pipe wall. Therefore, it is advisable to use welding supports in aggressive environments;
2. Clamped connection allows the pipe support to be relocated to its desired position multiple times;
3. If guided supports or anchors are used it must be taken into consideration that the friction connection between the clamp and the pipe does not prevent the possibility of accidental axial or rotational slipping. Therefore, if there is a principal requirement for reliability against slipping, it is advisable that welding design of these pipe supports is used;
4. Welding supports are not suitable for piping with high working temperatures (above 350 °C), because of the risk of cracking due to cyclic stresses caused by temperature gradients.

## 1.3. SLIDE SURFACES

Base supports (pipe shoes) can be used separately, they can be placed on embedded support plates or beams of an auxiliary structure, or they can be placed on slide plates (simple slide plates or guided slide plates). Base supports can also be used with spring support or with trapezes of double-rod hangers. The friction coefficient depends on the type of sliding surface.

### Important!

The sliding surfaces shall have a large enough area to allow for 25 mm reserve of movement in each direction in all operating conditions. This applies especially for supports with PTFE sliding surfaces.

The type and size of clamped pipe shoes must be selected in such a way that the piping does not slip in the clamp during pipe movement or support tilting is prevented when lateral load is applied.

Supports types distinguished according to sliding surfaces:

Description	Type of support sliding surface	Type of slide plate surface	Friction coefficient f
Support without slide plate	S	-	0,3 – 0,5*
Support with plain steel slide plate	S	S	0,3*
Support with polished stainless-steel sliding surface (mirror), slide plate with PTFE sliding surface	M	T	0,05 – 0,08
Slide plate with polished stainless-steel sliding surface, support with PTFE slide plate	T	M	0,05 – 0,08
Support with polished stainless-steel sliding surface, slide plate with bronze-graphite sliding surface	M	B	0,07 – 0,1
Slide plate with polished stainless-steel sliding surface, support with bronze graphite sliding surface	B	M	0,07 – 0,1

\* the friction coefficient depends on the type of paint; the static friction coefficient may be even higher if one of the sliding surfaces is painted!

1.4. SUPPORT DESIGN

According to the design of the support base the supports are distinguished:

Description	Type	Use
Light supports with one pipe clamp or one weld	21, 23	Low loads, small movements
Supports with two clamps or two welds	22, 24, 25	Larger movements
Supports with T-section base	21, 22	Low loads, economical
Supports with U-section base	22, 23	Low height
Supports with plate base	25, 26, 27	Higher loads
Supports with base made of 2 vertical channels	SF	High loads

Supports for high temperature applications (when creep-range temperatures apply) are designed for a service life of 200 000 hours. If a service life other than this is required, it is acceptable, upon consultation with the support manufacturer, to adapt

allowable support loads. In terms of cyclic fatigue, the clamps are designed for 1 500 full operation cycles (full relief - full load of  $F_p$ ) and 8 000 partial cycles with an amplitude of  $1.25 \times F_p$ . The OD given in the dimension tables are nominal values of external pipe diameter.

1.5. SUPPORT HEIGHT

Supports can either have a fixed height or their height can be adjusted as required (supports with adjustable height). Low supports (type 21, 23, 24) are preferred for non-insulated pipes. For insulated pipes, it is preferable to select supports with a standard height,

which corresponds to the height of the anchor support (type 26). The supports of types 22 and 25 can be specified in a height-adjustable design to allow site adjustment in the range of approximately +/- 0.1 times the nominal support height.

Overview of support types according to construction height:

Type	Version	Use
21	Type 21-1, -3	Standard and optional support height
	Type 21-2, -4	Low support, only one height for a given pipe size
22	Type 22-1, -3	Standard and optional support height
	Type 22-2, -4	Low support, only one height for a given pipe size
23	-	Low support, only one height for a given pipe size
24	-	Low support, only one height for a given pipe size
25	Type 25-1	Standard and optional support height
	All	
	Type 25-3	
	Type 25-4	
26	Type 26-1	Standard support height, only one height for a given pipe size
	Type 26-2	Standard and optional support height
27	-	Standard support height, only one height for a given pipe size
28	-	Standard support height, only one height for a given pipe size

Overview of support types, according to support height (mm):

DN	OD	21-1, -3 22-1, -3	21-2, -4	22-2, -4	23-1	23-2, 24-1	25-1..5	25-6	26-1, 27	26-2
15	21,3	100	51	57	-	-	-	-	-	-
20	26,9	100	54	60	-	-	-	-	-	-
25	31,8	100	66	72	-	-	-	-	-	-
25	33,7	100	67	73	-	-	-	-	-	-
32	38	120	69	75	-	-	-	-	-	-
32	42,4	120	72	78	-	-	-	-	-	-
40	48,3	120	75	81	-	-	-	-	-	-
50	57	155	89	96	63	74	155	179	155	179
50	60,3	155	91	98	66	76	155	180	155	180
65	73	165	97	104	77	85	165	207	165	207
65	76,1	165	99	106	79	87	165	208	165	208
80	88,9	170	125	132	87	94	170	214	170	214
100	108	200	134	143	101	111	200	234	200	234
100	114,3	200	138	147	105	115	200	237	200	237
125	127	220	164	173	113	123	220	264	220	264
125	133	220	167	176	117	126	220	267	220	267
125	139,7	220	170	179	121	130	220	270	220	270
125	141,3	220	171	180	122	131	220	271	220	271
150	159	240	180	189	118	129	240	280	240	280
150	168,3	240	185	194	125	135	240	284	240	284
175	193,7	-	-	-	141	150	270	317	270	317
200	219,1	-	-	-	156	165	290	330	290	330
225	244,5	-	-	-	170	179	300	342	300	342
250	273	-	-	-	196	205	330	377	330	377
300	323,9	-	-	-	225	234	380	422	380	422
350	355,6	-	-	-	243	251	400	448	400	448
350	377	-	-	-	254	263	400	459	400	459
400	406,4	-	-	-	278	290	430	473	430	473
400	426	-	-	-	290	301	430	483	430	483
450	457	-	-	-	307	318	470	529	470	529
500	508	-	-	-	312	324	500	554	500	554
500	530	-	-	-	325	337	500	565	500	565
550	559	-	-	-	342	359	530	600	530	600
600	609,6	-	-	-	376	394	560	625	560	625
600	630	-	-	-	388	406	560	635	560	635
650	660	-	-	-	406	423	590	650	590	650
700	711	-	-	-	410	428	630	696	630	696
700	720	-	-	-	416	434	630	700	630	700
750	762	-	-	-	441	459	670	721	670	721
800	813	-	-	-	471	488	700	757	700	757
800	820	-	-	-	475	492	700	760	700	760

1.6. SUPPORT LENGTH AND WIDTH

Sliding supports, guides or other restraints have a base plate through which the piping load is transferred to the support structure (steel or concrete). The contact surface may consist of a beam flange, slide or base plate, spring support or another structural element. Under all operating conditions, the restraint must be functional, i.e. it must transfer the required force or moment components and allow, or limit required movements.

The support length limits axial movements, the support width limits lateral movements. Moreover, the support width also limits the height of the support because it is one of the variables that affects the support tilting. This is manifested by slipping of the support clamps around the pipe axis and, as a result, the support web is no longer oriented perpendicularly to the support surface.

The area of the support structure (e.g. beam, embedded plate, slide plater etc.) that is in contact with the support base does not necessarily have to be larger than the support base, because the increase in size of the slide plate is not always proportional to the increase in the movement reserve. In most cases, it is desirable that the support base overlaps the contact surface of the beam or a (embedded) sliding plate - it helps reduce contamination and corrosion of the sliding surfaces. The use of a slide plate with a length of more than twice the width of the beam flange, that the support sits on, may overload the supporting structure and cause torsional loads on structure beams. When selecting a support type, the dimensions of contact surface of both the pipe support base and the supporting structure shall always be considered and evaluated.

Maximum movements and reserves:

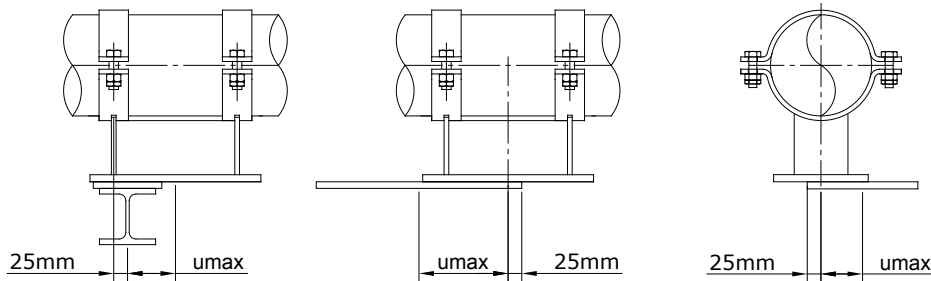

Standard supports (both welded and clamped) are designed in the following lengths:

- Short (type 21, 23)
- Standard lengths (other types)
- Extended (types 24 and 25)

The length of the support shall be selected so that a travel reserve in the axial pipe direction of minimum 25 mm is maintained.

Overview of support lengths:

DN	Typ 21	Typ 22	Typ 23	Typ 24	Typ 25	Typ 26–28	Typ 29
mm	mm	mm	mm	mm	mm	mm	mm
15–40	90	150	-	-	-	-	-
50–80	120	200	80	180	200	260	260
100–200	150	240	100	220	240	320	320
225–350	-	-	120	260	300	400	400
400–450	-	-	140	300	350	460	460
500	-	-	140	300	350	480	480
550–800	-	-	180	380	450	600	600



### 1.7. INSULATION THICKNESS

When selecting the type of support, it is necessary to consider whether it is compatible with the required insulation thickness. The height of the support shall be selected so that the support base is at least 30 mm outside of the insulation. The maximum insulation thickness for each support type can be calculated from the dimension Hb given in the dimension tables.

Minimum insulation thicknesses  $t_{i\min}$  to cover the clamp ends:

DN (mm)	15-40	50-80	100-200	225-350	400-500	550-800
$t_{i\min}$ (mm)	35	40	60	70	85	120

### 1.8. DESIGN LOAD AND DESIGN TEMPERATURE

The design load of supports for permanent loads is specified, according to formula:  $F_d^T = 1,0 \times F_a^T$ , where the index  $T$  expresses the temperature combinations of analyzed operating conditions, acting simultaneously with the load.  $F_a$  is the required restraint load obtained from the piping stress analysis. Only the vertical load component is considered for pipe shoes, frictional forces are

included in the table of permissible support load  $F_p$ . For guided pipe shoes, axial stops and anchors, all force components in the directions of limited movement are considered.

The design temperature  $T_d$  is equal to the maximum allowable temperature of the piping without allowances.

### 1.9. LOAD-BEARING CAPACITY OF SUPPORTS

The permissible support loads  $F_p$  are calculated for compression loads in the direction of the support pipe shoe, considering the effect of friction of  $0.3 \times F_p$ . The load-bearing capacity decreases for higher values of the sliding friction coefficient and increases for its lower values. For guided pipe shoes, axial stops and anchors, the load-bearing capacity of the components must be calculated according to formulas given for each type.

The values of the permissible loads  $F_p$ , stated in the tables of the data sheets, have been worked out for the basic design temperature of 80 °C and for the support material of the material group (MS) 1 and the load category G. The load-bearing capacity at higher temperatures and for other materials is evaluated using the following formulas:  $F_{pt,M} = k_{t,M} \times F_p$ , where the correction factor  $k_{t,M}$  is listed in the table below or in tables for each type of support.

Table 1.1 - Correction factors  $k_{t,M}$  for supports:

Material Group/T	80	100	150	200	250	300	350	400	450	480	490	500	510	520	530	540	550	560	570	580	600	
1	1,00	0,94	0,89	0,84	0,76	0,62	0,55															
2	1,25	1,22	1,20	1,14	1,06	0,97	0,88	0,80	0,72	0,67	0,65	0,57	0,46	0,37	0,30	0,24						
3									0,90	0,83	0,74	0,65	0,57	0,49	0,43	0,37	0,31	0,27	0,23	0,20		
4	1,06	1,02	0,96	0,89	0,82	0,77	0,73	0,71	0,69													
5	1,04	1,00	0,93	0,89	0,88	0,85	0,85	0,85	0,84	0,84	0,83	0,82										
6									0,69	0,68	0,67	0,67	0,66	0,66	0,65	0,65	0,64	0,62	0,57	0,52	0,42	
7	1,11	1,11	1,11	1,06	0,97	0,89	0,81	0,75	0,71													

For occasional loads of category Q, the conversion shall be as follows:  $F_{p,Q} = 1,2 \times F_{p,G}$ .

### 1.10. INSULATION THICKNESS

The following factors shall be considered when specifying the support surface finish:

- Support design – welding or clamped;
- Welding supports shall be specified with a suitable shop primer that is compatible with the assembly topcoat;
- Corrosive aggressiveness of the environment and required service life of surface finish;
- Temperature effect;
- Effect of surface finish on the sliding surface.

Clamped supports made of carbon steel (material groups 1, 2 and 7) are supplied with a primer or topcoat as a standard. A requirement for galvanizing or hot-dip galvanizing of supports of material group 1 for temperatures up to 200 °C shall be specified in the order.

Welding supports made of carbon steel are supplied with a primer or topcoat as a standard.

Supports made of alloy steel (material group 3) are supplied with a primer.

Stainless steel supports (material groups 4, 5, 6) are supplied without a surface finish.

1.11. SURFACE FINISH OF SLIDING SURFACES

It is important to consider that the friction coefficient of sliding supports is largely affected by the surface finish of the sliding surfaces that are in contact with each other. If both the support base and the slide plate are painted with a topcoat or coats with NDFT > 100 um, the surfaces may stick together and increase the

assumed friction coefficient above the value of 0.3. If the top layers of the coating break off, the corrosion protection will be damaged as well. The corrosion protection can also get damaged when sliding surfaces are galvanized.

Des.	Description of surfaces in contact	Friction coefficient	Design
S	<p><b>Steel - steel, coated</b></p> <p>The bottom surface of the support base and the surface of the structure or slide plate, over which the support slides, are painted. The support movement results in the coating being rubbed off. The paint also acts as an adhesive and increases friction. Use of this type of sliding surfaces is intended mainly for dry indoor environment. As both sliding surfaces are provided with a primer only, it is assumed that slight corrosion might occur.</p>	0,2–0,5	All supports of the slide surface S design are placed directly on the supporting structure or slide plate of the S design.
M	<p><b>Support with mirror - slide plate with PTFE</b></p> <p>The bottom surface of the support base is completely made of polished stainless steel, which slides over a circular PTFE plate that is attached to the slide plate. The support base must always overlap the PTFE slide plate with a 25 mm reserve. The use is limited to pipe temperature up to 450 °C. No additional surface finish may be applied.</p>	0,2–0,5	All supports of the slide surface M design are placed directly on the supporting structure or slide plate of the T design.
T	<p><b>Support with PTFE - slide plate with mirror surface</b></p> <p>A circular PTFE plate is attached to the bottom surface of the support base and the entire surface of the slide plate is made of polished stainless steel. The slide plate mirror must always overlap the PTFE slide plate with a 25 mm reserve. The use is limited to pipe temperature up to 450 °C. No additional surface finish may be applied.</p>	0,05–0,1	All supports of the slide surface T design are placed on the slide plate of the M design.
B	<p><b>Support with mirror surface - slide plate with bronze-graphite</b></p> <p>The bottom surface of the support base is completely made of polished stainless steel, which slides over a bronze surface (round, square) with graphite nests, fixed to the slide plate. The support base must always overlap the bronze plate with a 25 mm reserve. The use is limited to pipe temperature up to 550 °C. No additional surface finish may be applied.</p>	0,05–0,1	All supports in slide surface M design are placed on the slide plate of the B design.

Marking of sliding surfaces in the type number: the last character in the support designation S, M, or T.

Design of sliding surfaces M and T:

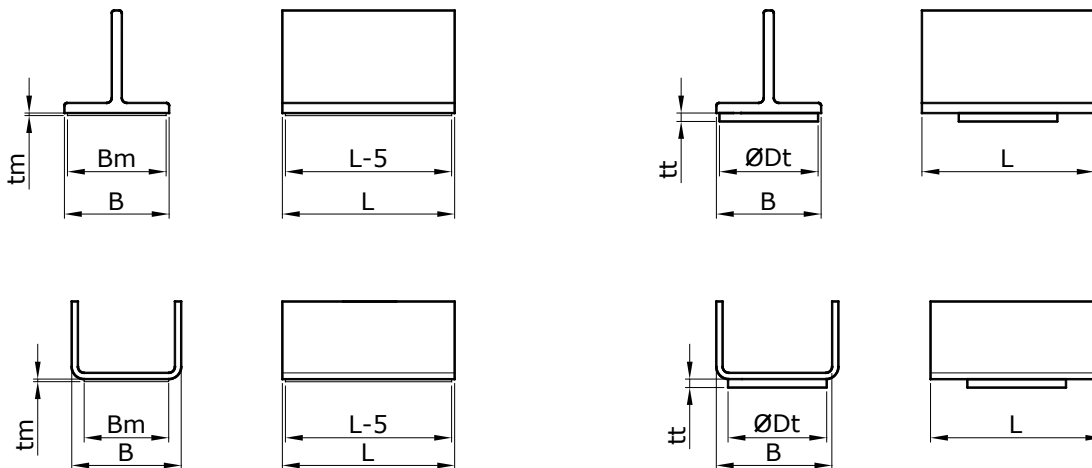

M surface - stainless steel mirror

T surface - round PTFE plate

### 1.12. STOPS, GUIDES AND ANCHORS

The supports can be supplemented with elements that limit the pipe movement in one or both horizontal directions. Basic configurations are listed below:

#### a) Guided pipe shoes

They limit the horizontal movement of the support in the direction perpendicular to pipe axis (lateral direction). Guided pipe shoes in their welding version are used to restrain both permanent (generated by gravity and restrained thermal expansion) and occasional loads. Clamped supports are normally used to stabilize pipe position against occasional events – e.g. under a wind load or movements due to the uncertainty of the frictional forces on a flexible pipe. The reason for this is the limited load-bearing capacity of the clamp-pipe friction joint under a torsional load, when the force acting on the moment arm (with the height of the support  $H$ ) may cause the joint to twist and thus cause the support tilting.

Permissible support lateral forces are listed in the data sheets. For higher loads, multiple guided pipe shoes of production group 3 shall be used.

The lowest lateral gap of this design is  $\pm 1$  mm. The maximum gap when L-section stops are used is not limited. When lift-off restraints are used the maximum gap is limited to approximately  $\pm 10$  mm. For more details, please refer to the data sheet of slide plates.

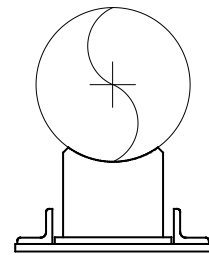

Welding support guides

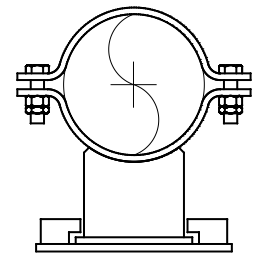

Clamp support guides

#### b) Axial stops

They limit the horizontal movement of the support in the direction of pipe axis (axial direction). Pipe shoes with axial stops in their welding version are used to restrain both permanent (generated by gravity and restrained thermal expansion) and occasional loads. Clamped pipe shoes are normally used to stabilize pipe position against accidental events – e.g. under a wind load or movements due to the uncertainty of the frictional forces on a flexible pipe. The reason for this is the limited load-bearing capacity of the clamp-pipe friction joint under a torsional load. This can be prevented by welding two flat shear lugs to the lower surface of the pipe, on each side of the support. The lugs must be welded right next to the clamps without a gap.

Axial stops may be provided, either, by limiting the support base by an element attached to the slide plate, or by a stop welded to the support base that rests on a steel structure beam under the support.

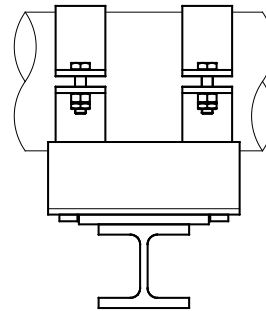

Stop on slide plate

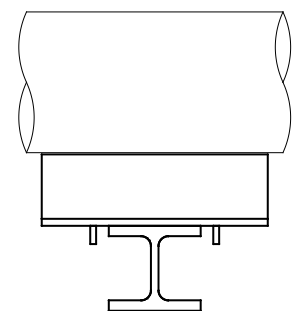

Stop on support base

#### c) Anchors

Anchor is a restraint that limits all movements and partly rotation as well. An anchor is realized by welding or bolting a support to steel structure or (embedded) base plate. To absorb primary loads in the pipe axis (axial force and torque), it is recommended to weld shear lugs on the pipe.

#### d) Vertical pipes

Guided pipe shoes can also be used with vertical pipes as a stabilizing support element. For  $DN > 300$  it is recommended to secure the support against slipping in the axial direction by welding a shear lug on the pipe..

#### e) Guides and stops for pipe racks

For guided pipe shoes for which a higher permissible lateral load is required, either a guide with multiple pipe shoes of production group 3 or a guide of type 27 may be used. The guides with multiple pipe shoes require free space next to the pipe to accommodate a beam on each side of the pipe that would absorb lateral forces. In places where, for example, there are several pipes with small spacing at one elevation and there is no space for beams between pipes, guided pipe shoes of type 27 or pipe shoes with axial stop of type 28 shall be used. When using supports of these types it is always necessary to weld a shear lug to the pipe to secure the support against slipping.

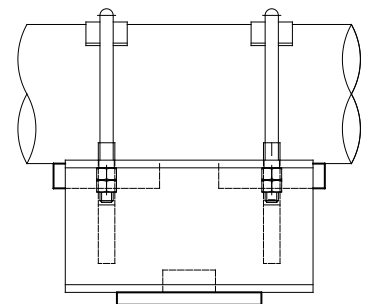
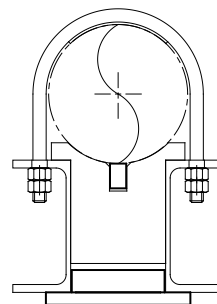

21-3

Short support of standard and optional height. Support height H can be specified in the interval 0.5 × H to 1 × H.

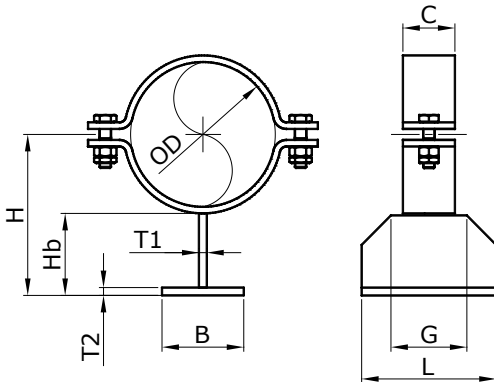

DESIGNATION

21-3 MS-DNK-H-KP

Example of designation: 21-34-073-170

- DNK – pipe outer diameter code
- H – required support height
- MS – material group code
- KP – sliding surface code

ASSEMBLY

The clamp bolts are to be hand-tightened until the clamp is in full contact with the pipe and then the bolts to be tightened by 180° using a wrench.

DIMENSIONS AND PARAMETERS

OD	DNK	H	B	C	L	Hb	T1	T2	G	Fp	m
mm	mm	mm	mm	mm	mm	mm	mm	mm	mm	kN	kg
21,3	015	100	40	30	100	82	6	6	80	1,1	0,88
26,9	020	100	40	30	100	79	6	6	80	1,1	0,89
31,8	025	100	40	30	100	77	6	6	80	1,2	0,90
33,7	025	100	40	30	100	76	6	6	80	1,2	0,90
38	038	120	40	30	100	94	6	6	80	1,0	1,05
42,4	032	120	40	30	100	91	6	6	80	1,0	1,05
48,3	040	120	40	30	100	88	6	6	80	1,0	1,05
57	057	155	50	40	150	117	8	8	100	1,9	2,2
60,3	050	155	50	40	150	115	8	8	100	1,9	2,2
73	073	165	50	40	150	119	8	8	100	1,8	2,3
76,1	065	165	50	40	150	117	8	8	100	1,8	2,4
88,9	080	170	50	40	150	116	8	8	100	1,8	2,4
108	108	200	60	50	200	135	10	10	130	2,5	4,2
114,3	100	200	60	50	200	131	10	10	130	2,5	4,2
127	127	220	80	50	200	145	10	10	130	2,4	4,7
133	133	220	80	50	200	142	10	10	130	2,4	4,7
139,7	125	220	80	50	200	139	10	10	130	2,4	4,8
141,3	141	220	80	50	200	138	10	10	130	2,4	4,8
159	159	240	80	50	200	149	10	10	130	2,3	5,1
168,3	150	240	80	50	200	144	10	10	130	2,3	5,1

MATERIAL GROUPS

MS No.	1	2	3	4	5	6	7
Tmax (°C)	350	500	580	400	500	620	350
Material	S235JR	16Mo3	10CrMo910	1.4301	1.4571	1.4948	P275NH

PERMISSIBLE LOADS

Resultant external force must satisfy the following equation for total load  $1,5 \times F_x/F_p + 3,0 \times F_y/F_p + F_z/F_p \leq 1$ , where  $F_x$  is a force in the direction of pipe axis and  $F_y$  is a horizontal force perpendicular to the pipe axis. The  $F_x$  and  $F_y$  components do not include the friction forces generated by vertical component  $F_z$ . The load-bearing capacity at higher temperatures and for different materials shall satisfy the following equation:  $F_{pt,M}^G = k_{t,M} \times F_p$  where the correction factor is specified according to table 1.1.

DESIGN VERSIONS

- Sliding surfaces (KP):
- S – steel
- T – PTFE plate with a diameter  $Dt = B - 5$  mm (see 2.10)

## 21-4

Short, low support. Support height H cannot be changed.

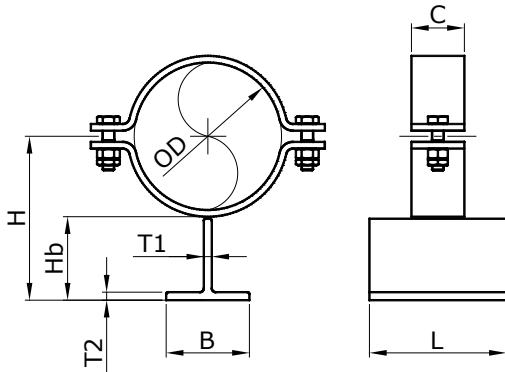

### DESIGNATION

#### 21-4 MS-DNK-H-KP

Example of designation: 21-41-100-170

DNK – pipe outer diameter code

H – required support height

MS – material group code

KP – sliding surface code

### ASSEMBLY

The clamp bolts are to be hand-tightened until the clamp is in full contact with the pipe and then the bolts to be tightened by 180° using a wrench.

### DIMENSIONS AND PARAMETERS

OD	DNK	H	B	C	L	Hb	T1	T2	Fp	m
mm	mm	mm	mm	mm	mm	mm	mm	mm	kN	kg
21,3	015	56	40	30	100	40	5	5	1,0	0,55
26,9	020	59	40	30	100	40	5	5	1,1	0,57
31,8	025	71	50	30	100	50	6	6	1,1	0,74
33,7	025	72	50	30	100	50	6	6	1,0	0,74
38	038	74	50	30	100	50	6	6	0,9	0,76
42,4	032	77	50	30	100	50	6	6	0,9	0,78
48,3	040	80	50	30	100	50	6	6	1,0	0,80
57	057	95	60	40	120	60	7	7	1,8	1,41
60,3	050	97	60	40	120	60	7	7	1,8	1,43
73	073	103	60	40	120	60	7	7	1,8	1,51
76,1	065	105	60	40	120	60	7	7	1,8	1,53
88,9	080	131	80	40	120	80	9	9	1,8	2,1
108	108	142	80	50	150	80	9	9	2,5	3,0
114,3	100	146	80	50	150	80	9	9	2,5	3,1
127	127	172	100	50	150	100	11	11	2,4	4,0
133	133	175	100	50	150	100	11	11	2,4	4,1
139,7	125	178	100	50	150	100	11	11	2,4	4,1
141,3	141	179	100	50	150	100	11	11	2,4	4,2
159	159	188	100	50	150	100	11	11	2,3	4,3
168,3	150	193	100	50	150	100	11	11	2,3	4,4

### MATERIAL GROUPS

MS No.	1	4	7
Tmax (°C)	350	400	350
Material	S235JR	1.4301	S235J2

### PERMISSIBLE LOADS

Resultant external force must satisfy the following equation for total load:  $1.5 \times F_x/F_p + 3.0 \times F_y/F_p + F_z/F_p \leq 1$ , where  $F_x$  is a force in the direction of pipe axis and  $F_y$  is a horizontal force perpendicular to the pipe axis. The  $F_x$  and  $F_y$  components do not include the friction forces generated by vertical component  $F_z$ . The load-bearing capacity at higher temperatures and for different materials shall satisfy the following equation:  $F_{pt,M}^G = k_{t,M} \times F_p$  where the correction factor is specified according to table 1.1.

### DESIGN VERSIONS

Sliding surfaces (KP):

S – steel

22-3

Support with standard or optional height. Support height H can be specified in the interval  $0.5 \times H$  to  $1 \times H$ . Also available in long version.

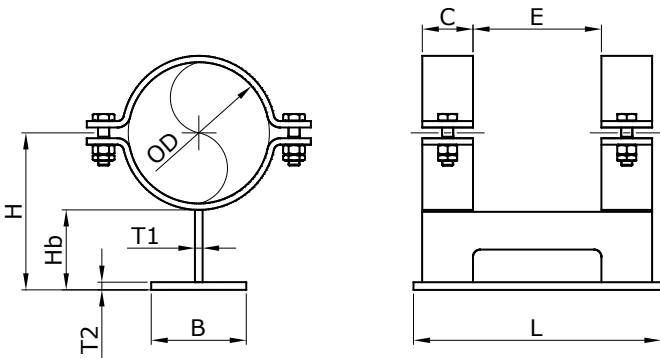

DESIGNATION

22-3(L) MS-DNK-H-KP

Example of designation: 22-3L2-108-220-M

- DNK – pipe outer diameter code
- H – required support height
- MS – material group code
- KP – sliding surface code
- L – long version, the character is not normally specified

ASSEMBLY

The clamp bolts are to be hand-tightened until the clamp is in full contact with the pipe and then the bolts to be tightened by 180° using a wrench.

DIMENSIONS AND PARAMETERS

OD	DNK	H	B	L	Hb	E	C	T1	T2	Fp	m
mm	mm	mm	mm	mm	mm	mm	mm	mm	mm	kN	kg
21,3	015	100	50	150	83	80	30	6	6	2,5	1,45
26,9	020	100	50	100	80	80	30	6	6	2,5	1,47
31,8	025	100	50	100	78	80	30	6	6	2,6	1,50
33,7	025	100	50	100	77	80	30	6	6	2,6	1,50
38	038	120	60	100	95	80	30	6	6	2,2	1,73
42,4	032	120	60	100	92	80	30	6	6	2,2	1,74
48,3	040	120	60	100	89	80	30	6	6	2,3	1,76
57	057	155	80	150	119	110	40	8	8	4,2	3,8
60,3	050	155	80	150	117	110	40	8	8	4,2	3,8
73	073	165	90	150	121	110	40	8	8	4,1	4,2
76,1	065	165	90	150	119	110	40	8	8	4,1	4,2
88,9	080	170	90	150	118	110	40	8	8	4,2	4,3
108	108	200	100	200	137	140	50	10	10	5,7	7,4
114,3	100	200	100	200	133	140	50	10	10	5,7	7,5
127	127	220	120	200	147	140	50	10	10	5,5	8,4
133	133	220	120	200	144	140	50	10	10	5,5	8,5
139,7	125	220	120	200	141	140	50	10	10	5,5	8,5
141,3	141	220	120	200	140	140	50	10	10	5,5	8,6
159	159	240	120	200	151	140	50	10	10	5,3	9,1
168,3	150	240	120	200	146	140	50	10	10	5,3	9,2

MATERIAL GROUPS

MS No.	1	2	3	4	5	6	7
Tmax (°C)	350	500	580	400	500	620	350
Material	S235JR	16Mo3	10CrMo910	1.4301	1.4571	1.4948	P275NH

PERMISSIBLE LOADS

Resultant external force must satisfy the following equation for total load:  $1.5 \times F_x/F_p + 3.0 \times F_y/F_p + F_z/F_p \leq 1$ , where  $F_x$  is a force in the direction of pipe axis and  $F_y$  is a horizontal force perpendicular to the pipe axis. The  $F_x$  and  $F_y$  components do not include the friction forces generated by vertical component  $F_z$ . The load-bearing capacity at higher temperatures and for different materials shall satisfy the following equation:  $F_{pt,M}^G = k_{t,M} \times F_{pr}$ , where the correction factor is specified according to table 1.1.

DESIGN VERSIONS

- Sliding surfaces (KP):
- S – steel
- T – PTFE plate with a diameter  $D_t = B - 5$  mm (see 2.10)

Long version – the support length is 1.5 times longer than the standard length L. Other dimensions remain unchanged; the weight is 1.5 times the tabular value of m.

## 22-4

Low support. Support height H cannot be changed. Also available in long version.

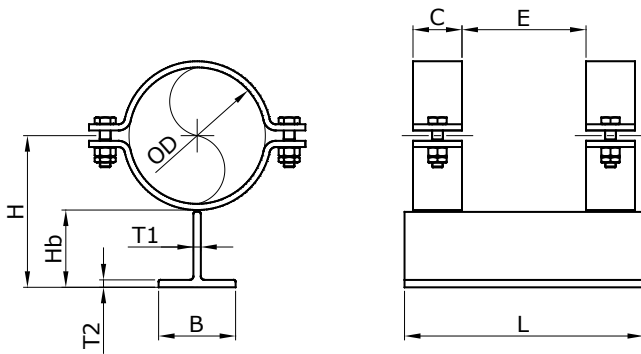

### DESIGNATION

#### 22-3(L) MS-DNK-H-KP

Example of designation: 22-41-108-220

DNK – pipe outer diameter code

H – support height

MS – material group code

KP – sliding surface code

L – long version, the character is not normally specified

### ASSEMBLY

The clamp bolts are to be hand-tightened until the clamp is in full contact with the pipe and then the bolts to be tightened by 180° using a wrench.

### DIMENSIONS AND PARAMETERS

OD	DNK	H	B	L	Hb	E	C	T1	T2	Fp	m
mm	mm	mm	mm	mm	mm	mm	mm	mm	mm	kN	kg
21,3	015	56	40	150	83	80	30	6	6	4,0	1,38
26,9	020	59	40	150	80	80	30	6	6	3,8	1,40
31,8	025	71	50	150	78	80	30	6	6	3,7	1,43
33,7	025	72	50	150	77	80	30	6	6	3,7	1,43
38	038	74	50	150	95	80	30	6	6	3,7	1,58
42,4	032	77	50	150	92	80	30	6	6	3,7	1,60
48,3	040	80	50	150	89	80	30	6	6	3,7	1,62
57	057	95	60	200	119	110	40	8	8	6,5	3,5
60,3	050	97	60	200	117	110	40	8	8	6,5	3,5
73	073	103	60	200	121	110	40	8	8	6,5	3,7
76,1	065	105	60	200	119	110	40	8	8	6,5	3,7
88,9	080	131	80	200	118	110	40	8	8	6,3	3,8
108	108	142	80	250	137	140	50	10	10	7,9	6,7
114,3	100	146	80	250	133	140	50	10	10	7,9	6,7
127	127	172	100	250	147	140	50	10	10	7,8	7,6
133	133	175	100	250	144	140	50	10	10	7,8	7,7
139,7	125	178	100	250	141	140	50	10	10	7,8	7,7
141,3	141	179	100	250	140	140	50	10	10	7,8	7,8
159	159	188	100	250	151	140	50	10	10	7,8	8,3
168,3	150	193	100	250	146	140	50	10	10	7,8	8,4

### MATERIAL GROUPS

MS No.	1	4	7
Tmax (°C)	350	400	350
Material	S235JR	1.4301	S235J2

### PERMISSIBLE LOADS

Resultant external force must satisfy the following equation for total load:  $1.5 \times F_x/F_p + 3.0 \times F_y/F_p + F_z/F_p \leq 1$ , where  $F_x$  is a force in the direction of pipe axis and  $F_y$  is a horizontal force perpendicular to the pipe axis. The  $F_x$  and  $F_y$  components do not include the friction forces generated by vertical component  $F_z$ . The load-bearing capacity at higher temperatures and for different materials shall satisfy the following equation:  $F_{pt,M}^G = k_{t,M} \times F_p$  where the correction factor is specified according to table 1.1.

### DESIGN VERSIONS

Sliding surfaces (KP):

S – steel

Long version – the support length is 1.5 times longer than the standard length L. Other dimensions remain unchanged; the weight is 1.5 times the tabular value of m.

22-6

Standard adjustable support. Support height can be adjusted in the range of  $H_{min}$  to  $H_{max}$ . Also available in long version.

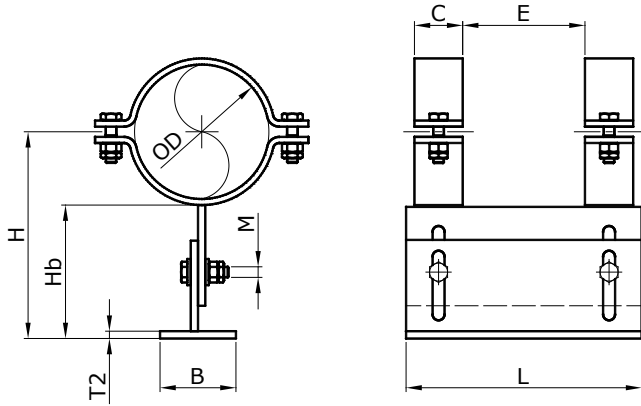

DESIGNATION

22-6(L) MS-DNK-H-KP

Example of designation: 22-63-025-112

- DNK – pipe outer diameter code
- H – required support height
- MS – material group code
- KP – sliding surface code
- L – long version, the character is not normally specified

ASSEMBLY

The clamp bolts are to be hand-tightened until the clamp is in full contact with the pipe and then the bolts to be tightened by 180° using a wrench.

Tightening torque for height adjustment connection bolts: M8-20 Nm, M10-40 Nm, M12-75 Nm.

DIMENSIONS AND PARAMETERS

OD	DNK	H	Hmin	Hmax	B	L	Hb	E	C	T2	M	Fp	m
mm	mm	mm	mm	mm	mm	mm	mm	mm	mm	mm	mm	kN	kg
21,3	015	100	71	112	50	150	83	80	30	6	8	2,5	1,66
26,9	020	100	71	112	50	100	80	80	30	6	8	2,5	1,69
31,8	025	100	71	112	50	100	78	80	30	6	8	2,6	1,72
33,7	025	100	71	112	50	100	77	80	30	6	8	2,6	1,72
38	038	120	91	132	60	100	95	80	30	6	8	2,2	1,98
42,4	032	120	91	132	60	100	92	80	30	6	8	2,2	2,0
48,3	040	120	95	130	60	100	89	80	30	6	10	2,3	2,0
57	057	155	110	175	80	150	119	110	40	8	10	4,2	4,4
60,3	050	155	110	175	80	150	117	110	40	8	10	4,2	4,4
73	073	165	120	185	90	150	121	110	40	8	10	4,1	4,8
76,1	065	165	120	185	90	150	119	110	40	8	10	4,1	4,8
88,9	080	170	129	188	90	150	118	110	40	8	12	4,2	5,0
108	108	200	149	223	100	200	137	140	50	10	12	5,7	8,6
114,3	100	200	149	223	100	200	133	140	50	10	12	5,7	8,6
127	127	220	169	243	120	200	147	140	50	10	12	5,5	9,7
133	133	220	169	243	120	200	144	140	50	10	12	5,5	9,7
139,7	125	220	169	243	120	200	141	140	50	10	12	5,5	9,8
141,3	141	220	169	243	120	200	140	140	50	10	12	5,5	9,8
159	159	240	189	263	120	200	151	140	50	10	12	5,3	10,5
168,3	150	240	189	263	120	200	146	140	50	10	12	5,3	10,6

MATERIAL GROUPS

MS No.	1	2	3	4	5	6	7
Tmax (°C)	350	500	580	400	500	620	350
Material	S235JR	16Mo3	10CrMo910	1.4301	1.4571	1.4948	P275NH

PERMISSIBLE LOADS

Resultant external force must satisfy the following equation for total load:  $1.5 \times F_x/F_p + 3.0 \times F_y/F_p + F_z/F_p \leq 1$ , where  $F_x$  is a force in the direction of pipe axis and  $F_y$  is a horizontal force perpendicular to the pipe axis. The  $F_x$  and  $F_y$  components do not include the friction forces generated by vertical component  $F_z$ . The load-bearing capacity at higher temperatures and for different materials shall satisfy the following equation:  $F_{pt,M}^G = k_{t,M} \times F_{pr}$ , where the correction factor is specified according to table 1.1

DESIGN VERSIONS

- Sliding surfaces (KP):
- S – steel
- T – PTFE plate with a diameter  $D_t = B - 5$  mm (see 2.10.)

Long version – the support length is 1.5 times longer than the standard length L. Other dimensions remain unchanged; the weight is 1.5 times the tabular length value of m.



## 23-2

Short and low support for uninsulated pipes. Support height H cannot be changed.

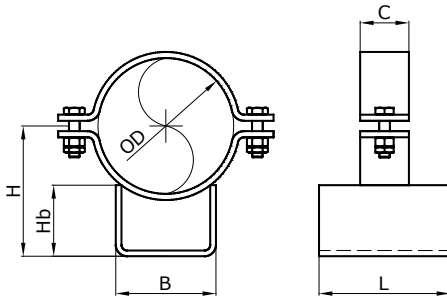

### DESIGNATION

#### 23-2 MS-DNK-KP

Example of designation: 23-21-450-T

DNK – pipe outer diameter code

MS – material group code

KP – sliding surface code

### ASSEMBLY

The clamp bolts are to be hand-tightened until the clamp is in full contact with the pipe and then the bolts to be tightened by 180° using a wrench.

### DIMENSIONS AND PARAMETERS

OD	DNK	H	B	L	Hb	C	Fp	m
mm	mm	mm	mm	mm	mm	mm	kN	kg
57	057	74	60	80	50	40	2,8	1,06
60,3	050	76	60	80	50	40	2,8	1,08
73	073	85	60	80	50	40	2,8	1,15
76,1	065	87	60	80	50	40	2,8	1,17
88,9	080	94	60	80	50	40	2,8	1,25
108	108	111	80	100	60	50	3,8	2,01
114,3	100	115	80	100	60	50	3,8	2,07
127	127	123	80	100	60	50	3,8	2,20
133	133	126	80	100	60	50	3,8	2,25
139,7	125	130	80	100	60	50	3,8	2,31
141,3	141	131	80	100	60	50	3,8	2,34
159	159	129	120	100	60	50	4,9	2,82
168,3	150	135	120	100	60	50	4,9	2,91
193,7	175	150	120	100	60	50	4,9	3,2
219,1	200	165	120	100	60	50	4,9	3,4
244,5	225	179	120	120	60	60	6,1	5,1
273	250	205	160	120	80	60	5,9	6,1
323,9	300	234	160	120	80	60	5,9	6,7
355,6	350	251	160	120	80	60	6,7	7,1
377	377	263	160	120	80	60	6,7	7,3
406,4	400	290	210	140	100	70	6,7	11,6
426	426	301	210	140	100	70	6,7	12,0
457	450	318	210	140	100	70	6,7	12,5
508	500	324	300	140	100	70	6,7	15,0
530	530	337	300	140	100	70	6,7	15,4
559	550	359	300	180	100	90	9,3	28,5
609,6	600	394	350	180	120	90	13,0	31,3
630	630	406	350	180	120	90	13,0	31,9
664	650	423	350	180	120	90	10,0	33,1
711,2	700	428	430	180	120	90	10,0	35,5
720	720	434	430	180	120	90	10,0	35,8
762	750	459	430	180	120	90	10,0	37,3
812,8	800	488	430	180	120	90	10,0	38,9
820	820	492	430	180	120	90	10,0	39,2

### MATERIAL GROUPS

MS No.	1	4
Tmax (°C)	350	400
Material	S235JR	1.4301

### DESIGN VERSIONS

Sliding surfaces (KP):

S – steel

M – stainless steel mirror

T – PTFE plate with diameter Dt = B - 5 mm (see 2.10.)

### PERMISSIBLE LOADS

Resultant external force must satisfy the following equation for total load:  $2.0 \times F_x/F_p + F_y/F_p + F_z/F_p \leq 1$ , where  $F_x$  is a force in the direction of pipe axis and  $F_y$  is a horizontal force perpendicular to the pipe axis. The  $F_x$  and  $F_y$  components do not include the friction forces generated by vertical component  $F_z$ . The load-bearing capacity at higher temperatures and for different materials shall satisfy the following equation:  $F_{pt,M}^G = k_{t,M} \times F_p$ , where the correction factor is specified according to table 1.1.

## 24-1

Short support for uninsulated pipes. Support height H cannot be changed.

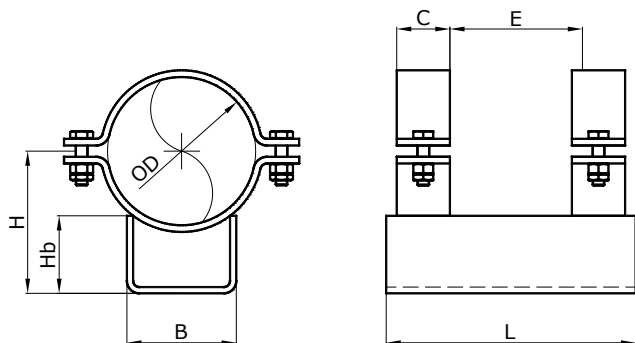

### DESIGNATION

#### 24-1 MS-DNK-KP

Example of designation: 24-11-377

DNK – pipe outer diameter code

MS – material group code

KP – sliding surface code

### ASSEMBLY

The clamp bolts are to be hand-tightened until the clamp is in full contact with the pipe and then the bolts to be tightened by 180° using a wrench.

### DIMENSIONS AND PARAMETERS

OD	DNK	H	B	L	Hb	E	C	Fp	m
mm	mm	mm	mm	mm	mm	mm	mm	kN	kg
57	057	74	60	180	50	80	40	6,4	2,2
60,3	050	76	60	180	50	80	40	6,4	2,2
73	073	85	60	180	50	80	40	6,4	2,4
76,1	065	87	60	180	50	80	40	6,4	2,4
88,9	080	94	60	180	50	80	40	6,4	2,6
108	108	111	80	220	60	100	50	11,4	4,1
114,3	100	115	80	220	60	100	50	11,4	4,3
127	127	123	80	220	60	100	50	11,4	4,5
133	133	126	80	220	60	100	50	11,4	4,6
139,7	125	130	80	220	60	100	50	11,4	4,7
141,3	141	131	80	220	60	100	50	11,4	4,8
159	159	129	120	220	60	100	50	11,4	5,8
168,3	150	135	120	220	60	100	50	11,4	6,0
193,7	175	150	120	220	60	100	50	11,4	6,5
219,1	200	165	120	220	60	100	50	13,8	7,0
244,5	225	179	120	260	60	120	60	13,8	10,4
273	250	205	160	260	80	120	60	13,8	12,5
323,9	300	234	160	260	80	120	60	13,8	13,7
355,6	350	251	160	260	80	120	60	16,2	14,4
377	377	263	160	260	80	120	60	16,2	14,9
406,4	400	290	210	300	100	140	70	16,1	23,6
426	426	301	210	300	100	140	70	16,1	24,3
457	450	318	210	300	100	140	70	16,1	25,4
508	500	324	300	300	100	140	70	22,4	30,7
530	530	337	300	300	100	140	70	22,4	31,5
559	550	359	300	380	100	180	90	29,2	57,7
609,6	600	394	350	380	120	180	90	38,2	63,2
630	630	406	350	380	120	180	90	38,2	64,6
664	650	423	350	380	120	180	90	33,3	66,9
711,2	700	428	430	380	120	180	90	33,3	71,8
720	720	434	430	380	120	180	90	33,3	72,5
762	750	459	430	380	120	180	90	33,3	75,4
812,8	800	488	430	380	120	180	90	33,3	78,7
820	820	492	430	380	120	180	90	33,3	79,3

### MATERIAL GROUPS

MS No.	1	4
Tmax (°C)	350	400
Material	S235JR	1.4301

### DESIGN VERSIONS

Sliding surfaces (KP):

S – steel

M – stainless steel mirror

T – PTFE plate with diameter Dt = B - 5 mm (see 2.10.)

### PŘÍPUSTNÁ ZATÍŽENÍ

Resultant external force must satisfy the following equation for total load:  $F_x/F_p + F_y/F_p + F_z/F_p \leq 1$ , where  $F_x$  is a force in the direction of pipe axis and  $F_y$  is a horizontal force perpendicular to the pipe axis. The  $F_x$  and  $F_y$  components do not include the friction forces generated by vertical component  $F_z$ . The load-bearing capacity at higher temperatures and for different materials shall satisfy the following equation:  $F_{pt,M}^G = k_{t,M} \times F_p$ , where the correction factor is specified according to table 1.1.

## 25-3

Support with standard or optional height. Support height H can be specified in the interval  $0.5 \times H$  to  $1.2 \times H$ .

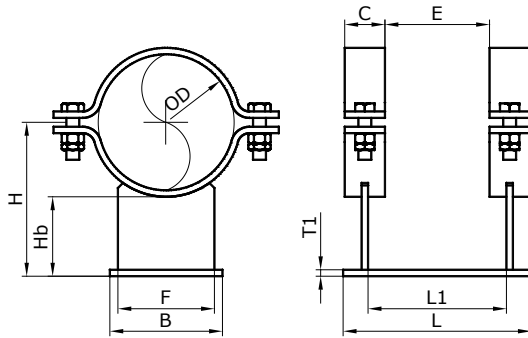

### DESIGNATION

#### 25-3 MS-DNK-H-KP

Example of designation: 25-31-100-220

DNK – pipe outer diameter code

H – required support height

MS – material group code

KP – sliding surface code

### ASSEMBLY

The clamp bolts are to be hand-tightened until the clamp is in full contact with the pipe and then the bolts to be tightened by 180° using a wrench.

### DIMENSIONS AND PARAMETERS

OD	DNK	H	B	L	Hb	E	C	F	T1	L1	Fp	m
mm	mm	mm	mm	mm	mm	mm	mm	mm	mm	mm	kN	kg
57	057	155	80	200	121	100	40	50	8	134	4,4	2,9
60,3	050	155	80	200	119	100	40	50	8	134	4,4	2,9
73	073	165	85	200	123	100	40	60	8	134	5,3	3,3
76,1	065	165	85	200	121	100	40	60	8	134	5,3	3,3
88,9	080	170	85	200	120	100	40	60	8	134	5,4	3,5
108	108	200	100	240	138	120	50	80	10	162	7,9	6,4
114,3	100	200	100	240	135	120	50	80	10	162	7,9	6,5
127	127	220	120	240	149	120	50	100	10	162	9,5	7,7
133	133	220	120	240	146	120	50	100	10	162	9,5	7,8
139,7	125	220	120	240	142	120	50	100	10	162	9,5	7,9
141,3	141	220	120	240	141	120	50	100	10	162	9,5	7,9
159	159	240	120	240	153	120	50	100	10	162	9,5	8,4
168,3	150	240	120	240	148	120	50	100	10	162	9,5	8,6
193,7	175	270	140	240	165	120	50	120	10	162	11,1	10,1
219,1	200	290	150	240	172	120	50	130	10	162	11,9	11,2
244,5	225	300	150	240	170	100	60	130	12	150	17,1	15,7
273	250	330	165	300	186	160	60	145	12	210	15,7	18,7
323,9	300	380	190	300	210	160	60	170	12	210	18,0	22,2
355,6	350	400	200	300	214	160	60	180	12	210	19,0	23,7
377	377	400	200	300	204	160	60	180	12	210	19,0	23,9
406,4	400	430	205	350	217	190	70	185	15	248	26,1	36,7
426	426	430	205	350	207	190	70	185	15	248	26,1	37,1
457	450	470	225	350	232	190	70	200	15	248	28,6	40,8
508	500	500	230	350	236	190	70	210	15	248	29,2	43,4
530	530	500	230	350	225	190	70	210	15	248	29,2	43,7
559	550	530	240	350	236	150	90	220	15	228	30,5	68,9
609,6	600	560	255	450	240	250	90	225	15	328	25,2	77,6
630	630	560	255	450	230	250	90	225	15	328	25,2	78,5
664	650	590	270	450	243	250	90	240	20	325	38,8	85,8
711,2	700	630	290	450	259	250	90	260	20	325	46,7	92,4
720	720	630	320	450	255	250	90	290	20	325	46,7	96,7
762	750	670	340	450	274	250	90	310	20	325	49,2	103,6
812,8	800	700	340	450	279	250	90	310	20	325	48,9	107,3
820	820	700	340	450	275	250	90	310	20	325	48,9	107,6

### MATERIAL GROUPS

MS No.	1	2	3	4	5	6	7
Tmax (°C)	350	500	580	400	500	620	350
Material	S235JR	16Mo3	10CrMo910	1.4301	1.4571	1.4948	P275NH

### DESIGN VERSIONS

Sliding surfaces (KP): S – steel, M – stainless steel mirror, T – PTFE plate with diameter of  $D_t = B - 5$  mm (see 2.10.)

### PERMISSIBLE LOADS

Resultant external force must satisfy the following equation for total load:  $2.5 \times F_x/F_p + 0.75 \times F_y/F_p + F_z/F_p \leq 1$ , where  $F_x$  is a force in the direction of pipe axis and  $F_y$  is a horizontal force perpendicular to the pipe axis. The  $F_x$  and  $F_y$  components do not include the friction forces generated by vertical component  $F_z$ . The load-bearing capacity at higher temperatures and for different materials shall satisfy the following equation:  $F_{pt,M}^G = k_{t,M} \times F_p$ , where the correction factor is specified according to table 1.1.

25-4

Support with standard or optional height support. Support height H can be specified in the interval  $0.5 \times H$  to  $1.2 \times H$ .

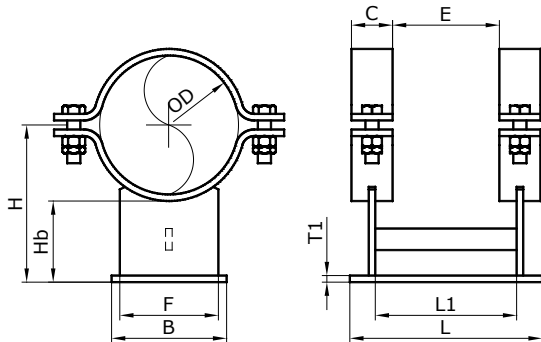

DESIGNATION

25-4 MS-DNK-H-KP

Example of designation: 25-43-377-420-T

- DNK – pipe outer diameter code
- H – required support height
- MS – material group code
- KP – sliding surface code

ASSEMBLY

The clamp bolts are to be hand-tightened until the clamp is in full contact with the pipe and then the bolts to be tightened by 180° using a wrench.

DIMENSIONS AND PARAMETERS

OD	DNK	H	B	L	Hb	E	C	F	T1	L1	Fp	m
mm	mm	mm	mm	mm	mm	mm	mm	mm	mm	mm	kN	kg
57	057	155	80	200	121	100	40	50	8	134	7,5	3,1
60,3	050	155	80	200	119	100	40	50	8	134	7,5	3,1
73	073	165	85	200	123	100	40	60	8	134	9,4	3,5
76,1	065	165	85	200	121	100	40	60	8	134	9,4	3,5
88,9	080	170	85	200	120	100	40	60	8	134	9,5	3,6
108	108	200	100	240	138	120	50	80	10	162	12,9	6,5
114,3	100	200	100	240	135	120	50	80	10	162	12,9	6,6
127	127	220	120	240	149	120	50	100	10	162	15,4	7,7
133	133	220	120	240	146	120	50	100	10	162	15,4	7,8
139,7	125	220	120	240	142	120	50	100	10	162	15,4	7,8
141,3	141	220	120	240	141	120	50	100	10	162	15,4	7,9
159	159	240	120	240	153	120	50	100	10	162	15,4	8,5
168,3	150	240	120	240	148	120	50	100	10	162	15,4	8,6
193,7	175	270	140	240	165	120	50	120	10	162	18,0	10,1
219,1	200	290	150	240	172	120	50	130	10	162	19,3	11,1
244,5	225	300	150	240	170	100	60	130	12	150	27,8	15,4
273	250	330	165	300	186	160	60	145	12	210	21,5	18,5
323,9	300	380	190	300	210	160	60	170	12	210	24,8	21,8
355,6	350	400	200	300	214	160	60	180	12	210	26,1	23,3
377	377	400	200	300	204	160	60	180	12	210	26,1	23,5
406,4	400	430	205	350	217	190	70	185	15	248	32,1	35,3
426	426	430	205	350	207	190	70	185	15	248	32,1	35,7
457	450	470	225	350	232	190	70	200	15	248	35,2	39,1
508	500	500	230	350	236	190	70	210	15	248	36,0	42,1
530	530	500	230	350	225	190	70	210	15	248	36,0	42,4
559	550	530	240	350	236	150	90	220	15	228	37,5	67,3
609,6	600	560	255	450	240	250	90	225	15	328	27,0	75,5
630	630	560	255	450	230	250	90	225	15	328	27,0	76,4
664	650	590	270	450	243	250	90	240	20	325	50,8	88,9
711,2	700	630	290	450	259	250	90	260	20	325	60,2	96,2
720	720	630	320	450	255	250	90	290	20	325	60,2	100,5
762	750	670	340	450	274	250	90	310	20	325	64,0	107,4
812,8	800	700	340	450	279	250	90	310	20	325	64,0	111,1
820	820	700	340	450	275	250	90	310	20	325	64,0	111,4

MATERIAL GROUPS

MS No.	1	2	3	4	5	6	7
Tmax (°C)	350	500	580	400	500	620	350
Material	S235JR	16Mo3	10CrMo910	1.4301	1.4571	1.4948	P275NH

DESIGN VERSIONS

Sliding surfaces (KP): S – steel, M – stainless steel mirror, T – PTFE plate with the diameter of  $Dt = B - 5$  mm (see 2.10.), B – bronze-graphite plate

PERMISSIBLE LOADS

Resultant external force must satisfy the following equation for total load:  $2.5 \times F_x/F_p + 0.75 \times F_y/F_p + F_z/F_p \leq 1$ , where  $F_x$  is a force in the direction of pipe axis and  $F_y$  is a horizontal force perpendicular to the pipe axis. The  $F_x$  and  $F_y$  components do not include the friction forces generated by vertical component  $F_z$ . The load-bearing capacity at higher temperatures and for different materials shall satisfy the following equation:  $F_{pt,M}^G = k_{t,M} \times F_{pr}$  where the correction factor is specified according to table 11.

## 25-5

Support of high load capacity with standard or optional height. Support height H can be specified in the interval  $0.5 \times H$  to  $1.33 \times H$ . Also available in long version.

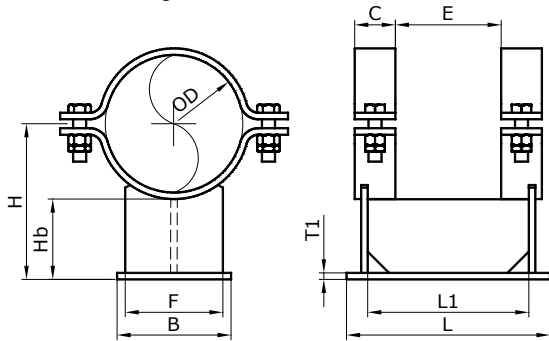

### DESIGNATION

#### 25-5(L) MS-DNK-H-KP

Example of designation: 25-5L6-400-400-T

DNK – pipe outer diameter code

H – required support height

MS – material group code

KP – sliding surface code

L – long version, the character is not normally specified

### ASSEMBLY

The clamp bolts are to be hand-tightened until the clamp is in full contact with the pipe and then the bolts to be tightened by 180° using a wrench.

### DIMENSIONS AND PARAMETERS

OD	DNK	H	B	L	Hb	E	C	F	T1	L1	Fp	m
mm	mm	mm	mm	mm	mm	mm	mm	mm	mm	mm	kN	kg
57	057	155	90	200	121	100	40	70	6	168	10,5	3,8
60,3	050	155	90	200	119	100	40	70	6	168	10,5	3,8
73	073	165	100	200	123	100	40	80	6	168	11,8	4,2
76,1	065	165	100	200	121	100	40	80	6	168	11,8	4,3
88,9	080	170	110	200	120	100	40	90	6	168	13,5	4,6
108	108	200	120	240	138	120	50	100	8	204	21,8	7,9
114,3	100	200	120	240	135	120	50	100	8	204	21,8	7,9
127	127	220	135	240	149	120	50	115	8	204	23,7	9,0
133	133	220	135	240	146	120	50	115	8	204	23,7	9,1
139,7	125	220	135	240	142	120	50	115	8	204	23,7	9,1
141,3	141	220	135	240	141	120	50	115	8	204	23,7	9,1
159	159	240	145	240	153	120	50	120	8	204	24,2	10,0
168,3	150	240	145	240	148	120	50	120	8	204	24,2	10,1
193,7	175	270	160	240	165	120	50	135	8	204	25,5	11,6
219,1	200	290	165	240	172	120	50	140	8	204	25,5	12,5
244,5	225	300	170	240	170	100	60	145	10	200	34,5	17,4
273	250	330	190	300	186	160	60	165	10	260	41,4	21,3
323,9	300	380	210	300	210	160	60	185	10	260	41,8	24,8
355,6	350	400	230	300	214	160	60	200	10	260	44,0	26,7
377	377	400	230	300	204	160	60	200	10	260	44,0	26,7
406,4	400	430	230	350	217	190	70	200	12	306	60,4	39,2
426	426	430	230	350	207	190	70	200	12	306	60,4	39,3
457	450	470	255	350	232	190	70	225	12	306	63,9	43,9
508	500	500	260	350	236	190	70	230	12	306	64,2	46,4
530	530	500	260	350	225	190	70	230	12	306	64,2	46,3
559	550	530	275	350	236	150	90	245	12	306	67,7	71,9
609,6	600	560	290	450	240	250	90	260	12	406	85,0	81,5
630	630	560	290	450	230	250	90	260	12	406	85,0	82,0
664	650	590	300	450	243	250	90	270	15	400	88,5	94,3
711,2	700	630	350	450	259	250	90	320	15	400	98,2	105
720	720	630	350	450	255	250	90	320	15	400	98,2	105
762	750	670	360	450	274	250	90	330	15	400	96,9	111
812,8	800	700	360	450	279	250	90	330	15	400	95,8	115
820	820	700	360	450	275	250	90	330	15	400	95,8	115

### MATERIAL GROUPS

MS No.	1	2	3	4	5	6	7
Tmax (°C)	350	500	580	400	500	620	350
Material	S235JR	16Mo3	10CrMo910	1.4301	1.4571	1.4948	P275NH

### DESIGN VERSIONS

Sliding surfaces (KP): S – steel, M – stainless steel mirror, T – PTFE plate with the diameter of  $D_t = B - 5$  mm (see 2.10.), B – bronze-graphite plate  
Long version – the support length is 1.5 times longer than the standard length L. Other dimensions remain unchanged; the weight is 1.5 times the tabular value of m.

### PERMISSIBLE LOADS

Resultant external force must satisfy the following equation for total load:  $F_x/F_p + 1.5 \times F_y/F_p + F_z/F_p \leq 1$ , where  $F_x$  is a force in the direction of pipe axis and  $F_y$  is a horizontal force perpendicular to the pipe axis. The  $F_x$  and  $F_y$  components do not include the friction forces generated by vertical component  $F_z$ . The load-bearing capacity at higher temperatures and for different materials shall satisfy the following equation:  $F_{pt,M}^G = k_{t,M} \times F_{pt}$  where the correction factor is specified according to table 1.1.

25-6

Heavy high support. Support height H can be specified in the interval  $0.5 \times H$  to  $1.2 \times H$ .

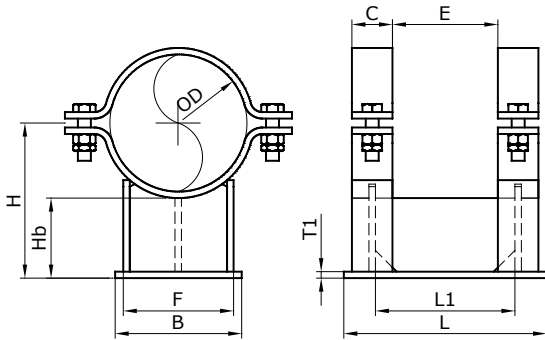

DESIGNATION

25-6(L) MS-DNK-H-KP

Example of designation: 25-67-133-275-M

- DNK – pipe outer diameter code
- H – required support height
- MS – material group code
- KP – sliding surface code

ASSEMBLY

The clamp bolts are to be hand-tightened until the clamp is in full contact with the pipe and then the bolts to be tightened by 180° using a wrench.

DIMENSIONS AND PARAMETERS

OD	DNK	H	B	L	Hb	E	C	F	T1	L1	Fp	m
mm	mm	mm	mm	mm	mm	mm	mm	mm	mm	mm	kN	kg
57	057	179	115	260	150	160	40	68	8	194	18,7	6,9
60,3	050	180	115	260	150	160	40	68	8	194	18,7	6,9
73	073	207	130	260	170	160	40	73	8	194	18,0	7,8
76,1	065	208	130	260	170	160	40	73	8	194	18,0	7,8
88,9	080	214	130	260	170	160	40	83	8	194	19,1	8,0
108	108	234	140	320	180	200	50	101	10	242	31,9	13,6
114,3	100	237	140	320	180	200	50	101	10	242	31,9	13,7
127	127	264	160	320	200	200	50	121	10	242	32,7	15,5
133	133	267	160	320	200	200	50	121	10	242	32,7	15,6
139,7	125	270	160	320	200	200	50	121	10	242	32,7	15,7
141,3	141	271	160	320	200	200	50	121	10	242	32,7	15,7
159	159	280	170	320	200	200	50	131	12	242	38,8	17,1
168,3	150	284	170	320	200	200	50	131	12	242	38,8	17,3
193,7	175	317	190	320	220	200	50	151	12	242	39,0	19,4
219,1	200	330	190	320	220	200	50	151	15	242	45,9	21,1
244,5	225	342	200	400	220	260	60	161	15	310	49,2	31,3
273	250	377	215	400	240	260	60	176	15	310	60,4	34,1
323,9	300	422	235	400	260	260	60	196	15	310	60,2	37,6
355,6	350	448	255	400	270	260	60	216	20	310	75,2	43,8
377	377	459	255	400	270	260	60	216	20	310	75,2	44,2
406,4	400	473	270	460	270	300	70	231	20	358	96,8	61,1
426	426	483	270	460	270	300	70	231	20	358	96,8	61,7
457	450	529	290	460	300	300	70	251	20	358	94,5	67,1
508	500	554	310	480	300	320	70	271	20	378	96,5	72,6
530	530	565	310	480	300	320	70	271	20	378	96,5	73,2
559	550	600	325	600	320	400	90	286	20	478	95,8	114
609,6	600	625	345	600	320	400	90	306	25	478	156,2	127
630	630	635	345	600	320	400	90	306	25	478	156,2	128
664	650	650	350	600	320	400	90	311	25	475	156,8	140
711,2	700	696	375	600	340	400	90	336	25	475	155,5	149
720	720	700	375	600	340	400	90	336	25	475	155,5	150
762	750	721	385	600	340	400	90	346	25	475	156,6	154
812,8	800	757	405	600	350	400	90	366	25	475	156,5	161
820	820	760	405	600	350	400	90	366	25	475	156,5	162

MATERIAL GROUPS

MS No.	1	2	3	4	5	6	7
Tmax (°C)	350	500	580	400	500	620	350
Material	S235JR	16Mo3	10CrMo910	1.4301	1.4571	1.4948	P275NH

DESIGN VERSIONS

Sliding surfaces (KP): S – steel, M – stainless steel mirror, T – PTFE plate with the diameter of  $Dt = B - 5$  mm (see 2.10.), B – bronze-graphite plate Long version – the support length is 1.5 times longer than the standard length L. Other dimensions remain unchanged; the weight is 1.5 times the tabular value of m.

PERMISSIBLE LOADS

Resultant external force must satisfy the following equation for total load:  $0.5 \times F_x/F_p + 1.5 \times F_y/F_p + F_z/F_p \leq 1$ , where  $F_x$  is a force in the direction of pipe axis and  $F_y$  is a horizontal force perpendicular to the pipe axis. The  $F_x$  and  $F_y$  components do not include the friction forces generated by vertical component  $F_z$ . The load-bearing capacity at higher temperatures and for different materials shall satisfy the following equation:  $F_{pt,M}^G = k_{c,M} \times F_{p'}^G$  where the correction factor is specified according to table 1.1.

## 25-8

Support with adjustable height. The support height H can be adjusted in the range of  $H_{min}$  to  $H_{max}$ . Also available in long version.

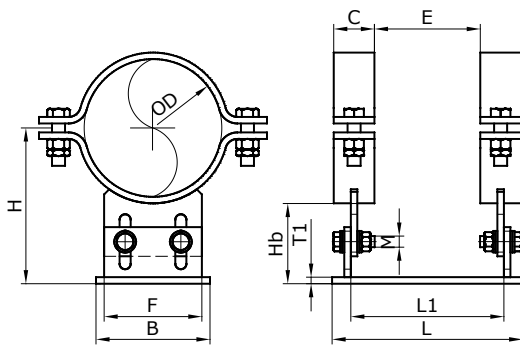

## DESIGNATION

## 25-8 MS-DNK-H-KP

Příklad označení: 25-82-100-220-M-L

DNK – pipe outer diameter code

H – required support height

MS – material group code

KP – sliding surface code

## ASSEMBLY

The clamp bolts are to be hand-tightened until the clamp is in full contact with the pipe and then the bolts to be tightened by 180° using a wrench.

Tightening torque for height adjustment connection bolts:

M (mm)	10	12	16	20	24
Mt (N×m)	40	75	150	300	500

## DIMENSIONS AND PARAMETERS

OD	DNK	H	Hmin	Hmax	B	L	M	Hb	E	C	F	T1	L1	Fp	m
mm	mm	mm	mm	mm	mm	mm	mm	mm	mm	mm	mm	mm	mm	kN	kg
57	057	155	138	173	80	200	10	121	100	40	50	8	134	4,4	2,9
60,3	050	155	138	173	80	200	10	119	100	40	50	8	134	4,4	2,9
73	073	165	147	184	85	200	10	123	100	40	60	8	134	5,3	3,3
76,1	065	165	148	183	85	200	10	121	100	40	60	8	134	5,3	3,3
88,9	080	170	155	186	85	200	12	120	100	40	60	8	134	5,4	3,5
108	108	200	182	219	100	240	12	138	120	50	80	10	162	7,9	6,1
114,3	100	200	183	218	100	240	12	135	120	50	80	10	162	7,9	6,1
127	127	220	199	242	120	240	12	149	120	50	100	10	162	9,5	7,3
133	133	220	200	241	120	240	12	146	120	50	100	10	162	9,5	7,4
139,7	125	220	201	240	120	240	12	142	120	50	100	10	162	9,5	7,4
141,3	141	220	201	240	120	240	12	141	120	50	100	10	162	9,5	7,5
159	159	240	218	263	120	240	12	153	120	50	100	10	162	9,5	8,0
168,3	150	240	220	261	120	240	12	148	120	50	100	10	162	9,5	8,1
193,7	175	270	249	292	140	240	16	165	120	50	120	10	162	11,1	9,6
219,1	200	290	267	314	150	240	16	172	120	50	130	10	162	11,9	10,6
244,5	225	300	280	321	150	240	16	170	100	60	130	12	150	17,1	14,8
273	250	330	306	355	165	300	16	186	160	60	145	12	210	15,7	17,5
323,9	300	380	349	412	190	300	16	210	160	60	170	12	210	18,0	21
355,6	350	400	368	433	200	300	16	214	160	60	180	12	210	19,0	22
377	377	400	371	430	200	300	16	204	160	60	180	12	210	19,0	22
406,4	400	430	404	457	205	350	20	217	190	70	185	15	248	26,1	34
426	426	430	406	455	205	350	20	207	190	70	185	15	248	26,1	34
457	450	470	440	501	225	350	20	232	190	70	200	15	248	28,6	38
508	500	500	469	532	230	350	20	236	190	70	210	15	248	29,2	40
530	530	500	472	529	230	350	20	225	190	70	210	15	248	29,2	41
559	550	530	498	563	240	350	20	236	150	90	220	15	228	30,5	66
609,6	600	560	531	590	255	450	24	240	250	90	225	15	328	25,2	73
630	630	560	533	588	255	450	24	230	250	90	225	15	328	25,2	74
664	650	590	559	621	270	450	24	243	250	90	240	20	325	38,8	86
711,2	700	630	596	665	290	450	24	259	250	90	260	20	325	46,7	92
720	720	630	597	664	320	450	24	255	250	90	290	20	325	46,7	97
762	750	670	632	709	340	450	24	274	250	90	310	20	325	49,2	104
812,8	800	700	661	740	340	450	24	279	250	90	310	20	325	48,9	107
820	820	700	957	600	300	510	90	757	30	80	22	22,0	88,2	147,1	30,1

## MATERIAL GROUPS

MS No.	1	2	4	5	7	6	7
Tmax (°C)	350	500	400	500	350	620	350
Material	S235JR	16Mo3	1.4301	1.4571	P275NH	1.4948	P275NH

## DESIGN VERSIONS

Sliding surfaces (KP): S – steel, M – stainless steel mirror, T – PTFE plate with the diameter of  $Dt = B - 5$  mm (see 2.10.)

Long version – the support length is 1.5 times longer than the standard length L. Other dimensions remain unchanged; the weight is 1.5 times the tabular value of m.

## PŘÍPUSTNÁ ZATÍŽENÍ

Resultant external force must satisfy the following equation for total load:  $F_i \leq F_{pi}$  and  $M_i \leq M_{pi}$ .

The load-bearing capacity at higher temperatures and for different materials shall satisfy the following equation:  $F_{pt,M}^G = k_{t,M} \times F_{pt}$ , where the correction factor is specified according to table 1.1.

26-1

Anchor base. Support height H cannot be changed.

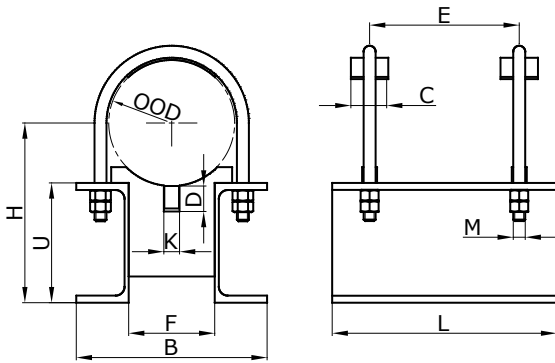

DESIGNATION

**26-1 MS-DNK**  
 Example of designation: 26-1 MS-DNK

DNK – pipe outer diameter code  
 MS – material group code

ASSEMBLY

The support is assembled by bolting the U-bolts (with the guard plates that are inserted between the U-bolts and the pipe) to the support base and tightening their nuts to required tightening torque, according to the table below. If it is required to restrain moment acting in axial pipe direction (i.e. torque) a flat shear lug is welded to the pipe on both sides of the anchor base – this shear lugs are positioned in the openings (D × K dimensions) cut-out in the anchor base.

DIMENSIONS AND PARAMETERS

OD	DNK	H	B	L	U	E	C	F	M	D	K	Fpx	Fpy	Fpz	Mpx	Mpy	Mpz	m
mm	mm	mm	mm	mm	mm	mm	mm	mm	mm	mm	mm	kN	kN	kN	kN	kN	kN	kg
57	057	155	150	260	100	230	30	40	10	40	10	2,2	9,0	15,1	0,2	1,7	2,0	5,9
60,3	050	155	150	260	100	230	30	40	10	40	10	2,2	9,0	15,1	0,2	1,7	2,0	5,9
73	073	165	150	260	100	224	36	40	12	40	10	3,2	13,2	22,1	0,4	2,4	2,9	6,2
76,1	065	165	150	260	100	224	36	40	12	40	10	3,2	13,2	22,1	0,4	2,4	2,9	6,2
88,9	080	170	156	260	100	224	36	46	12	40	10	3,2	13,2	22,1	0,4	2,4	2,9	6,4
108	108	200	185	320	120	272	48	65	16	40	10	6,0	24,6	41,1	1,1	5,5	6,6	10,4
114,3	100	200	191	320	120	272	48	71	16	40	10	6,0	24,6	41,1	1,1	5,5	6,6	10,5
127	127	220	208	320	140	272	48	78	16	50	12	6,0	24,6	41,1	1,3	5,5	6,6	12,5
133	133	220	214	320	140	272	48	84	16	50	12	6,0	24,6	41,1	1,3	5,5	6,6	12,7
139,7	125	220	221	320	140	272	48	91	16	50	12	6,0	24,6	41,1	1,4	5,5	6,6	12,9
141,3	141	220	222	320	140	272	48	92	16	50	12	6,0	24,6	41,1	1,4	5,5	6,6	13,0
159	159	240	244	320	160	272	48	104	16	50	12	6,0	24,6	41,1	1,6	5,5	6,6	15,4
168,3	150	240	253	320	160	272	48	113	16	50	12	6,0	24,6	41,1	1,7	5,5	6,6	15,7
193,7	175	270	279	320	160	272	48	139	16	50	12	6,0	24,6	41,1	1,9	5,5	6,6	18,1
219,1	200	290	313	320	180	260	60	173	20	60	16	9,6	38,4	64,2	3,5	8,3	9,9	22,0
244,5	225	300	339	400	180	340	60	199	20	60	16	9,6	38,4	64,2	3,9	10,9	13,0	26
273	250	330	375	400	200	340	60	215	20	60	16	9,6	38,4	64,2	4,3	10,9	13,0	33
323,9	300	380	430	400	220	340	60	260	20	60	16	9,6	38,4	64,2	5,1	10,9	13,0	44
355,6	350	400	462	400	220	340	60	292	20	60	16	9,6	38,4	64,2	5,7	10,9	13,0	46
377	377	400	483	400	220	340	60	313	20	60	16	9,6	38,4	64,2	6,0	10,9	13,0	48
406,4	400	430	520	460	220	388	72	350	24	80	22	13,8	55,4	92,6	9,4	17,9	21,4	63
426	426	430	540	460	220	388	72	370	24	80	22	13,8	55,4	92,6	9,8	17,9	21,4	65
457	450	470	575	460	240	388	72	395	24	80	22	13,8	55,4	92,6	10,5	17,9	21,4	69
508	500	500	627	480	240	408	72	447	24	80	22	13,8	55,4	92,6	11,7	18,8	22,6	82
530	530	500	649	480	240	408	72	469	24	80	22	13,8	55,4	92,6	12,2	18,8	22,6	84
559	550	530	678	600	240	528	72	498	24	80	22	13,8	55,4	92,6	12,9	24,4	29,2	95
609,6	600	560	739	600	240	510	90	559	30	80	22	22,0	88,2	147,1	22,4	37,5	44,9	120
630	630	560	759	600	240	510	90	579	30	80	22	22,0	88,2	147,1	23,1	37,5	44,9	123
664	650	590	793	600	240	510	90	613	30	80	22	22,0	88,2	147,1	24,4	37,5	44,9	128
711,2	700	630	844	600	270	510	90	654	30	80	22	22,0	88,2	147,1	26,1	37,5	44,9	149
720	720	630	853	600	270	510	90	663	30	80	22	22,0	88,2	147,1	26,4	37,5	44,9	150
762	750	670	895	600	270	510	90	705	30	80	22	22,0	88,2	147,1	28,0	37,5	44,9	157
812,8	800	700	950	600	300	510	90	750	30	80	22	22,0	88,2	147,1	29,8	37,5	44,9	185
820	820	700	957	600	300	510	90	757	30	80	22	22,0	88,2	147,1	30,1	37,5	44,9	186

MATERIAL GROUPS

MS No.	1	2	4	5	7	6	7
Tmax (°C)	350	500	400	500	350	620	350
Material	S235JR	16Mo3	1.4301	1.4571	P275NH	1.4948	P275NH

TIGHTENING TORQUE FOR U-BOLTS

U-bolt size	M12	M16	M20	M24	M30
Torque(N.m)	20	40	80	150	300

PERMISSIBLE LOADS

Resultant external force must satisfy the following equation for total load:  $F_i \leq F_{pi}$  and  $M_i \leq M_{pi}$ . The load-bearing capacity at higher temperatures and for different materials shall satisfy the following equation:  $F_{pt,M}^G = k_{t,M} \times F_p$ , where the correction factor is specified according to table 1.1.



## 27-1

Guided support for piping on pipe racks. Support height cannot be changed.

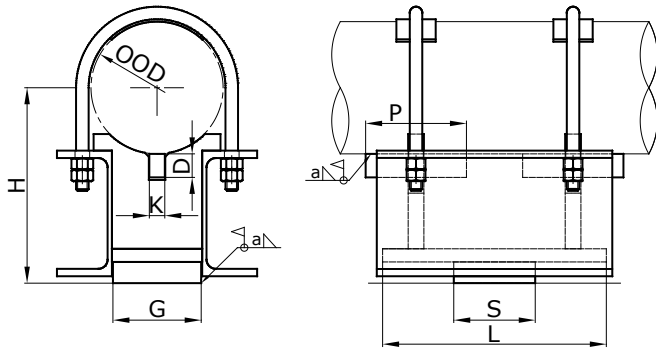

## DESIGNATION

## 27-1 MS-DNK

Example of designation: 27-12-200-M

DNK – pipe outer diameter code

MS – material group code

KP – sliding surface code

## ASSEMBLY

A slide plate with dimensions  $G \times S$ , is welded to the supporting steel structure. It is important to maintain its axial alignment with the pipe. A flat shear lug is welded to the pipe on both sides of the support base – this shear lugs are positioned in the openings ( $D \times K$  dimensions) cut-out in the anchor base. The support is assembled by bolting the U-bolts (with the guard plates that are inserted between the U-bolts and the pipe) to the support base and tightening their nuts to required tightening torque, according to the table for type 26-1.

## DIMENSIONS AND PARAMETERS

OD	DNK	H	G	S	L	D	K	P	F <sub>py</sub>	F <sub>pz</sub>	m
mm	mm	mm	mm	mm	mm	mm	mm	mm	kN	kN	kg
108	108	208	63	100	300	36	12	80	24,6	41,1	13,1
114,3	100	208	69	100	300	36	12	80	24,6	41,1	13,5
127	127	228	76	100	300	36	12	80	24,6	41,1	15,7
133	133	228	82	100	300	36	12	80	24,6	41,1	16,1
139,7	125	228	88	100	300	36	12	80	24,6	41,1	16,6
141,3	141	228	90	120	300	36	12	80	24,6	41,1	16,9
159	159	248	102	120	300	45	15	80	24,6	41,1	20,1
168,3	150	248	111	120	300	45	15	80	24,6	41,1	20,8
193,7	175	278	136	120	300	45	15	80	24,6	41,1	24,0
219,1	200	300	171	140	300	50	20	80	38,4	64,2	33,0
244,5	225	310	196	160	380	50	20	100	38,4	64,2	41,4
273	250	340	212	160	380	50	20	100	38,4	64,2	49,6
323,9	300	390	256	160	380	50	25	100	38,4	64,2	63,4
355,6	350	410	288	160	380	50	25	100	38,4	64,2	74,3
377	377	410	310	160	380	50	25	100	38,4	64,2	78,0
406,4	400	442	347	184	440	50	30	115	55,4	92,6	96,4
426	426	442	367	184	440	50	30	115	55,4	92,6	100,2
457	450	482	392	184	440	50	30	115	55,4	92,6	106,6
508	500	512	444	192	460	50	40	120	55,4	92,6	137,6
530	530	512	466	192	460	50	40	120	55,4	92,6	142,7
559	550	542	495	240	580	50	40	120	55,4	92,6	171,5
609,6	600	572	555	240	580	50	40	120	88,2	147,1	205,6
630	630	572	576	240	580	50	40	120	88,2	147,1	211,6
664	650	602	610	240	580	50	40	120	88,2	147,1	221,6
711,2	700	642	651	240	580	50	50	120	88,2	147,1	249,4
720	720	642	660	240	580	50	50	120	88,2	147,1	252,1
762	750	682	702	240	580	50	50	120	88,2	147,1	265,0
812,8	800	712	746	240	580	50	50	120	88,2	147,1	299,7
820	820	712	754	240	580	50	50	120	88,2	147,1	302,1

## MATERIAL GROUPS

MS No.	1	2	4	5	7	6	7
Tmax (°C)	350	500	400	500	350	620	350
Material	S235JR	16Mo3	1.4301	1.4571	P275NH	1.4948	P275NH

## DESIGN VERSIONS

Sliding surfaces (KP):

S – steel

M – stainless steel mirror and PTFE plate

B – bronze-graphite plate

## PERMISSIBLE LOADS

Resultant external force must satisfy the following equation for total load:  $F_y/F_p + F_z/F_p \leq 1$ .

The load-bearing capacity at higher temperatures and for different materials shall satisfy the following equation:

$F_{pt,M}^G = k_{t,M} \times F_{pr}$  where the correction factor is specified according to table 1.1.

## 29-1

Support for vertical pipes. It can also be used for guiding in the axial direction of the brackets.

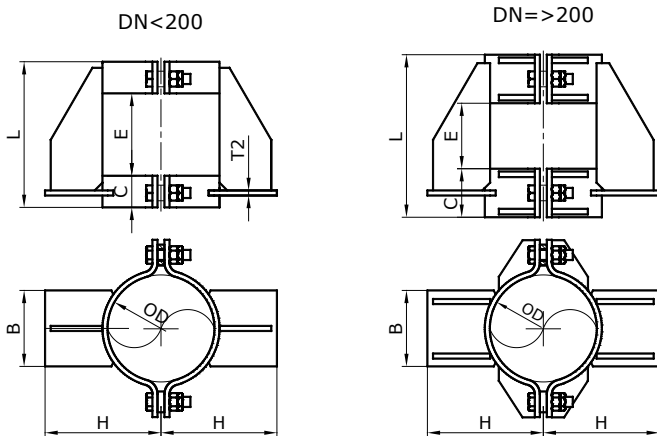

### DESIGNATION

#### 29-1 MS-DNK-KP

Example of designation: 29-12-159

DNK – pipe outer diameter code

MS – material group code

### ASSEMBLY

The clamp bolts are to be hand-tightened until the clamp is in full contact with the pipe and then the bolts are to be tightened by 180° using a wrench.

For all dimensions, it is recommended to weld flat shear lugs to the pipe wall to prevent the clamps from slipping.

### DIMENSIONS AND PARAMETERS

DNK	Do	H	L	B	C	E	T2	Fp	m
mm	mm	mm	mm	mm	mm	mm	mm	kN	kg
57	57	155	200	80	40	120	6	2,5	3,9
50	60,3	155	200	80	40	120	6	2,5	3,9
73	73	165	200	85	40	120	6	2,5	4,3
65	76,1	165	200	85	40	120	6	2,5	4,2
80	88,9	170	200	85	40	120	6	2,5	4,3
108	108	200	240	100	50	140	8	11,4	7,6
100	114,3	200	240	100	50	140	8	11,4	7,4
127	127	220	240	120	50	140	8	13,9	8,8
133	133	220	240	120	50	140	8	13,9	8,6
125	139,7	220	240	120	50	140	8	13,9	8,7
141	141,3	220	240	120	50	140	8	13,9	8,7
159	159	240	240	120	50	140	8	17,1	9,4
150	168,3	240	240	120	50	140	8	17,1	9,5
175	193,7	270	240	140	50	140	8	17,1	11
200	219,1	290	240	150	70	160	8	20,9	16
225	244,5	300	240	150	70	180	8	20,9	21,2
250	273	330	300	165	80	200	8	27,0	24,2
300	323,9	380	300	190	80	240	8	26,2	29,5
350	355,6	400	300	200	80	280	8	28,7	34
377	377	400	300	200	80	300	8	28,7	35,8
400	406,4	430	350	205	100	320	10	30,0	49,7
426	426	430	350	205	100	340	10	30,0	52,5
450	457	470	350	225	100	360	10	30,8	59,5
500	508	500	350	230	100	400	10	33,2	63,8
530	530	500	350	230	100	420	10	33,2	65,8
550	559	530	350	240	100	440	15	34,6	112,8
600	609,6	560	450	255	120	480	15	38,9	118,8
630	630	560	450	255	120	500	15	38,9	124,5
650	664	590	450	270	120	520	15	39,3	134,9
700	711,2	630	450	290	120	560	15	41,8	148,3
720	720	630	450	320	120	570	15	41,8	156,8
750	762	670	450	340	120	600	15	43,0	168,9
800	812,8	700	450	340	120	640	15	46,6	177,7
820	820	700	450	340	120	650	15	46,6	183,3

### MATERIAL GROUPS

MS No.	1	2	4	5	7	6	7
Tmax (°C)	350	500	400	500	350	620	350
Material	S235JR	16Mo3	1.4301	1.4571	P275NH	1.4948	P275NH

### DESIGN VERSIONS

Sliding surfaces (KP): S – steel, M – stainless steel mirror.

### PERMISSIBLE LOADS

Resultant external force must satisfy the following equation for total load:  $0.5 F_x/F_p + 1.5 \times F_y/F_p + F_z/F_p \leq 1$ , where  $F_x$  is a force in the direction of pipe axis and  $F_y$  is a horizontal force perpendicular to the pipe axis. The  $F_x$  and  $F_y$  components do not include the friction forces generated by vertical component  $F_z$ . The load-bearing capacity at higher temperatures and for different materials shall satisfy the following equation:  $F_{pt,M}^G = k_{t,M} \times F_p$ , where the correction factor is specified according to table 1.1.

## 21-1

Support with standard or optional height. The support height H can be specified in the interval  $0.5 \times H$  to  $1 \times H$ .

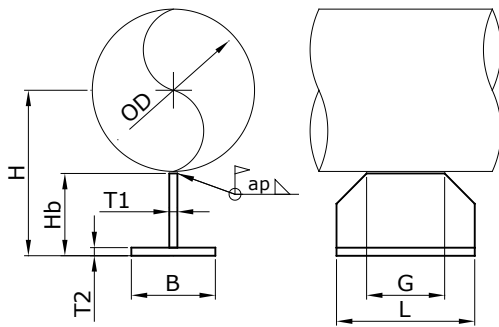

### DESIGNATION

#### 21-1 MS-DNK-H-KP

Example of designation: 21-14-073-170

DNK – pipe outer diameter code

H – required support height

MS – material group code

KP – sliding surface code

### ASSEMBLY

The support is welded to the pipe with a continuous fillet weld (fillet weld size ap).

### DIMENSIONS AND PARAMETERS

OD	DNK	H	B	L	Hb	ap	T1	T2	G	Fp	m
mm	mm	mm	mm	mm	mm	mm	mm	mm	mm	kN	kg
21,3	015	100	40	100	82	3	6	6	80	2,6	0,57
26,9	020	100	40	100	79	3	6	6	80	2,7	0,56
31,8	025	100	40	100	77	3	6	6	80	2,8	0,55
33,7	025	100	40	100	76	3	6	6	80	2,8	0,55
38	038	120	40	100	94	3	6	6	80	2,4	0,63
42,4	032	120	40	100	91	3	6	6	80	2,4	0,62
48,3	040	120	40	100	88	3	6	6	80	2,5	0,60
57	057	155	50	150	117	4	8	8	100	4,9	1,6
60,3	050	155	50	150	115	4	8	8	100	4,9	1,6
73	073	165	50	150	119	4	8	8	100	4,8	1,6
76,1	065	165	50	150	117	4	8	8	100	4,8	1,6
88,9	080	170	50	150	116	4	8	8	100	4,9	1,6
108	108	200	60	200	135	4	10	10	130	6,9	3,1
114,3	100	200	60	200	131	4	10	10	130	6,9	3,0
127	127	220	80	200	145	4	10	10	130	6,6	3,5
133	133	220	80	200	142	4	10	10	130	6,6	3,5
139,7	125	220	80	200	139	4	10	10	130	6,6	3,4
141,3	141	220	80	200	138	4	10	10	130	6,6	3,4
159	159	240	80	200	149	4	10	10	130	6,4	3,6
168,3	150	240	80	200	144	4	10	10	130	6,4	3,5

### MATERIAL GROUPS

MS No.	1	2	4	5	7	6	7
Tmax (°C)	350	500	400	500	350	620	350
Material	S235JR	16Mo3	1.4301	1.4571	P275NH	1.4948	P275NH

### DESIGN VERSIONS

Sliding surfaces (KP):

S – steel

T – PTFE plate with a diameter  $D_t = B - 5$  mm (see 2.10.)

### PERMISSIBLE LOADS

Resultant external force must satisfy the following equation for total load:  $F_x/F_p + 3.0 \times F_y/F_p + F_z/F_p \leq 1$ , where  $F_x$  is a force in the direction of pipe axis and  $F_y$  is a horizontal force perpendicular to the pipe axis. The  $F_x$  and  $F_y$  components do not include the friction forces generated by vertical component  $F_z$ . The load-bearing capacity at higher temperatures and for different materials shall satisfy the following equation:  $F_{pt,M}^G = k_{t,M} \times F_{pr}$  where the correction factor is specified according to table 1.1. =  $k_{t,M} \times F_{pr}$  where the correction factor is specified according to table 1.1.

## 21-2

Short, low support. Support height H cannot be changed.

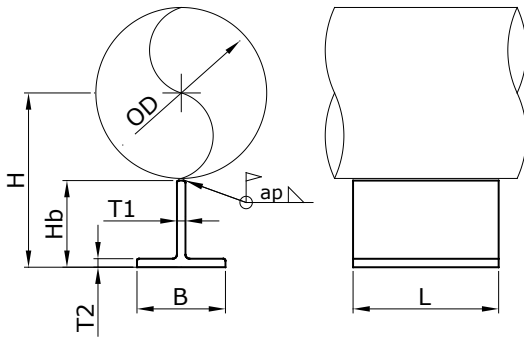

## DESIGNATION

## 21-2 MS-DNK-H-KP

Example of designation: 21-21-100-150

DNK – pipe outer diameter code

H – required support height

MS – material group code

KP – sliding surface code

## ASSEMBLY

The support is welded to the pipe with a continuous fillet weld (fillet weld size ap).

## DIMENSIONS AND PARAMETERS

OD	DNK	H	B	L	Hb	ap	T1	T2	Fp	m
mm	mm	mm	mm	mm	mm	mm	mm	mm	kN	kg
21,3	015	51	40	100	40	3	5	5	5,4	0,30
26,9	020	54	40	100	40	3	5	5	5,4	0,30
31,8	025	66	50	100	50	3	6	6	5,1	0,44
33,7	025	67	50	100	50	3	6	6	5,1	0,44
38	038	69	50	100	50	3	6	6	5,1	0,44
42,4	032	72	50	100	50	3	6	6	5,1	0,44
48,3	040	75	50	100	50	3	6	6	5,1	0,44
57	057	89	60	120	60	4	7	7	8,4	0,75
60,3	050	91	60	120	60	4	7	7	8,4	0,75
73	073	97	60	120	60	4	7	7	8,4	0,75
76,1	065	99	60	120	60	4	7	7	8,4	0,75
88,9	080	125	80	120	80	4	9	9	8,0	1,29
108	108	134	80	150	80	4	9	9	10,6	1,62
114,3	100	138	80	150	80	4	9	9	10,6	1,62
127	127	164	100	150	100	4	11	11	10,2	2,5
133	133	167	100	150	100	4	11	11	10,2	2,5
139,7	125	170	100	150	100	4	11	11	10,2	2,5
141,3	141	171	100	150	100	4	11	11	10,2	2,5
159	159	180	100	150	100	4	11	11	10,2	2,5
168,3	150	185	100	150	100	4	11	11	10,2	2,5

## MATERIAL GROUPS

MS No.	1	4	7
Tmax (°C)	350	400	350
Material	S235JR	1.4301	S235J2

## DESIGN VERSIONS

Sliding surfaces (KP):

S – steel

T – PTFE plate with a diameter Dt = B - 5 mm (see 2.10.)

## PERMISSIBLE LOADS

Resultant external force must satisfy the following equation for total load:  $F_x/F_p + 3.0 \times F_y/F_p + F_z/F_p \leq 1$ , where  $F_x$  is a force in the direction of pipe axis and  $F_y$  is a horizontal force perpendicular to the pipe axis. The  $F_x$  and  $F_y$  components do not include the friction forces generated by vertical component  $F_z$ . The load-bearing capacity at higher temperatures and for different materials shall satisfy the following equation:  $F_{pt,M}^G = k_{t,M} \times F_p$ , where the correction factor is specified according to table 1.1.

## 22-1

Support with standard or optional height. Support height H can be specified in the interval  $0.5 \times H$  to  $1 \times H$ . Also available in long version.

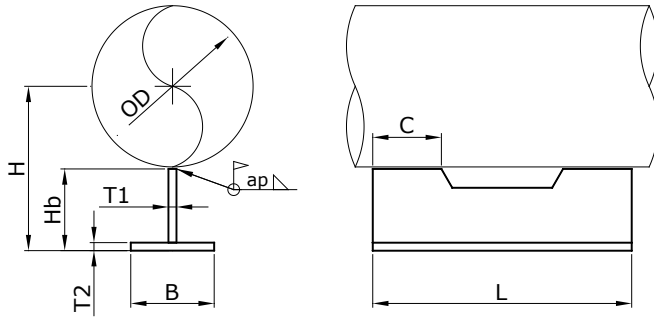

### DESIGNATION

#### 22-1(L) MS-DNK-H-KP

Example of designation: 22-14-108-220-M

DNK – pipe outer diameter code

H – required support height

MS – material group code

KP – sliding surface code

L – long version, the character is not normally specified

### ASSEMBLY

The support is welded to the pipe with a continuous fillet weld (fillet weld size ap).

### DIMENSIONS AND PARAMETERS

OD	DNK	H	B	L	Hb	ap	T1	T2	C	Fp	m
mm	mm	mm	mm	mm	mm	mm	mm	mm	mm	kN	kg
21,3	015	100	40	150	82	3	6	6	40	4,4	0,86
26,9	020	100	40	150	79	3	6	6	40	4,5	0,84
31,8	025	100	40	150	77	3	6	6	40	4,6	0,83
33,7	025	100	40	150	76	3	6	6	40	4,6	0,82
38	038	120	40	150	94	3	6	6	40	4,0	0,95
42,4	032	120	40	150	91	3	6	6	40	4,0	0,93
48,3	040	120	40	150	88	3	6	6	40	4,1	0,90
57	057	155	50	200	117	4	8	8	50	7,5	2,1
60,3	050	155	50	200	115	4	8	8	50	7,5	2,1
73	073	165	50	200	119	4	8	8	50	7,4	2,1
76,1	065	165	50	200	117	4	8	8	50	7,4	2,1
88,9	080	170	50	200	116	4	8	8	50	7,5	2,1
108	108	200	60	250	135	4	10	10	65	10,0	3,8
114,3	100	200	60	250	131	4	10	10	65	10,0	3,8
127	127	220	80	250	145	4	10	10	65	9,7	4,4
133	133	220	80	250	142	4	10	10	65	9,7	4,4
139,7	125	220	80	250	139	4	10	10	65	9,7	4,3
141,3	141	220	80	250	138	4	10	10	65	9,7	4,3
159	159	240	80	250	149	4	10	10	65	9,4	4,5
168,3	150	240	80	250	144	4	10	10	65	9,4	4,4

### MATERIAL GROUPS

MS No.	1	2	4	5	7	6	7
Tmax (°C)	350	500	400	500	350	620	350
Material	S235JR	16Mo3	1.4301	1.4571	P275NH	1.4948	P275NH

### DESIGN VERSIONS

Sliding surfaces (KP):

S – steel

T – PTFE plate with a diameter  $D_t = B - 5$  mm (see 2.10.)

Long version – the support length is 1.5 times longer than the standard length L.

Other dimensions remain unchanged; the weight is 1.5 times the tabular value of m.

### PERMISSIBLE LOADS

Resultant external force must satisfy the following equation for total load:  $F_x/F_p + 3.0 \times F_y/F_p + F_z/F_p \leq 1$ , where  $F_x$  is a force in the direction of pipe axis and  $F_y$  is a horizontal force perpendicular to the pipe axis. The  $F_x$  and  $F_y$  components do not include the friction forces generated by vertical component  $F_z$ . The load-bearing capacity at higher temperatures and for different materials shall satisfy the following equation:  $F_{pt,M}^G = k_{t,M} \times F_p$ , where the correction factor is specified according to table 1.1.

## 22-2

Low support. The height H cannot be changed. Also available in long version.

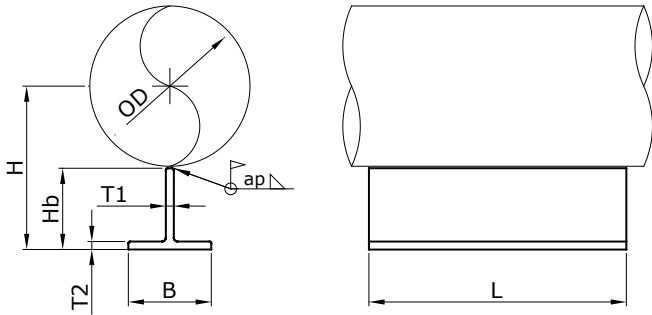

### DESIGNATION

#### 22-2(L) MS-DNK-H-KP

Example of designation: 22-2L1-050-91

DNK – pipe outer diameter code

H – support height

MS – material group code

KP – sliding surface code

L – long version, the character is not normally specified

### ASSEMBLY

The support is welded to the pipe with a continuous fillet weld (fillet weld size ap).

### DIMENSIONS AND PARAMETERS

OD	DNK	H	B	L	Hb	ap	T1	T2	Fp	m
mm	mm	mm	mm	mm	mm	mm	mm	mm	kN	kg
21,3	015	51	40	150	40	3	5	5	8,6	0,44
26,9	020	54	40	150	40	3	5	5	8,1	0,44
31,8	025	66	50	150	50	3	6	6	8,0	0,67
33,7	025	67	50	150	50	3	6	6	8,0	0,67
38	038	69	50	150	50	3	6	6	8,0	0,67
42,4	032	72	50	150	50	3	6	6	8,0	0,67
48,3	040	75	50	150	50	3	6	6	8,0	0,67
57	057	89	60	200	60	4	7	7	13,2	1,25
60,3	050	91	60	200	60	4	7	7	13,2	1,25
73	073	97	60	200	60	4	7	7	13,2	1,25
76,1	065	99	60	200	60	4	7	7	13,2	1,25
88,9	080	125	80	200	80	4	9	9	12,9	2,15
108	108	134	80	250	80	4	9	9	15,5	2,7
114,3	100	138	80	250	80	4	9	9	15,5	2,7
127	127	164	100	250	100	4	11	11	15,2	4,1
133	133	167	100	250	100	4	11	11	15,2	4,1
139,7	125	170	100	250	100	4	11	11	15,2	4,1
141,3	141	171	100	250	100	4	11	11	15,2	4,1
159	159	180	100	250	100	4	11	11	15,2	4,1
168,3	150	185	100	250	100	4	11	11	15,2	4,1

### MATERIAL GROUPS

MS No.	1	4	7
Tmax (°C)	350	400	350
Material	S235JR	1.4301	S235J2

### DESIGN VERSIONS

Sliding surfaces (KP):

S – steel

T – PTFE plate with a diameter Dt = B - 5 mm (see 2.10.)

Long version – the support length is 1.5 times longer than the standard length L. Other dimensions remain unchanged; the weight is 1.5 times the tabular value of m.

### PŘÍPUSTNÁ ZATÍŽENÍ

Resultant external force must satisfy the following equation for total load:  $F_x/F_p + 3.0 \times F_y/F_p + F_z/F_p \leq 1$ , where  $F_x$  is a force in the direction of pipe axis and  $F_y$  is a horizontal force perpendicular to the pipe axis. The  $F_x$  and  $F_y$  components do not include the friction forces generated by vertical component  $F_z$ . The load-bearing capacity at higher temperatures and for different materials shall satisfy the following equation:  $F_{pt,M}^G = k_{t,M} \times F_p$ , where the correction factor is specified according to table 1.1.

## 22-5

Standard adjustable support. Support height can be adjusted in the range of  $H_{min}$  to  $H_{max}$ . Also available in long version.

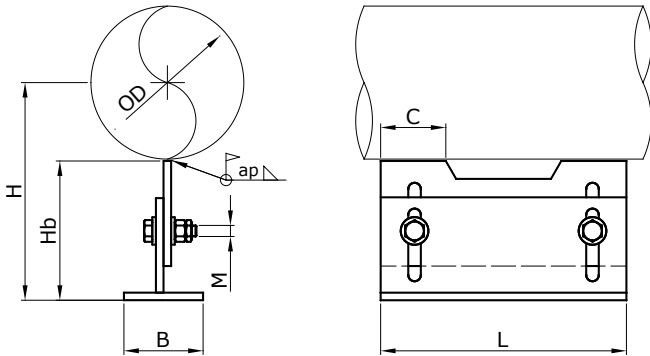

### DESIGNATION

#### 22-5(L) MS-DNK-H-KP

Example of designation: 22-51-032-120

DNK – pipe outer diameter code

H – required support height

MS – material group code

KP – sliding surface code

L – long version, the character is not normally specified

### ASSEMBLY

The support is welded to the pipe with a continuous fillet weld (fillet weld size  $ap$ ). Tightening torque for height adjustment bolts: M8-20 Nm, M10-40 Nm, M12-75 Nm.

### DIMENSIONS AND PARAMETERS

OD	DNK	H	Hmin	Hmax	B	L	Hb	ap	C	M	Fp	m
mm	mm	mm	mm	mm	mm	mm	mm	mm	mm	mm	kN	kg
21,3	015	100	75	125	40	150	82	3	40	8	4,4	0,99
26,9	020	100	75	130	40	150	79	3	40	8	4,5	0,97
31,8	025	100	80	130	40	150	77	3	40	8	4,6	0,95
33,7	025	100	80	135	40	150	76	3	40	8	4,6	0,94
38	038	120	80	135	40	150	94	3	40	8	4,0	1,09
42,4	032	120	85	140	40	150	91	3	40	8	4,0	1,06
48,3	040	120	90	135	40	150	88	3	40	10	4,1	1,04
57	057	155	115	200	50	200	117	4	50	10	7,5	2,4
60,3	050	155	115	200	50	200	115	4	50	10	7,5	2,4
73	073	165	120	205	50	200	119	4	50	10	7,4	2,4
76,1	065	165	125	210	50	200	117	4	50	10	7,4	2,4
88,9	080	170	130	205	50	200	116	4	50	12	7,5	2,4
108	108	200	150	250	60	250	135	4	65	12	10,0	4,4
114,3	100	200	155	250	60	250	131	4	65	12	10,0	4,3
127	127	220	160	260	80	250	145	4	65	12	9,7	5,1
133	133	220	165	260	80	250	142	4	65	12	9,7	5,0
139,7	125	220	165	265	80	250	139	4	65	12	9,7	4,9
141,3	141	220	170	265	80	250	138	4	65	12	9,7	4,9
159	159	240	175	275	80	250	149	4	65	12	9,4	5,2
168,3	150	240	180	280	80	250	144	4	65	12	9,4	5,1

### MATERIAL GROUPS

MS No.	1	2	4	5	7	6	7
Tmax (°C)	350	500	400	500	350	620	350
Material	S235JR	16Mo3	1.4301	1.4571	P275NH	1.4948	P275NH

### DESIGN VERSIONS

Sliding surfaces (KP):

S – steel

T – PTFE plate with a diameter  $Dt = B - 5$  mm (see 2.10.)

Long version – the support length is 1.5 times longer than the standard length L. Other dimensions remain unchanged; the weight is 1.5 times the tabular value of m.

### PERMISSIBLE LOADS

Resultant external force must satisfy the following equation for total load:  $F_x/F_p + 3.0 \times F_y/F_p + F_z/F_p \leq 1$ , where  $F_x$  is a force in the direction of pipe axis and  $F_y$  is a horizontal force perpendicular to the pipe axis. The  $F_x$  and  $F_y$  components do not include the friction forces generated by vertical component  $F_z$ . The load-bearing capacity at higher temperatures and for different materials shall satisfy the following equation:  $F_{pt,M}^G = k_{t,M} \times F_p$ , where the correction factor is specified according to table 1.1.

23-1

Short and low support for uninsulated pipes. The height H cannot be changed.

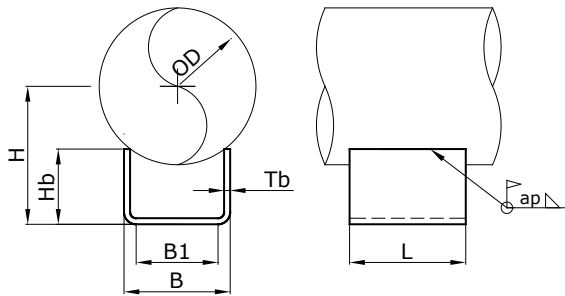

DESIGNATION

23-1 MS-DNK-KP

Example of designation: 23-11-080

DNK – pipe outer diameter code

MS – material group code

KP – sliding surface code

ASSEMBLY

The support is welded to the pipe with a continuous fillet weld (fillet weld size ap).

DIMENSIONS AND PARAMETERS

OD	DNK	H	B	L	Hb	ap	Tb	B1	Fp	m
mm	mm	mm	mm	mm	mm	mm	mm	mm	kN	kg
57	057	63	60	80	50	2,5	4	44	6,5	0,39
60,3	050	66	60	80	50	2,5	4	44	6,5	0,39
73	073	77	60	80	50	2,5	4	44	6,5	0,39
76,1	065	79	60	80	50	2,5	4	44	6,5	0,39
88,9	080	87	60	80	50	2,5	4	44	6,5	0,39
108	108	101	80	100	60	4	4	64	11,4	0,62
114,3	100	105	80	100	60	4	4	64	11,4	0,62
127	127	113	80	100	60	4	4	64	11,4	0,62
133	133	117	80	100	60	4	4	64	11,4	0,62
139,7	125	121	80	100	60	4	4	64	11,4	0,62
141,3	141	122	80	100	60	4	4	64	11,4	0,62
159	159	118	120	100	60	4	5	100	11,4	0,92
168,3	150	125	120	100	60	4	5	100	11,4	0,92
193,7	175	141	120	100	60	4	5	100	11,4	0,92
219,1	200	156	120	100	60	4	5	100	11,4	0,92
244,5	225	170	120	120	60	4	5	100	14,1	1,11
273	250	196	160	120	80	4	6	136	13,8	1,77
323,9	300	225	160	120	80	4	6	136	13,8	1,77
355,6	350	243	160	120	80	5	6	136	15,9	1,77
377	377	254	160	120	80	5	6	136	15,9	1,77
406,4	400	278	210	140	100	5	6	186	15,8	2,7
426	426	290	210	140	100	5	6	186	15,8	2,7
457	450	307	210	140	100	5	6	186	15,8	2,7
508	500	312	300	140	100	5	8	260	22,2	4,3
530	530	325	300	140	100	5	8	260	22,2	4,3
559	550	342	300	180	100	5	8	260	29,7	5,6
609,6	600	376	350	180	120	5	8	310	39,5	6,6
630	630	388	350	180	120	5	8	310	39,5	6,6
664	650	406	350	180	120	5	8	310	29,9	6,6
711,2	700	410	430	180	120	5	8	390	29,9	7,5
720	720	416	430	180	120	5	8	390	29,9	7,5
762	750	441	430	180	120	5	8	390	29,9	7,5
812,8	800	471	430	180	120	5	8	390	29,9	7,5
820	820	475	430	180	120	5	8	390	29,9	7,5

MATERIAL GROUPS

MS No.	1	4
Tmax (°C)	350	400
Material	S235JR	1.4301

DESIGN VERSIONS

Sliding surfaces (KP):

S – steel

M – stainless steel mirror

T – PTFE plate with a diameter Dt=B-5 mm (see 2.10.)

PERMISSIBLE LOADS

Resultant external force must satisfy the following equation for total load:  $F_x/F_p + F_y/F_p + F_z/F_p \leq 1$ , where  $F_x$  is a force in the direction of pipe axis and  $F_y$  is a horizontal force perpendicular to the pipe axis. The  $F_x$  and  $F_y$  components do not include the friction forces generated by vertical component  $F_z$ . The load-bearing capacity at higher temperatures and for different materials shall satisfy the following equation:  $F_{pt,M}^G = k_{t,M} \times F_p$ , where the correction factor is specified according to table 1.1.



## 25-1

Support with standard or optional height. Support height H can be specified in the interval  $0.5 \times H$  to  $1.2 \times H$ .

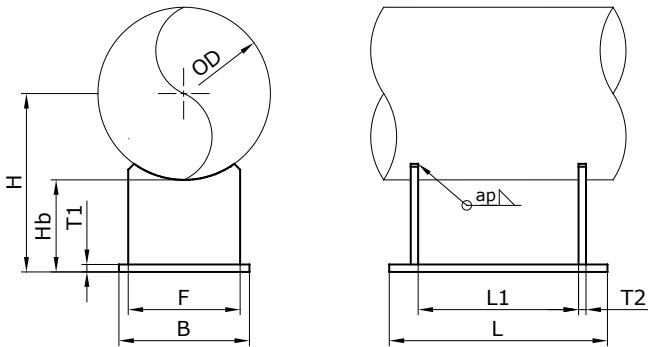

### DESIGNATION

#### 25-1 MS-DNK-H-KP

Example of designation: 25-12-100-220

DNK – pipe outer diameter code, H – required support height, MS – material group code, KP – sliding surface code, L – long design, no character is normally specified.

### ASSEMBLY

The support is welded to the pipe with a continuous fillet weld (fillet weld size ap).

### DIMENSIONS AND PARAMETERS

OD	DNK	H	B	L	Hb	ap	T1	T2	F	L1	Fp	m
mm	mm	mm	mm	mm	mm	mm	mm	mm	mm	mm	kN	kg
57	057	155	80	200	127	3	8	6	50	134	4,4	1,60
60,3	050	155	80	200	125	3	8	6	50	134	4,4	1,59
73	073	165	85	200	129	3	8	6	60	134	5,3	1,79
76,1	065	165	85	200	127	3	8	6	60	134	5,3	1,79
88,9	080	170	85	200	126	3	8	6	60	134	5,4	1,78
108	108	200	100	240	146	4	10	8	80	162	7,9	3,4
114,3	100	200	100	240	143	4	10	8	80	162	7,9	3,3
127	127	220	120	240	157	4	10	8	100	162	9,5	4,2
133	133	220	120	240	154	4	10	8	100	162	9,5	4,2
139,7	125	220	120	240	150	4	10	8	100	162	9,5	4,1
141,3	141	220	120	240	149	4	10	8	100	162	9,5	4,1
159	159	240	120	240	161	4	10	8	100	162	9,5	4,3
168,3	150	240	120	240	156	4	10	8	100	162	9,5	4,2
193,7	175	270	140	240	173	4	10	8	120	162	11,1	5,2
219,1	200	290	150	240	180	4	10	8	130	162	11,9	5,8
244,5	225	300	150	240	178	5	12	10	130	150	17,1	7,0
273	250	330	165	300	194	5	12	10	145	210	15,7	9,1
323,9	300	380	190	300	218	5	12	10	170	210	18,0	11,2
355,6	350	400	200	300	222	5	12	10	180	210	19,0	11,9
377	377	400	200	300	212	5	12	10	180	210	19,0	11,6
406,4	400	430	205	350	227	6	15	12	185	248	26,1	16,4
426	426	430	205	350	217	6	15	12	185	248	26,1	16,0
457	450	470	225	350	242	6	15	12	200	248	28,6	18,4
508	500	500	230	350	246	6	15	12	210	248	29,2	19,2
530	530	500	230	350	235	6	15	12	210	248	29,2	18,8
559	550	530	240	350	251	6	15	12	220	228	30,5	20
609,6	600	560	255	450	255	6	15	12	225	328	25,2	24
630	630	560	255	450	245	6	15	12	225	328	25,2	24
664	650	590	270	450	260	6	20	15	240	325	38,8	34
711,2	700	630	290	450	275	6	20	15	260	325	46,7	37
720	720	630	320	450	270	6	20	15	290	325	46,7	41
762	750	670	340	450	289	6	20	15	310	325	49,2	45
812,8	800	700	340	450	294	6	20	15	310	325	48,9	45
820	820	700	340	450	290	6	20	15	310	325	48,9	45

### MATERIAL GROUPS

MS No.	1	2	4	5	7
Tmax (°C)	350	500	400	500	350
Material	S235JR	16Mo3	1.4301	1.4571	P275NH

### DESIGN VERSIONS

Sliding surfaces (KP): S – steel, M – stainless steel mirror, T – PTFE plate with the diameter of  $Dt = B - 5$  mm (see 2.10.)

### PERMISSIBLE LOADS

Resultant external force must satisfy the following equation for total load:  $F_x/F_p + F_y/F_p + F_z/F_p \leq 1$ , where  $F_x$  is a force in the direction of pipe axis and  $F_y$  is a horizontal force perpendicular to the pipe axis. The  $F_x$  and  $F_y$  components do not include the friction forces generated by vertical component  $F_z$ . The load-bearing capacity at higher temperatures and for different materials shall satisfy the following equation:  $F_{pt,M}^G = k_{t,M} \times F_{p'}^G$  where the correction factor is specified according to table 1.1.

25-2

Support with standard or optional height. Support height H can be specified in the interval  $0.5 \times H$  to  $1.2 \times H$ .

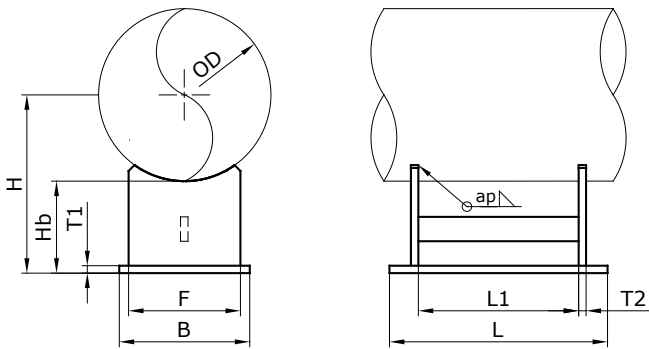

DESIGNATION

25-2 MS-DNK-H-KP

Example of designation: 25-27-530-500-T

DNK – pipe outer diameter code, H – required support height, MS – material group code, KP – sliding surface code, L – long design, no character is normally specified.  
 DNK – pipe outer diameter code, MS – material group code, KP – sliding surface code

ASSEMBLY

The support is welded to the pipe with a continuous fillet weld (fillet weld size ap).

DIMENSIONS AND PARAMETERS

OD	DNK	H	B	L	Hb	ap	T1	T2	F	L1	Fp	m
mm	mm	mm	mm	mm	mm	mm	mm	mm	mm	mm	kN	kg
57	057	155	80	200	127	3	8	6	50	134	7,5	1,79
60,3	050	155	80	200	125	3	8	6	50	134	7,5	1,78
73	073	165	85	200	129	3	8	6	60	134	9,4	1,98
76,1	065	165	85	200	127	3	8	6	60	134	9,4	1,97
88,9	080	170	85	200	126	3	8	6	60	134	9,5	1,97
108	108	200	100	240	146	4	10	8	80	162	12,9	3,4
114,3	100	200	100	240	143	4	10	8	80	162	12,9	3,7
127	127	220	120	240	157	4	10	8	100	162	15,4	4,6
133	133	220	120	240	154	4	10	8	100	162	15,4	4,6
139,7	125	220	120	240	150	4	10	8	100	162	15,4	4,6
141,3	141	220	120	240	149	4	10	8	100	162	15,4	4,5
159	159	240	120	240	161	4	10	8	100	162	15,4	4,8
168,3	150	240	120	240	156	4	10	8	100	162	15,4	4,7
193,7	175	270	140	240	173	4	10	8	120	162	18,0	5,8
219,1	200	290	150	240	180	4	10	8	130	162	19,3	6,3
244,5	225	300	150	240	178	5	12	10	130	150	27,8	7,6
273	250	330	165	300	194	5	12	10	145	210	21,5	10,1
323,9	300	380	190	300	218	5	12	10	170	210	24,8	12,2
355,6	350	400	200	300	222	5	12	10	180	210	26,1	12,9
377	377	400	200	300	212	5	12	10	180	210	26,1	12,6
406,4	400	430	205	350	227	6	15	12	185	248	32,1	17,8
426	426	430	205	350	217	6	15	12	185	248	32,1	17,4
457	450	470	225	350	242	6	15	12	200	248	35,2	19,8
508	500	500	230	350	246	6	15	12	210	248	36,0	21
530	530	500	230	350	235	6	15	12	210	248	36,0	21
559	550	530	240	350	251	6	15	12	220	228	37,5	22
609,6	600	560	255	450	255	6	15	12	225	328	27,0	27
630	630	560	255	450	245	6	15	12	225	328	27,0	26
664	650	590	270	450	260	6	20	15	240	325	50,8	37
711,2	700	630	290	450	275	6	20	15	260	325	60,2	41
720	720	630	320	450	270	6	20	15	290	325	60,2	45
762	750	670	340	450	289	6	20	15	310	325	64,0	49
812,8	800	700	340	450	294	6	20	15	310	325	64,0	49
820	820	700	340	450	290	6	20	15	310	325	64,0	49

MATERIAL GROUPS

MS No.	1	2	4	5	7
Tmax (°C)	350	500	400	500	350
Material	S235JR	16Mo3	1.4301	1.4571	P275NH

DESIGN VERSIONS

Sliding surfaces (KP): S – steel, M – stainless steel mirror, T – PTFE plate with Dt = B - 5 mm (see 2.10).

PERMISSIBLE LOADS

Resultant external force must satisfy the following equation for total load:  $F_x/F_p + F_y/F_p + F_z/F_p \leq 1$ , where  $F_x$  is a force in the direction of pipe axis and  $F_y$  is a horizontal force perpendicular to the pipe axis. The  $F_x$  and  $F_y$  components do not include the friction forces generated by vertical component  $F_z$ . The load-bearing capacity at higher temperatures and for different materials shall satisfy the following equation:  $F_{pt,M}^G = k_{t,M} \times F_p$  where the correction factor is specified according to table 1.1.

## 25-7

Standard adjustable support. The height of the support can be adjusted in the range of  $H_{min}$  to  $H_{max}$ .

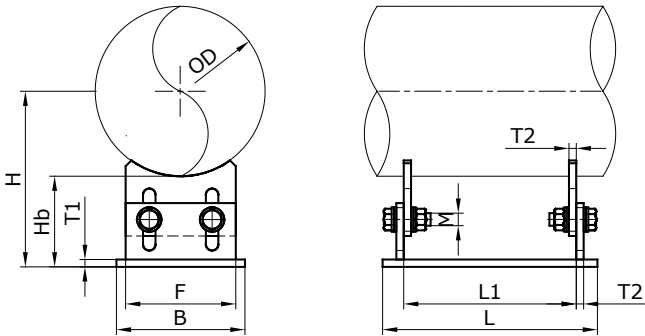

## DESIGNATION

## 25-7 MS-DNK-H-KP-(L)

Example of designation: 25-75-100-220-T

DNK – pipe outer diameter code, H – required support height, MS – material group code, KP – sliding surface code, L – long design, no character is normally specified.

DNK – pipe outer diameter code, MS – material group code, KP – sliding surface code

## ASSEMBLY

The support is welded to the pipe with a continuous fillet weld (fillet weld size ap).

## DIMENSIONS AND PARAMETERS

OD	DNK	H	Hmin	Hmax	B	L	Hb	F	T1	T2	M	L1	Fp	m
mm	mm	mm	mm	mm	mm	mm	mm	mm	mm	mm	mm	mm	kN	kg
57	057	155	138	172	80	200	127	50	8	6	10	134	4,4	1,75
60,3	050	155	138	172	80	200	125	50	8	6	10	134	4,4	1,74
73	073	165	147	183	85	200	129	60	8	6	10	134	5,3	1,98
76,1	065	165	148	182	85	200	127	60	8	6	10	134	5,3	1,96
88,9	080	170	155	185	85	200	126	60	8	6	12	134	5,4	1,95
108	108	200	182	218	100	240	146	80	12	8	12	162	7,9	3,7
114,3	100	200	183	217	100	240	143	80	12	8	12	162	7,9	3,7
127	127	220	199	241	120	240	157	100	12	8	12	162	9,5	4,7
133	133	220	200	240	120	240	154	100	12	8	12	162	9,5	4,7
139,7	125	220	201	239	120	240	150	100	12	8	12	162	9,5	4,6
141,3	141	220	201	239	120	240	149	100	12	8	12	162	9,5	4,6
159	159	240	218	262	120	240	161	100	12	8	12	162	9,5	4,8
168,3	150	240	220	260	120	240	156	100	12	8	12	162	9,5	4,7
193,7	175	270	249	291	140	240	173	120	12	8	16	162	11,1	5,9
219,1	200	290	267	313	150	240	180	130	12	8	16	162	11,9	6,5
244,5	225	300	280	320	150	240	178	130	15	10	16	150	17,1	7,9
273	250	330	306	354	165	300	194	145	15	10	16	210	15,7	10,2
323,9	300	380	349	411	190	300	218	170	15	10	16	210	18,0	12,6
355,6	350	400	368	432	200	300	222	180	15	10	16	210	19,0	13,5
377	377	400	371	429	200	300	212	180	15	10	16	210	19,0	13,1
406,4	400	430	404	456	205	350	227	185	20	12	20	248	26,1	18,3
426	426	430	406	454	205	350	217	185	20	12	20	248	26,1	17,9
457	450	470	440	500	225	350	242	200	20	12	20	248	28,6	21
508	500	500	469	531	230	350	246	210	20	12	20	248	29,2	22
530	530	500	472	528	230	350	235	210	20	12	20	248	29,2	21
559	550	530	498	562	240	350	251	220	20	12	20	228	30,5	23
609,6	600	560	531	589	255	450	255	225	20	12	24	328	25,2	27
630	630	560	533	587	255	450	245	225	20	12	24	328	25,2	26
664	650	590	559	621	270	450	260	240	20	15	24	325	38,8	37
711,2	700	630	596	664	290	450	275	260	20	15	24	325	46,7	41
720	720	630	597	663	320	450	270	290	20	15	24	325	46,7	46
762	750	670	632	708	340	450	289	310	20	15	24	325	49,2	50
812,8	800	700	661	739	340	450	294	310	20	15	24	325	48,9	51
820	820	700	662	738	340	450	290	310	20	15	24	325	48,9	50

## MATERIAL GROUPS

MS No.	1	2	4	5	7
Tmax (°C)	350	500	400	500	350
Material	S235JR	16Mo3	1.4301	1.4571	P275NH

## DESIGN VERSIONS

Sliding surfaces (KP): S – steel, M – stainless steel mirror, T – PTFE plate with diameter  $Dt = B - 5$  mm (see 2.10.)

## PERMISSIBLE LOADS

Resultant external force must satisfy the following equation for total load:  $F_x/F_p + F_y/F_p + F_z/F_p \leq 1$ , where  $F_x$  is a force in the direction of pipe axis and  $F_y$  is a horizontal force perpendicular to the pipe axis. The  $F_x$  and  $F_y$  components do not include the friction forces generated by vertical component  $F_z$ . The load-bearing capacity at higher temperatures and for different materials shall satisfy the following equation:  $F_{pt,M}^G = k_{t,M} \times F_p$ , where the correction factor is specified according to table 1.1.

## 26-2

Adjustable trunnion support for horizontal pipes. The height adjustment range, with respect to the specified  $H_{nom}$  dimension, is +/- 50 mm for DN200–DN350 and +/- 100 mm for DN > 350. The required nominal height H can be adjusted within +100 mm of the value  $H_{nom}$  given in the table. The support can be used as a sliding support, an anchor (welded base) or a guide, where guide elements are added to the base.

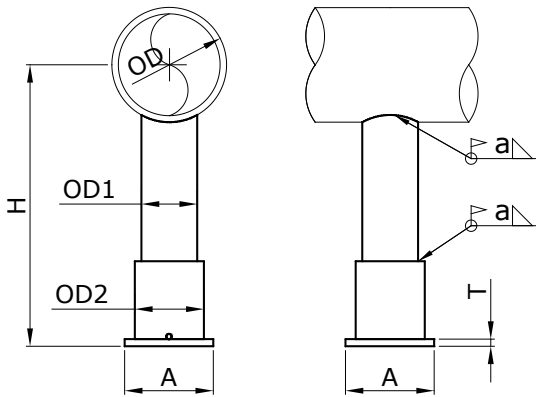

### DESIGNATION

#### 26-2 MS-DNK-H-KP

Example of designation: 26-21-700-910-M

DNK – pipe outer diameter code

H – required support height

MS – material group code

KP – sliding surface code

### ASSEMBLY

The support is welded to the pipe with a continuous fillet weld (fillet weld size a).

### DIMENSIONS AND PARAMETERS

DNK	OD	A	H <sub>nom</sub>	OD1	OD2	T	a	F <sub>p</sub>	m
mm	mm	mm	mm	mm	mm	mm	mm	kN	kg
200	219,1	200	460	127	140	10	3	15	9
225	244,5	200	475	127	140	10	3	15	9
250	273	200	485	127	140	10	3	15	9
300	323,9	250	510	159	168	12	4	27	13
300	325	250	510	159	168	12	4	27	13
350	351	250	525	159	168	12	4	27	13
350	355,6	250	525	159	168	12	4	27	13
350	377	250	540	159	168	12	4	27	13
400	406,4	300	750	194	219	15	5	40	31
400	426	300	760	194	219	15	5	40	31
450	465	300	780	194	219	15	5	40	31
500	508	300	805	194	219	15	5	40	31
500	530	300	815	194	219	15	5	40	31
550	559	300	830	194	219	15	5	40	31
600	609,6	400	855	219	245	20	6	50	48
600	630	400	865	219	245	20	6	50	48
700	711	450	905	324	356	20	6	100	72
700	720	450	910	324	356	20	6	100	72
750	762	450	930	324	356	20	6	100	72
800	813	450	955	324	356	20	6	100	72
800	820	450	960	324	356	20	6	100	72

### MATERIAL GROUPS

MS No.	1	4	7
Tmax (°C)	350	350	350
Material	P235GH	1.4301	P275NH

### DESIGN VERSIONS

Sliding surfaces (KP):

S – steel

M – stainless steel mirror

T – PTFE plate with diameter Dt = A - 50 mm (see 2.10.)

### PERMISSIBLE LOADS

Resultant external force must satisfy the following equation for total load:  $3 \times F_x/F_p + 3 \times F_y/F_p + F_z/F_p \leq 1$ , where  $F_x$  is a force in the direction of pipe axis and  $F_y$  is a horizontal force perpendicular to the pipe axis. The  $F_x$  and  $F_y$  components do not include the friction forces generated by vertical component  $F_z$ . The load-bearing capacity at higher temperatures and for different materials shall satisfy the following equation:  $F_{pt,M}^G = k_{t,M} \times F_p$ , where the correction factor is specified according to table 1.1.

## 26-3

Adjustable elbow trunnion support for elbows with radius  $R = 1,5 \times D$ . The height adjustment range, with respect to the specified  $H_{nom}$  dimension, is  $\pm 50$  mm for DN200–DN350 and  $\pm 100$  mm for DN>350. The required nominal height  $H$  can be adjusted within  $\pm 100$  mm of the value  $H_{nom}$  given in the table. The support can be used as a sliding support, an anchor (welded base) or a guide, where guide elements are added to the base.

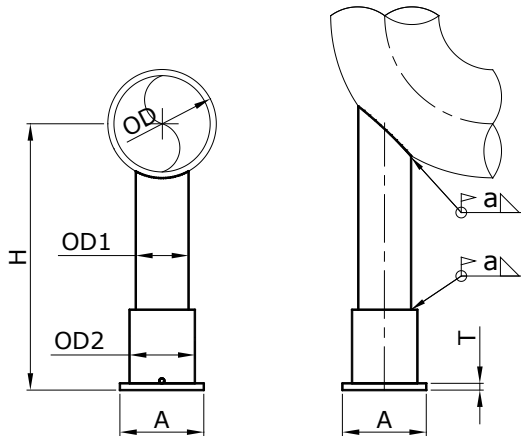

### DESIGNATION

#### 26-3 MS-DNK-H-KP

Example of designation: 26-34-250-485

DNK – pipe outer diameter code

H – required support height

MS – material group code

KP – sliding surface code

### ASSEMBLY

The support is welded to the pipe with a continuous fillet weld (fillet weld size  $a$ ).

### DESIGN VERSIONS

Sliding surfaces (KP): S – steel, M – stainless steel mirror, T – PTFE plate with the diameter of  $D_t = A - 50$  mm (see 2.10.)

### DIMENSIONS AND PARAMETERS

DNK	OD	A	H <sub>nom</sub>	OD1	OD2	T	a	F <sub>p</sub>	m
mm	mm	mm	mm	mm	mm	mm	mm	kN	kg
100	108	130	360	76	89	8	3	8	3,6
100	114,3	130	360	76	89	8	3	8	3,6
125	127	130	365	76	89	8	3	8	3,6
125	133	130	365	76	89	8	3	8	3,6
125	139,7	130	365	76	89	8	3	8	3,6
125	141,3	130	365	76	89	8	3	8	3,6
150	159	160	380	114	127	8	3	16	5,5
150	168,3	160	380	114	127	8	3	16	5,5
175	193,7	160	420	114	127	8	3	15	5,8
200	219,1	200	460	127	140	10	3	17	9
225	244,5	200	475	127	140	10	3	16	9
250	273	200	485	127	140	10	3	16	9
300	323,9	250	510	159	168	12	4	30	13
300	325	250	510	159	168	12	4	30	13
350	351	250	525	159	168	12	4	29	13
350	355,6	250	525	159	168	12	4	29	13
350	377	250	540	159	168	12	4	29	13
400	406,4	300	750	194	219	15	5	41	31
400	426	300	760	194	219	15	5	40	31
450	465	300	780	194	219	15	6	48	31
500	508	300	805	194	219	15	6	47	31
500	530	300	815	194	219	15	6	46	31
550	559	300	830	194	219	15	6	46	31
600	609,6	400	855	219	245	20	6	56	48
600	630	400	865	219	245	20	6	55	48
700	711	450	905	324	356	20	6	100	72
700	720	450	910	324	356	20	6	100	72
750	762	450	930	324	356	20	6	100	72

### MATERIAL GROUPS

MS No.	1	4	7
Tmax (°C)	350	350	350
Material	P235GH	1.4301	P275NH

### PERMISSIBLE LOADS

Resultant external force must satisfy the following equation for total load:  $3 \times F_x/F_p + 3 \times F_y/F_p + F_z/F_p \leq 1$ , where  $F_x$  is a force in the direction of pipe axis and  $F_y$  is a horizontal force perpendicular to the pipe axis. The  $F_x$  and  $F_y$  components do not include the friction forces generated by vertical component  $F_z$ . The load-bearing capacity at higher temperatures and for different materials shall satisfy the following equation:  $F_{pt,M}^G = k_{t,M} \times F_p$ , where the correction factor is specified according to table 1.1.

## 29-2

Welding bracket for vertical pipes, it can be used as a sliding support, as a guide, or it can be placed on a pair of spring supports. On request, the brackets can be supplied with dimension E modified by +/- 20 % from the nominal value listed in the table.

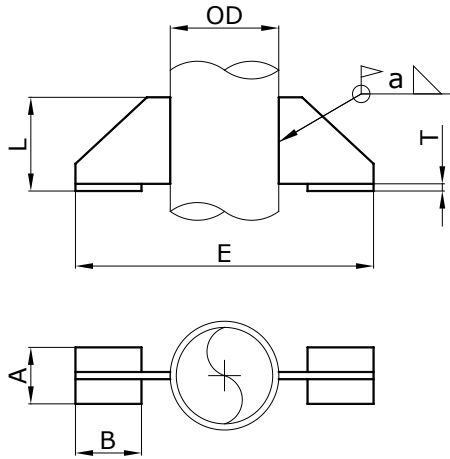

### DESIGNATION

#### 29-2 MS-DNK-E-KP

Example of designation: 29-21-040-285

DNK – pipe outer diameter code

E – required foot spacing

MS – material group code

KP – sliding surface code

### ASSEMBLY

The bracket is welded to the pipe with a continuous fillet weld (fillet weld size a).

### DIMENSIONS AND PARAMETERS

DNK	OD	A	B	L	E	T	a	Fp	m
mm	mm	mm	mm	mm	mm	mm	mm	kN	kg
15	21,3	30	50	65	200	5	2,5	2,8	0,4
20	26,9	30	50	65	200	5	2,5	2,9	0,4
25	33,7	30	50	65	250	5	2,5	2,2	0,6
38	38	40	50	66	250	5	2,5	2,2	0,6
32	42,4	40	50	66	250	5	2,5	2,3	0,6
40	48,3	40	50	66	250	5	2,5	2,5	0,8
57	57	50	50	87	250	6	2,5	6,0	0,8
50	60,3	50	50	87	250	6	2,5	6,1	0,8
73	73	50	60	87	300	6	3	5,7	1
65	76,1	50	60	87	300	6	3	5,7	1
80	88,9	60	60	90	300	6	3	6,3	1
108	108	80	60	112	370	8	3	9,1	3
100	114,3	80	60	112	370	8	3	9,3	3

### MATERIAL GROUPS

MS No.	1	4	7
Tmax (°C)	350	350	350
Material	P235GH	1.4301	P275NH

### PERMISSIBLE LOADS

The load-bearing capacity at higher temperatures and for different materials shall satisfy the following equation:  $F_{pt,M}^G = k_{t,M} \times F_{pr}$  where the correction factor is specified according to table 1.1.

### DESIGN VERSIONS

Sliding surfaces (KP):

S – steel

## 29-3

Welding bracket for vertical pipes, it can be used as a sliding support, as a guide, or it can be placed on a pair of spring supports. On request, the brackets can be supplied with dimension E modified by +/-20 % from the nominal value listed in the table.

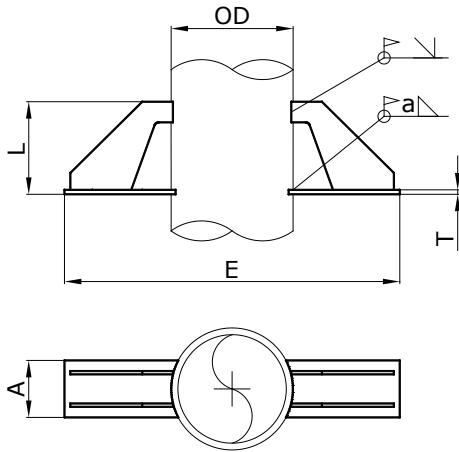

### DESIGNATION

#### 29-3 MS-DNK-E-KP

Example of designation: 29-37-159-659

DNK – pipe outer diameter code

E – required foot spacing

MS – material group code

KP – sliding surface code

### ASSEMBLY

The bottom plate of the support bracket is welded to the pipe with a continuous fillet weld (fillet weld size a), the web is welded with a V-weld.

### DIMENSIONS AND PARAMETERS

DNK	OD	A	L	E	T	a	m	Fp
mm	mm	mm	mm	mm	mm	mm	kg	kN
125	133	100	128	583	8	2,5	5,5	17,5
125	139,7	100	128	590	8	2,5	5,5	17,5
150	159	110	128	659	8	2,5	6,5	18,8
150	168,3	115	128	668	8	2,5	6,6	20,3
175	193,7	125	160	694	8	3	9,9	29,2
200	219,1	140	160	779	8	3	11,8	32,1
250	273	150	160	833	8	3	12,2	36,0
300	323,9	160	190	924	8	3	14,7	39,1
300	325	170	190	925	8	3	15,2	43,3
350	355,6	180	202	956	8	4	19,7	64,3
377	377	180	202	977	8	4	19,7	64,3
400	406,4	190	212	1056	10	4	22,5	66,3
400	426	190	212	1076	10	4	22,5	66,3
500	508	200	235	1158	10	4	29,7	73,6
500	530	200	235	1230	10	4	32,0	69,1
630	630	220	255	1330	10	4	34,9	82,3
720	711	250	255	1420	15	4	37,4	101
820	813	280	255	1520	15	4	39,9	122

### MATERIAL GROUPS

MS No.	1	4	7
Tmax (°C)	350	350	350
Material	P235GH	1.4301	P275NH

### PERMISSIBLE LOADS

The load-bearing capacity at higher temperatures and for different materials shall satisfy the following equation:  $F_{pt,M}^G = k_{t,M} \times F_p$ , where the correction factor is specified according to table 1.1.

### DESIGN VERSIONS

Sliding surfaces (KP):

S – steel

2

# GUIDES



## 2.1. USE

The guides are intended for these types of restraints:

Name	Symbol	Description, function	Types of
Guide in one direction	SG-2	Support with two pipe shoes. It limits movements and transfers forces in a direction perpendicular to pipe axis. Minimum specified gap is +/- 2 mm. Friction force acts in the direction of pipe axis.	31, 32, 35, 36
Resting support with guide	SG-3	Pipe support with one pipe shoe in vertical direction, and two pipe shoes in horizontal direction. It limits movements and transfers forces in a direction perpendicular to pipe axis. Minimum specified gap is +/- 2 mm. Friction forces act in the direction of pipe axis.	33, 37
Guide in two directions	SG-4	Support with four pipe shoes. It limits movements and transfers forces in both directions perpendicular to pipe axis. Minimum specified gap is min. +/-2 mm. Friction forces act in the direction of pipe axis.	34, 36 +pom. konstr.*

\* In cases where it is not possible to use support type 34, a double-pipe-shoe guide of type 36 is used for two-directional guides (usually vertical pipes). It is supplemented with four stops (guiding elements) that limit movement in the axis perpendicular to axis of the pipe shoes. The guides of types 31 and 32 cannot be used to restrain movement in the direction perpendicular to the plane formed by the pipe shoes!

Example:

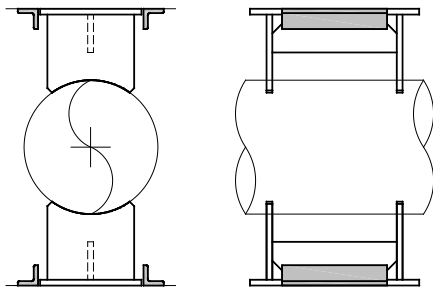

The axis the pipe shoes must always point in the direction of a higher load.

## 2.2. TYPE OF PIPE CONNECTION ELEMENTS

In terms of pipe connection elements, there are two types of supports:

- Clamped (C)
- Welding (W)

The use and selection criteria are described in chapter 1.2. – Supports.

## 2.3. SLIDE SURFACES

The design of slide surfaces of guides is identical to supports. The characteristics, use and selection criteria are described in chapters 1.3. and 1.11. – Supports.

## 2.4. GUIDE DESIGN AND CHARACTERISTICS

The design of guides is similar to supports. The basic characteristics, use, load-bearing capacity and selection criteria are described in chapters 1.4. to 1.10. – Supports.

When selecting a restraint type, special attention must be paid to gaps between the pipe shoes and auxiliary structure. The pipe shoes (as well as the pipe diameter) expand radially when heated, and when the gap is used up and the pipe shoes come in contact with the auxiliary structure, the movement in the direction of pipe axis may be blocked. Therefore, a gap for pipes with operating temperatures above 100 °C must be selected so that the possibility of a support being locked is avoided. When guides are used to provide seismic resistance of the piping, it must be considered that gaps differ in cold and hot conditions.

The guides for vertical pipes with a nominal diameter of  $DN \geq 100$  mm, must be secured with shear lugs against axial slipping from both sides – upper and lower. Two or four flat shear lugs are welded on to the pipe.

## 31-3

Short double-pipe-shoe guide with standard or optional height. Pipe shoe height H can be specified in the interval  $0.5 \times H$  to  $1 \times H$ .

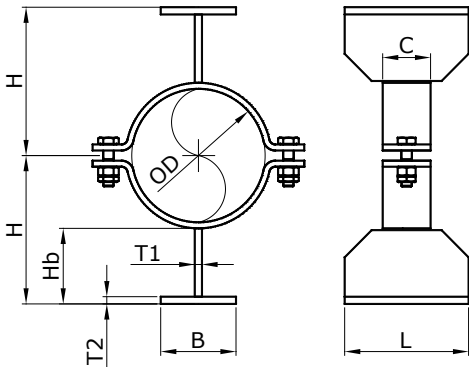

## DESIGNATION

## 31-3 MS-DNK-H-KP

Example of designation: 31-31-065-165

DNK – pipe outer diameter code  
 H – required height of the pipe shoe  
 MS – material group code  
 KP – sliding surface code

## ASSEMBLY

The clamp bolts are to be hand-tightened until the clamp is in full contact with the pipe and then the bolts are to be tightened by further  $180^\circ$  using a wrench.

## DIMENSIONS AND PARAMETERS

OD	DNK	H	B	L	C	Hb	T1	T2	Fp	m
mm	Mm	mm	mm	mm	mm	mm	mm	mm	kN	kg
21,3	015	100	40	100	30	82	6	6	1,1	1,46
26,9	020	100	40	100	30	79	6	6	1,1	1,45
31,8	025	100	40	100	30	77	6	6	1,2	1,45
33,7	025	100	40	100	30	76	6	6	1,2	1,45
38	038	120	40	100	30	94	6	6	1,0	1,63
42,4	032	120	40	100	30	91	6	6	1,0	1,62
48,3	040	120	40	100	30	88	6	6	1,0	1,62
57	057	155	50	150	40	117	8	8	1,9	3,3
60,3	050	155	50	150	40	115	8	8	1,9	3,3
73	073	165	50	150	40	119	8	8	1,8	3,4
76,1	065	165	50	150	40	117	8	8	1,8	3,4
88,9	080	170	50	150	40	116	8	8	1,8	3,5
108	108	200	60	200	50	135	10	10	2,5	6,2
114,3	100	200	60	200	50	131	10	10	2,5	6,2
127	127	220	80	200	50	145	10	10	2,4	7,1
133	133	220	80	200	50	142	10	10	2,4	7,1
139,7	125	220	80	200	50	139	10	10	2,4	7,1
141,3	141	220	80	200	50	138	10	10	2,4	7,1
159	159	240	80	200	50	149	10	10	2,3	7,5
168,3	150	240	80	200	50	144	10	10	2,3	7,5

## MATERIAL GROUPS

MS No.	1	2	3	4	5	6	7
Tmax (°C)	350	500	580	400	500	620	350
Material	S235JR	16Mo3	10CrMo910	1.4301	1.4571	1.4948	P275NH

## PERMISSIBLE LOADS

The load-bearing capacity at higher temperatures and for different materials shall satisfy the following equation:  
 $F_{pt,M}^G = k_{t,M} \times F_{pr}$  where the correction factor is specified according to table 1.1. (Supports).

## DESIGN VERSIONS

Sliding surfaces (KP):

S – steel

T – PTFE plate with a diameter  $Dt = B - 5$  mm (see 2.10.)

## 31-4

Short, low double-pipe-shoe guide. The height H cannot be changed.

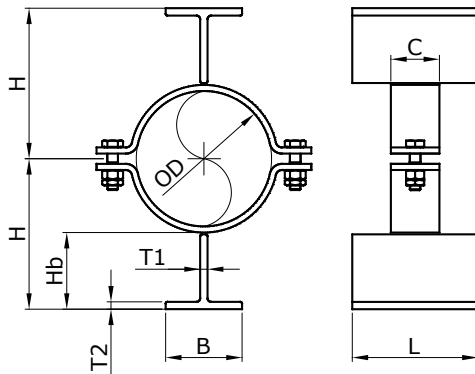

### DESIGNATION

#### 31-4 MS-DNK-H-KP

Example of designation: 31-42-100-70

DNK – pipe outer diameter code

H – required foot height

MS – material group code

KP – sliding surface code

### ASSEMBLY

The clamp bolts are to be hand-tightened until the clamp is in full contact with the pipe and then the bolts are to be tightened by further 180° using a wrench.

### DIMENSIONS AND PARAMETERS

OD	DNK	H	B	L	C	Hb	T1	T2	Fp	m
mm	mm	mm	mm	mm	mm	mm	mm	mm	kN	kg
21,3	015	56	40	100	30	40	5	5	1,0	0,85
26,9	020	59	40	100	30	40	5	5	1,1	0,87
31,8	025	71	50	100	30	50	6	6	1,1	1,18
33,7	025	72	50	100	30	50	6	6	1,0	1,19
38	038	74	50	100	30	50	6	6	0,9	1,20
42,4	032	77	50	100	30	50	6	6	0,9	1,22
48,3	040	80	50	100	30	50	6	6	1,0	1,24
57	057	95	60	120	40	60	7	7	1,8	2,2
60,3	050	97	60	120	40	60	7	7	1,8	2,2
73	073	103	60	120	40	60	7	7	1,8	2,3
76,1	065	105	60	120	40	60	7	7	1,8	2,3
88,9	080	131	80	120	40	80	9	9	1,8	3,4
108	108	142	80	150	50	80	9	9	2,5	4,6
114,3	100	146	80	150	50	80	9	9	2,5	4,7
127	127	172	100	150	50	100	11	11	2,4	6,5
133	133	175	100	150	50	100	11	11	2,4	6,5
139,7	125	178	100	150	50	100	11	11	2,4	6,6
141,3	141	179	100	150	50	100	11	11	2,4	6,6
159	159	188	100	150	50	100	11	11	2,3	6,8
168,3	150	193	100	150	50	100	11	11	2,3	6,9

### MATERIAL GROUPS

MS No.	1	4	7
Tmax (°C)	350	400	350
Material	S235JR	1.4301	S235J2

### DESIGN VERSIONS

Sliding surfaces (KP):

S – steel

T – PTFE plate with a diameter Dt = B - 5 mm (see 2.10).

### PERMISSIBLE LOADS

The load-bearing capacity at higher temperatures and for different materials shall satisfy the following equation:  $F_{pt,M}^G = k_{t,M} \times F_p$  where the correction factor is specified according to table 1.1. (Supports).

## 32-3

Double-pipe-shoe guide with standard or optional height. The height of the guide pipe shoe can be specified in the interval  $0.5 \times H$  to  $1 \times H$ . Also available in long version.

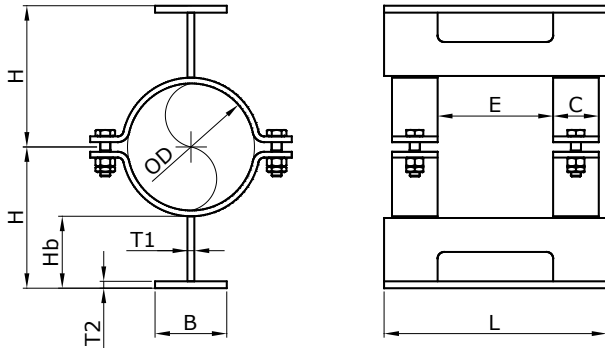

## DESIGNATION

## 32-3(L) MS-DNK-H-KP

Example of designation: 32-3L2-108-280-T

DNK – pipe outer diameter code

H – required foot height

MS – material group code

KP – sliding surface code

L – long version, the character is not normally specified

## ASSEMBLY

The clamp bolts are to be hand-tightened until the clamp is in full contact with the pipe and then the bolts are to be tightened by further  $180^\circ$  using a wrench.

## DIMENSIONS AND PARAMETERS

OD	DNK	H	B	L	Hb	E	C	T1	T2	Fp	m
mm	mm	mm	mm	mm	mm	mm	mm	mm	mm	kN	kg
21,3	015	100	40	150	83	80	30	6	6	2,5	2,2
26,9	020	100	40	100	80	80	30	6	6	2,5	2,2
31,8	025	100	40	100	78	80	30	6	6	2,6	2,3
33,7	025	100	40	100	77	80	30	6	6	2,6	2,3
38	038	120	40	100	95	80	30	6	6	2,2	2,5
42,4	032	120	40	100	92	80	30	6	6	2,2	2,5
48,3	040	120	40	100	89	80	30	6	6	2,3	2,5
57	057	155	50	150	119	110	40	8	8	4,2	5,6
60,3	050	155	50	150	117	110	40	8	8	4,2	5,6
73	073	165	50	150	121	110	40	8	8	4,1	5,8
76,1	065	165	50	150	119	110	40	8	8	4,1	5,8
88,9	080	170	50	150	118	110	40	8	8	4,2	5,9
108	108	200	60	200	137	140	50	10	10	5,7	10,5
114,3	100	200	60	200	133	140	50	10	10	5,7	10,5
127	127	220	80	200	147	140	50	10	10	5,5	12,1
133	133	220	80	200	144	140	50	10	10	5,5	12,1
139,7	125	220	80	200	141	140	50	10	10	5,5	12,1
141,3	141	220	80	200	140	140	50	10	10	5,5	12,1
159	159	240	80	200	151	140	50	10	10	5,3	12,9
168,3	150	240	80	200	146	140	50	10	10	5,3	12,9

## MATERIAL GROUPS

MS No.	1	2	3	4	5	6	7
Tmax (°C)	350	500	580	400	500	620	350
Material	S235JR	16Mo3	10CrMo910	1.4301	1.4571	1.4948	P275NH

## DESIGN VERSIONS

Sliding surfaces (KP):

S – steel

T – PTFE plate with a diameter  $D_t = B - 5$  mm (see 2.10.)

## PERMISSIBLE LOADS

The load-bearing capacity at higher temperatures and for different materials shall satisfy the following equation:  $F_{pt,M}^G = k_{t,M} \times F_{pr}$  where the correction factor is specified according to table 1.1. (Supports).

## 32-4

Low double-pipe-shoe guide. The height H cannot be changed.

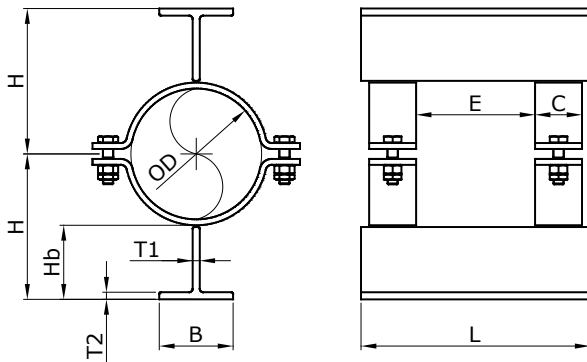

### DESIGNATION

#### 32-4(L) MS-DNK-H-KP

Example of designation: 32-44-125-178

DNK – pipe outer diameter code

H – foot height

MS – material group code

KP – sliding surface code

L – long version, the character is not normally specified

### ASSEMBLY

The clamp bolts are to be hand-tightened until the clamp is in full contact with the pipe and then the bolts are to be tightened by further 180° using a wrench.

### DIMENSIONS AND PARAMETERS

OD	DNK	H	B	L	Hb	E	C	T1	T2	Fp	m
mm	mm	mm	mm	mm	mm	mm	mm	mm	mm	kN	kg
21,3	015	56	40	150	83	80	30	6	6	4,0	1,39
26,9	020	59	40	150	80	80	30	6	6	3,8	1,44
31,8	025	71	50	150	78	80	30	6	6	3,7	1,92
33,7	025	72	50	150	77	80	30	6	6	3,7	1,93
38	038	74	50	150	95	80	30	6	6	3,7	1,96
42,4	032	77	50	150	92	80	30	6	6	3,7	2,0
48,3	040	80	50	150	89	80	30	6	6	3,7	2,0
57	057	95	60	200	119	110	40	8	8	6,5	3,8
60,3	050	97	60	200	117	110	40	8	8	6,5	3,9
73	073	103	60	200	121	110	40	8	8	6,5	4,0
76,1	065	105	60	200	119	110	40	8	8	6,5	4,0
88,9	080	131	80	200	118	110	40	8	8	6,3	6,0
108	108	142	80	250	137	140	50	10	10	7,9	8,2
114,3	100	146	80	250	133	140	50	10	10	7,9	8,3
127	127	172	100	250	147	140	50	10	10	7,8	11,3
133	133	175	100	250	144	140	50	10	10	7,8	11,4
139,7	125	178	100	250	141	140	50	10	10	7,8	11,6
141,3	141	179	100	250	140	140	50	10	10	7,8	11,6
159	159	188	100	250	151	140	50	10	10	7,8	12,0
168,3	150	193	100	250	146	140	50	10	10	7,8	12,1

### MATERIAL GROUPS

MS No.	1	4	7
Tmax (°C)	350	400	350
Material	S235JR	1.4301	S235J2

### DESIGN VERSIONS

Sliding surfaces (KP):

S – steel

T – PTFE plate with a diameter Dt = B - 5 mm (see 2.10.)

### PERMISSIBLE LOADS

The load-bearing capacity at higher temperatures and for different materials shall satisfy the following equation:  $F_{pt,M}^G = k_{t,M} \times F_p$ , where the correction factor is specified according to table 1.1. (Supports).

### 33-2

Triple-pipe-shoe guide with standard or optional height. The height of the guide pipe-shoe can be specified in the interval  $0.5 \times H$  to  $1 \times H$ . Also available in long version.

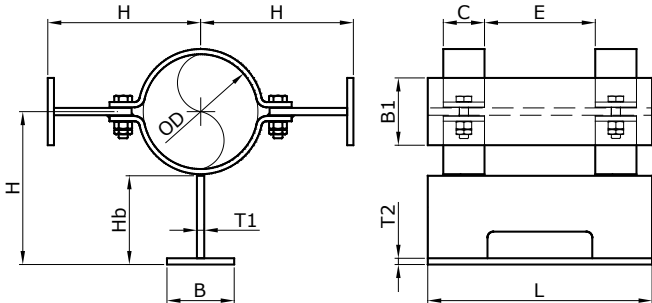

#### DESIGNATION

##### 32-2(L) MS-DNK-H-KP

Example of designation: 33-24-125-178

DNK – pipe outer diameter code

H – required foot height

MS – material group code

KP – sliding surface code

L – long version, the character is not normally specified

#### ASSEMBLY

The clamp bolts are to be hand-tightened until the clamp is in full contact with the pipe and then the bolts are to be tightened by further 180° using a wrench.

#### DIMENSIONS AND PARAMETERS

OD	DNK	H	B	B1	L	Hb	E	C	T1	T2	Fp	m
mm	mm	mm	mm	mm	mm	mm	mm	mm	mm	mm	kN	kg
21,3	015	100	40	30	150	83	80	30	6	6	2,5	3,1
26,9	020	100	40	30	100	80	80	30	6	6	2,5	3,1
31,8	025	100	40	30	100	78	80	30	6	6	2,6	3,1
33,7	025	100	40	30	100	77	80	30	6	6	2,6	3,1
38	038	120	40	30	100	95	80	30	6	6	2,2	3,5
42,4	032	120	40	30	100	92	80	30	6	6	2,2	3,5
48,3	040	120	40	30	100	89	80	30	6	6	2,3	3,4
57	057	155	50	40	150	119	110	40	8	8	4,2	7,7
60,3	050	155	50	40	150	117	110	40	8	8	4,2	7,7
73	073	165	50	40	150	121	110	40	8	8	4,1	8,0
76,1	065	165	50	40	150	119	110	40	8	8	4,1	7,9
88,9	080	170	50	40	150	118	110	40	8	8	4,2	8,0
108	108	200	60	40	200	137	140	50	10	10	5,7	14,4
114,3	100	200	60	40	200	133	140	50	10	10	5,7	14,3
127	127	220	80	50	200	147	140	50	10	10	5,5	16,5
133	133	220	80	50	200	144	140	50	10	10	5,5	16,5
139,7	125	220	80	50	200	141	140	50	10	10	5,5	16,4
141,3	141	220	80	50	200	140	140	50	10	10	5,5	16,4
159	159	240	80	50	200	151	140	50	10	10	5,3	17,4
168,3	150	240	80	50	200	146	140	50	10	10	5,3	17,3

#### MATERIAL GROUPS

MS No.	1	2	3	4	5	6	7
Tmax (°C)	350	500	580	400	500	620	350
Material	S235JR	16Mo3	10CrMo910	1.4301	1.4571	1.4948	P275NH

#### DESIGN VERSIONS

Sliding surfaces (KP):

S – steel

T – PTFE plate with a diameter  $D_t = B - 5$  mm (see 2.10)

#### PERMISSIBLE LOADS

The load-bearing capacity at higher temperatures and for different materials shall satisfy the following equation:  $F_{pL,M}^G = k_{L,M} \times F_{p'}^G$ , where the correction factor is specified according to table 1.1. (Supports).

## 34-2

Quadruple-pipe-shoe guide with standard or optional height. The height of the guide pipe shoe can be specified in the interval 0.5xH to 1xH. Also available in long version.

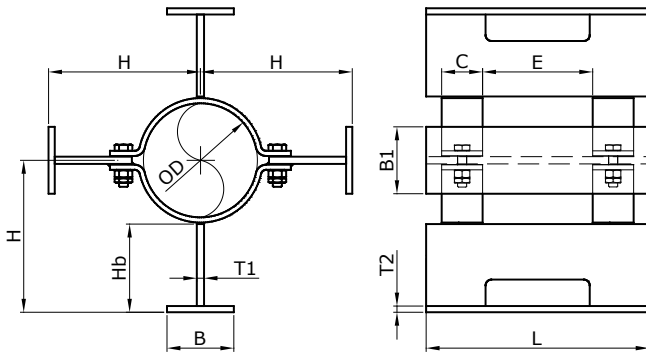

### DESIGNATION

#### 32-2(L) MS-DNK-H-KP

Example of designation: 34-2L7-141-170-T

DNK – pipe outer diameter code

H – required foot height

MS – material group code

KP – sliding surface code

L – long version, the character is not normally specified

### ASSEMBLY

The clamp bolts are to be hand-tightened until the clamp is in full contact with the pipe and then the bolts are to be tightened by further 180° using a wrench.

### DIMENSIONS AND PARAMETERS

OD	DNK	H	B	B1	L	Hb	E	C	T1	T2	Fp	m
mm	mm	mm	mm	mm	mm	mm	mm	mm	mm	mm	kN	kg
21,3	015	100	40	30	150	83	80	30	6	6	2,5	4,0
26,9	020	100	40	30	100	80	80	30	6	6	2,5	3,9
31,8	025	100	40	30	100	78	80	30	6	6	2,6	3,9
33,7	025	100	40	30	100	77	80	30	6	6	2,6	3,9
38	038	120	40	30	100	95	80	30	6	6	2,2	4,4
42,4	032	120	40	30	100	92	80	30	6	6	2,2	4,4
48,3	040	120	40	30	100	89	80	30	6	6	2,3	4,4
57	057	155	50	40	150	119	110	40	8	8	4,2	9,8
60,3	050	155	50	40	150	117	110	40	8	8	4,2	9,8
73	073	165	50	40	150	121	110	40	8	8	4,1	10,1
76,1	065	165	50	40	150	119	110	40	8	8	4,1	10,0
88,9	080	170	50	40	150	118	110	40	8	8	4,2	10,1
108	108	200	60	40	200	137	140	50	10	10	5,7	18,3
114,3	100	200	60	40	200	133	140	50	10	10	5,7	18,1
127	127	220	80	50	200	147	140	50	10	10	5,5	21,0
133	133	220	80	50	200	144	140	50	10	10	5,5	20,9
139,7	125	220	80	50	200	141	140	50	10	10	5,5	20,7
141,3	141	220	80	50	200	140	140	50	10	10	5,5	20,7
159	159	240	80	50	200	151	140	50	10	10	5,3	21,9
168,3	150	240	80	50	200	146	140	50	10	10	5,3	21,7

### MATERIAL GROUPS

MS No.	1	2	4	5	7
Tmax (°C)	350	500	400	500	350
Material	S235JR	16Mo3	1.4301	1.4571	P275NH

### DESIGN VERSIONS

Sliding surfaces (KP):

S – steel

T – PTFE plate with a diameter Dt = B - 5 mm (see 2.10.)

### PERMISSIBLE LOADS

The load-bearing capacity at higher temperatures and for different materials shall satisfy the following equation:  $F_{pt,M}^G = k_{t,M} \times F_{p'}^G$ , where the correction factor is specified according to table 1.1. (Supports).

## 35-1

Low guide for uninsulated piping. The height H cannot be changed.

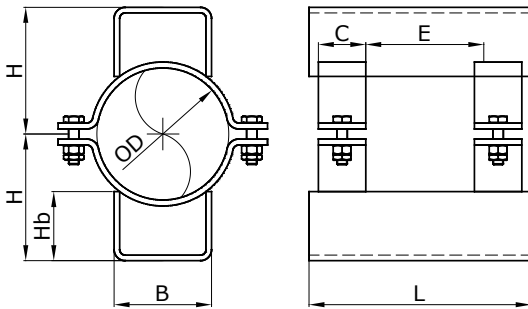

## DESIGNATION

## 35-1 MS-DNK-H-KP

Example of designation: 35-11-080-94

DNK – pipe outer diameter code

MS – material group code

KP – sliding surface code

## ASSEMBLY

The clamp bolts are to be hand-tightened until the clamp is in full contact with the pipe and then the bolts are to be tightened by further 180° using a wrench.

## DIMENSIONS AND PARAMETERS

OD	DNK	H	B	L	Hb	C	E	F <sub>py</sub>	F <sub>pz</sub>	m
mm	mm	mm	mm	mm	mm	mm	mm	kN	kN	kg
57	057	74	60	180	50	40	80	1,4	6,4	3,1
60,3	050	76	60	180	50	40	80	1,4	6,4	3,1
73	073	85	60	180	50	40	80	1,4	6,4	3,3
76,1	065	87	60	180	50	40	80	1,4	6,4	3,3
88,9	080	94	60	180	50	40	80	1,4	6,4	3,5
108	108	111	80	220	60	50	100	2,0	11,4	5,5
114,3	100	115	80	220	60	50	100	2,0	11,4	5,6
127	127	123	80	220	60	50	100	1,9	11,4	5,9
133	133	126	80	220	60	50	100	1,9	11,4	6,0
139,7	125	130	80	220	60	50	100	1,9	11,4	6,1
141,3	141	131	80	220	60	50	100	1,9	11,4	6,2
159	159	129	120	220	60	50	100	2,2	11,4	7,9
168,3	150	135	120	220	60	50	100	2,2	11,4	8,0
193,7	175	150	120	220	60	50	100	2,2	11,4	8,5
219,1	200	165	120	220	60	50	100	2,2	13,8	9,0
244,5	225	179	120	260	60	60	120	2,6	13,8	12,8
273	250	205	160	260	80	60	120	2,6	13,8	16,3
323,9	300	234	160	260	80	60	120	3,3	13,8	17,5
355,6	350	251	160	260	80	60	120	2,9	16,2	18,3
377	377	263	160	260	80	60	120	2,9	16,2	18,8
406,4	400	290	210	300	100	70	140	3,3	16,1	29,3
426	426	301	210	300	100	70	140	3,3	16,1	30,0
457	450	318	210	300	100	70	140	3,3	16,1	31,1
508	500	324	300	300	100	70	140	3,3	22,4	40,0
530	530	337	300	300	100	70	140	3,3	22,4	40,7
559	550	359	300	380	100	90	180	4,3	29,2	69,5
609,6	600	394	350	380	120	90	180	5,7	38,2	77,1
630	630	406	350	380	120	90	180	5,7	38,2	78,5
664	650	423	350	380	120	90	180	5,6	33,3	80,8
711,2	700	428	430	380	120	90	180	5,6	33,3	87,6
720	720	434	430	380	120	90	180	5,6	33,3	88,3
762	750	459	430	380	120	90	180	5,6	33,3	91,2
812,8	800	488	430	380	120	90	180	5,6	33,3	94,5
820	820	492	430	380	120	90	180	5,6	33,3	95,1

## MATERIAL GROUPS

MS No.	1	4
Tmax (°C)	350	400
Material	S235JR	1.4301

## DESIGN VERSIONS

Sliding surfaces (KP):

S – steel

M – stainless steel mirror

T – PTFE plate with a diameter Dt = B - 5 mm (see 2.10.)

## PERMISSIBLE LOADS

F<sub>py</sub> – load perpendicular to the pipe-shoe axis (shown horizontally perpendicular to pipe axis), F<sub>pz</sub> – load in the direction of pipe-shoe axis (shown vertically in the picture).

Resultant external force must satisfy the following equation for total load:  $F_y/F_p + F_z/F_p \leq 1$ .

The load-bearing capacity at higher temperatures and for different materials shall satisfy the following equation:  $F_{pt,M}^G = k_{t,M} \times F_{pr}$  where the correction factor is specified according to table 1.1. (Supports).



## 36-3

Double-pipe-shoe guide with standard or optional height. The pipe-shoe height can be specified in the interval  $0.5 \times H$  to  $1.2 \times H$ . Also available in long version. The guide can also be loaded by a force perpendicular to the axis of the pipe shoes (See picture in chapter 2.1).

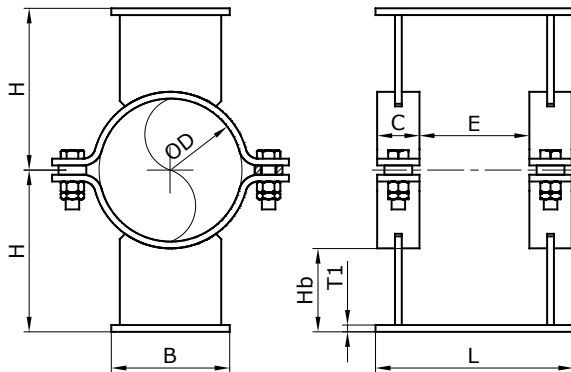

## DIMENSIONS AND PARAMETERS

OD	DNK	H	B	L	Hb	C	E	T1	Fpy	Fpz	m
mm	mm	mm	mm	mm	mm	mm	mm	mm	kN	kN	kg
57	057	155	80	200	120,5	40	100	8	1,8	4,4	4,5
60,3	050	155	80	200	118,85	40	100	8	1,8	4,4	4,5
73	073	165	85	200	122,5	40	100	8	2,3	5,3	5,0
76,1	065	165	85	200	120,95	40	100	8	2,3	5,3	5,1
88,9	080	170	85	200	119,55	40	100	8	2,3	5,4	5,2
108	108	200	100	240	138	50	120	10	4,7	7,9	9,3
114,3	100	200	100	240	134,85	50	120	10	4,7	7,9	9,4
127	127	220	120	240	148,5	50	120	10	5,9	9,5	11,4
133	133	220	120	240	145,5	50	120	10	5,9	9,5	11,5
139,7	125	220	120	240	142,15	50	120	10	5,9	9,5	11,5
141,3	141	220	120	240	141,35	50	120	10	5,9	9,5	11,5
159	159	240	120	240	152,5	50	120	10	5,7	9,5	12,1
168,3	150	240	120	240	147,85	50	120	10	5,7	9,5	12,2
193,7	175	270	140	240	165,15	50	120	10	6,7	11,1	14,7
219,1	200	290	150	240	172,45	50	120	10	7,2	11,9	16,3
244,5	225	300	150	240	169,75	60	100	12	10,5	17,1	22
273	250	330	165	300	185,5	60	160	12	11,1	15,7	26
323,9	300	380	190	300	210,05	60	160	12	12,1	18,0	32
355,6	350	400	200	300	214,2	60	160	12	12,8	19,0	34
377	377	400	200	300	203,5	60	160	12	12,8	19,0	34
406,4	400	430	205	350	216,8	70	190	15	17,7	26,1	50
426	426	430	205	350	207	70	190	15	17,7	26,1	50
457	450	470	225	350	231,5	70	190	15	18,4	28,6	56
508	500	500	230	350	236	70	190	15	19,2	29,2	59
530	530	500	230	350	225	70	190	15	19,2	29,2	59
559	550	530	240	350	235,5	90	150	15	20,4	30,5	85
609,6	600	560	255	450	240,2	90	250	15	20,6	25,2	97
630	630	560	255	450	230	90	250	15	20,6	25,2	97
664	650	590	270	450	243	90	250	20	25,4	38,8	119
711,2	700	630	290	450	259,4	90	250	20	30,5	46,7	129
720	720	630	320	450	255	90	250	20	30,5	46,7	137
762	750	670	340	450	274	90	250	20	31,5	49,2	148
812,8	800	700	340	450	278,6	90	250	20	31,0	48,9	152
820	820	700	340	450	275	90	250	20	31,0	48,9	152

## MATERIAL GROUPS

MS No.	1	2	3	4	5	6	7
Tmax (°C)	350	500	580	400	500	620	350
Material	S235JR	16Mo3	10CrMo910	1.4301	1.4571	1.4948	P275NH

## DESIGN VERSIONS

Sliding surfaces (KP): S – steel, M – stainless steel mirror, T – PTFE plate with a diameter of  $D_t = B - 5$  mm (see 2.10.), B – bronze-graphite plate  
 Long version – the support length is 1.5 times longer than the standard length L. Other dimensions remain unchanged; the weight is 1.5 times the tabular value of m.

## DESIGNATION

## 36-3(L) MS-DNK-H-KP

Example of designation: 36-34-150-220-T

DNK – pipe outer diameter code, H – required foot height, MS – material group code, KP – sliding surface code, L – long design, no character is normally specified.

## ASSEMBLY

The clamp bolts are to be hand-tightened until the clamp is in full contact with the pipe and then the bolts are to be tightened by further  $180^\circ$  using a wrench.

## PERMISSIBLE LOADS

$F_{py}$  – load perpendicular to the pipe-shoe axis (shown horizontally perpendicular to pipe axis),  $F_{pz}$  – load in the direction of pipe-shoe axis (shown vertically in the picture).

Resultant external force must satisfy the following equation for total load:  $F_y/F_p + F_z/F_p \leq 1$ .

The load-bearing capacity at higher temperatures and for different materials shall satisfy the following equation:  $F_{pt,M}^G = k_{t,M} \times F_{pt}$  where the correction factor is specified according to table 1.1. (Supports).

### 36-4

Double-pipe-shoe guide with standard or optional height. The pipe-shoe height can be specified in the interval  $0.5 \times H$  to  $1.2 \times H$ . Also available in long version.

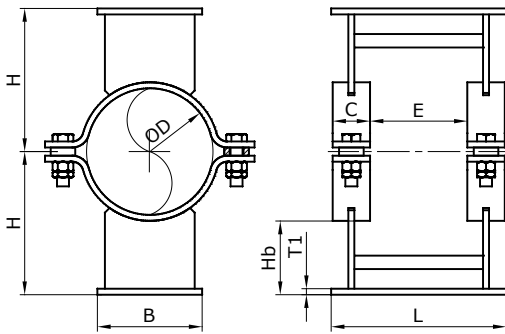

#### DIMENSIONS AND PARAMETERS

OD	DNK	H	B	L	Hb	C	E	T1	Fpy	Fpz	m
mm	mm	mm	mm	mm	mm	mm	mm	mm	kN	kN	kg
57	057	155	80	200	120,5	40	100	8	1,8	7,5	5,2
60,3	050	155	80	200	118,85	40	100	8	1,8	7,5	5,3
73	073	165	85	200	122,5	40	100	8	2,3	9,4	5,8
76,1	065	165	85	200	120,95	40	100	8	2,3	9,4	5,8
88,9	080	170	85	200	119,55	40	100	8	2,3	9,5	6,0
108	108	200	100	240	138	50	120	10	4,7	12,9	11,0
114,3	100	200	100	240	134,85	50	120	10	4,7	12,9	11,0
127	127	220	120	240	148,5	50	120	10	5,9	15,4	13,0
133	133	220	120	240	145,5	50	120	10	5,9	15,4	13,1
139,7	125	220	120	240	142,15	50	120	10	5,9	15,4	13,1
141,3	141	220	120	240	141,35	50	120	10	5,9	15,4	13,2
159	159	240	120	240	152,5	50	120	10	5,7	15,4	13,8
168,3	150	240	120	240	147,85	50	120	10	5,7	15,4	13,8
193,7	175	270	140	240	165,15	50	120	10	6,7	18,0	16,4
219,1	200	290	150	240	172,45	50	120	10	7,2	19,3	17,9
244,5	225	300	150	240	169,75	60	100	12	10,5	27,8	23,6
273	250	330	165	300	185,5	60	160	12	11,1	21,5	29,7
323,9	300	380	190	300	210,05	60	160	12	12,1	24,8	35
355,6	350	400	200	300	214,2	60	160	12	12,8	26,1	37
377	377	400	200	300	203,5	60	160	12	12,8	26,1	37
406,4	400	430	205	350	216,8	70	190	15	17,7	32,1	55
426	426	430	205	350	207	70	190	15	17,7	32,1	55
457	450	470	225	350	231,5	70	190	15	18,4	35,2	60
508	500	500	230	350	236	70	190	15	19,2	36,0	64
530	530	500	230	350	225	70	190	15	19,2	36,0	64
559	550	530	240	350	235,5	90	150	15	20,4	37,5	90
609,6	600	560	255	450	240,2	90	250	15	20,6	27,0	103
630	630	560	255	450	230	90	250	15	20,6	27,0	106
664	650	590	270	450	243	90	250	20	25,4	50,8	130
711,2	700	630	290	450	259,4	90	250	20	30,5	60,2	140
720	720	630	320	450	255	90	250	20	30,5	60,2	148
762	750	670	340	450	274	90	250	20	31,5	64,0	159
812,8	800	700	340	450	278,6	90	250	20	31,0	64,0	163
820	820	700	340	450	275	90	250	20	31,0	64,0	163

#### MATERIAL GROUPS

MS No.	1	2	3	4	5	6	7
Tmax (°C)	350	500	580	400	500	620	350
Material	S235JR	16Mo3	10CrMo910	1.4301	1.4571	1.4948	P275NH

#### DESIGN VERSIONS

Sliding surfaces (KP): S – steel, M – stainless steel mirror, T – PTFE plate with a diameter of  $Dt = B - 5 \text{ mm}$  (see 2.10.), B – bronze-graphite plate.  
 Long version – the support length is 1.5 times longer than the standard length L. Other dimensions remain unchanged; the weight is 1.5 times the tabular value of m.

#### DESIGNATION

##### 36-4(L) MS-DNK-H-KP

Example of designation: 36-4L3-530-510

DNK – pipe outer diameter code, H – required foot height, MS – material group code, KP – sliding surface code, L – long design, no character is normally specified.

#### ASSEMBLY

The clamp bolts are to be hand-tightened until the clamp is in full contact with the pipe and then the bolts are to be tightened by further 180° using a wrench.

#### PERMISSIBLE LOADS

$F_{py}$  – load perpendicular to the pipe-shoe axis (shown horizontally perpendicularly to pipe axis),  $F_{pz}$  – load in the direction of pipe-shoe axis (shown vertically in the picture). Resultant external force must satisfy the following equation for total load:  $F_y/F_p + F_z/F_p \leq 1$ .

The load-bearing capacity at higher temperatures and for different materials shall satisfy the following equation:  $F_{pt,M}^G = k_{t,M} \times F_{pr}$ , where the correction factor is specified according to table 1.1. (Supports).

## 37-3

Triple-pipe-shoe guide with standard or optional height. The pipe-shoe height can be specified in the interval  $0.5 \times H$  to  $1.2 \times H$ . Also available in long version.

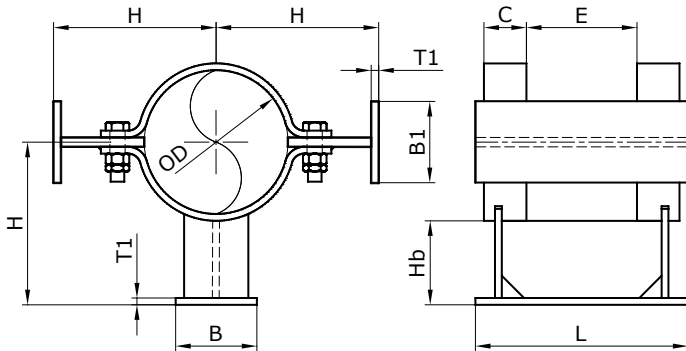

## DESIGNATION

## 37-3(L) MS-DNK-H-KP

Example of designation: 37-32-141-220

DNK – pipe outer diameter code, H – required foot height, MS – material group code, KP – sliding surface code, L – long design, no character is normally specified.

## ASSEMBLY

The clamp bolts are to be hand-tightened until the clamp is in full contact with the pipe and then the bolts are to be tightened by further 180° using a wrench.

## DIMENSIONS AND PARAMETERS

OD	DNK	H	B	B1	L	Hb	C	E	T1	Fpy	Fpz	m
mm	mm	mm	mm	mm	mm	mm	mm	mm	mm	kN	kN	kg
57	057	155	80	50	200	121	40	100	6	4,3	4,3	7,5
60,3	050	155	80	50	200	119	40	100	6	4,3	4,3	7,4
73	073	165	85	50	200	123	40	100	6	5,2	5,2	7,9
76,1	065	165	85	50	200	121	40	100	6	5,2	5,2	7,9
88,9	080	170	85	50	200	120	40	100	6	5,4	5,4	8,0
108	108	200	100	60	240	138	50	120	8	10,0	12,1	15,2
114,3	100	200	100	60	240	135	50	120	8	10,0	12,1	15,1
127	127	220	120	80	240	149	50	120	8	9,3	14,0	17,6
133	133	220	120	80	240	146	50	120	8	9,3	14,0	17,5
139,7	125	220	120	80	240	142	50	120	8	9,3	14,0	17,4
141,3	141	220	120	80	240	141	50	120	8	9,3	14,0	17,4
159	159	240	120	80	240	153	50	120	8	8,7	13,5	18,5
168,3	150	240	120	80	240	148	50	120	8	8,7	13,5	18,4
193,7	175	270	140	80	240	165	50	120	8	8,1	14,7	20,8
219,1	200	290	150	80	240	172	50	120	8	7,6	15,2	22,2
244,5	225	300	150	80	240	170	60	100	10	9,1	22,8	29,0
273	250	330	165	100	300	186	60	160	10	10,1	26,2	37,7
323,9	300	380	190	100	300	210	60	160	10	9,0	26,0	43,2
355,6	350	400	200	100	300	214	60	160	10	8,4	26,9	44,9
377	377	400	200	100	300	204	60	160	10	8,4	26,9	44,2
406,4	400	430	205	120	350	217	70	190	12	10,8	37,5	69,1
426	426	430	205	120	350	207	70	190	12	10,8	37,5	68,1
457	450	470	225	120	350	232	70	190	12	10,2	37,3	74,8
508	500	500	230	120	350	236	70	190	12	9,4	38,4	77,9
530	530	500	230	120	350	225	70	190	12	9,4	38,4	76,7
559	550	530	240	120	350	236	90	150	12	10,9	40,6	110
609,6	600	560	255	150	450	240	90	250	12	13,1	40,5	134
630	630	560	255	150	450	230	90	250	12	13,1	40,5	132
664	650	590	270	150	450	243	90	250	15	12,2	65,3	150
711,2	700	630	290	160	450	259	90	250	15	11,9	73,8	160
720	720	630	320	160	450	255	90	250	15	11,9	73,8	163
762	750	670	340	170	450	274	90	250	15	11,3	72,8	175
812,8	800	700	340	170	450	279	90	250	15	10,8	70,9	180
820	820	700	340	170	450	275	90	250	15	10,8	70,9	179

## MATERIAL GROUPS

MS No.	1	2	3	4	5	6	7
Tmax (°C)	350	500	580	400	500	620	350
Material	S235JR	16Mo3	10CrMo910	1.4301	1.4571	1.4948	P275NH

## DESIGN VERSIONS

Sliding surfaces (KP): S – steel

T – PTFE plate with a diameter  $D_t = B - 5$  mm (see 2.10.)

## PERMISSIBLE LOADS

The load-bearing capacity at higher temperatures and for different materials shall satisfy the following equation:  $F_{pt,M}^G = k_{t,M} \times F_p$ , where the correction factor is specified according to table 1.1. (Supports).

## 31-1

Short double-pipe-shoe guide with standard or optional heights. The pipe-shoe height can be specified in the interval  $0.5 \times H$  to  $1 \times H$ .

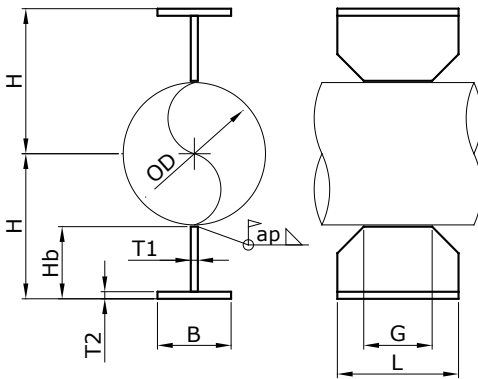

## DESIGNATION

## 31-1 MS-DNK-H-KP

Example of designation: 31-11-065-165

DNK – pipe outer diameter code

H – required foot height

MS – material group code

KP – sliding surface code

## ASSEMBLY

The pipe shoes are welded to the pipe with a continuous fillet weld (weld size ap).

## DIMENSIONS AND PARAMETERS

OD	DNK	H	B	L	Hb	ap	T1	T2	G	Fp	m
mm	mm	mm	mm	mm	mm	mm	mm	mm	mm	kN	kg
21,3	015	100	40	100	82	3	6	6	80	2,6	1,21
26,9	020	100	40	100	79	3	6	6	80	2,7	1,18
31,8	025	100	40	100	77	3	6	6	80	2,8	1,16
33,7	025	100	40	100	76	3	6	6	80	2,8	1,15
38	038	120	40	100	94	3	6	6	80	2,4	1,32
42,4	032	120	40	100	91	3	6	6	80	2,4	1,29
48,3	040	120	40	100	88	3	6	6	80	2,5	1,26
57	057	155	50	150	117	4	8	8	100	4,9	3,3
60,3	050	155	50	150	115	4	8	8	100	4,9	3,3
73	073	165	50	150	119	4	8	8	100	4,8	3,3
76,1	065	165	50	150	117	4	8	8	100	4,8	3,3
88,9	080	170	50	150	116	4	8	8	100	4,9	3,3
108	108	200	60	200	135	4	10	10	130	6,9	6,4
114,3	100	200	60	200	131	4	10	10	130	6,9	6,3
127	127	220	80	200	145	4	10	10	130	6,6	7,4
133	133	220	80	200	142	4	10	10	130	6,6	7,3
139,7	125	220	80	200	139	4	10	10	130	6,6	7,2
141,3	141	220	80	200	138	4	10	10	130	6,6	7,2
159	159	240	80	200	149	4	10	10	130	6,4	7,5
168,3	150	240	80	200	144	4	10	10	130	6,4	7,3

## MATERIAL GROUPS

MS No.	1	2	4	5	7
Tmax (°C)	350	500	400	500	350
Material	S235JR	16Mo3	1.4301	1.4571	P275NH

## DESIGN VERSIONS

Sliding surfaces (KP):

S – steel

T – PTFE plate with a diameter  $D_t = B - 5 \text{ mm}$  (see 2.10.)

## PERMISSIBLE LOADS

The load-bearing capacity at higher temperatures and for different materials shall satisfy the following equation:  $F_{pt,M}^G = k_{t,M} \times F_p$ , where the correction factor is specified according to table 1.1. (Supports).

## 31-2

Short, low double-pipe-shoe guide. The height H cannot be changed.

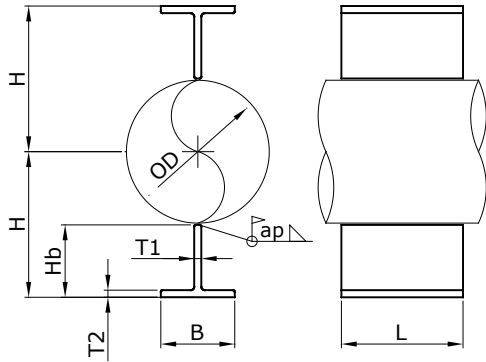

### DESIGNATION

#### 31-2 MS-DNK-H-KP

Example of designation: 31-21-100-138

DNK – pipe outer diameter code

H – required foot height

MS – material group code

KP – sliding surface code

### ASSEMBLY

The pipe shoes are welded to the pipe with a continuous fillet weld (weld size ap).

### DIMENSIONS AND PARAMETERS

OD	DNK	H	B	L	Hb	ap	T1	T2	Fp	m	m
mm	mm	mm	mm	mm	mm	mm	mm	mm	kN	kg	kg
21,3	015	51	40	100	40	3	5	5	5,4	0,59	1,45
26,9	020	54	40	100	40	3	5	5	5,4	0,59	1,47
31,8	025	66	50	100	50	3	6	6	5,1	0,89	1,50
33,7	025	67	50	100	50	3	6	6	5,1	0,89	1,50
38	038	69	50	100	50	3	6	6	5,1	0,89	1,73
42,4	032	72	50	100	50	3	6	6	5,1	0,89	1,74
48,3	040	75	50	100	50	3	6	6	5,1	0,89	1,76
57	057	89	60	120	60	4	7	7	8,4	1,50	3,8
60,3	050	91	60	120	60	4	7	7	8,4	1,50	3,8
73	073	97	60	120	60	4	7	7	8,4	1,50	4,2
76,1	065	99	60	120	60	4	7	7	8,4	1,50	4,2
88,9	080	125	80	120	80	4	9	9	8,0	2,6	4,3
108	108	134	80	150	80	4	9	9	10,6	3,2	7,4
114,3	100	138	80	150	80	4	9	9	10,6	3,2	7,5
127	127	164	100	150	100	4	11	11	10,2	3,3	8,4
133	133	167	100	150	100	4	11	11	10,2	3,4	8,5
139,7	125	170	100	150	100	4	11	11	10,2	3,6	8,5
141,3	141	171	100	150	100	4	11	11	10,2	3,7	8,6
159	159	180	100	150	100	4	11	11	10,2	4,1	9,1
168,3	150	185	100	150	100	4	11	11	10,2	4,4	9,2

### MATERIAL GROUPS

MS No.	1	4	7
Tmax (°C)	350	400	350
Material	S235JR	1.4301	S235J2

### DESIGN VERSIONS

Sliding surfaces (KP):

S – steel

### PERMISSIBLE LOADS

The load-bearing capacity at higher temperatures and for different materials shall satisfy the following equation:  $F_{pt,M}^G = k_{t,M} \times F_p$ , where the correction factor is specified according to table 1.1. (Supports).

## 32-1

Double-pipe-shoe guide with standard or optional height. The pipe-shoe height can be specified in the interval  $0.5 \times H$  to  $1 \times H$ . Also available in long version.

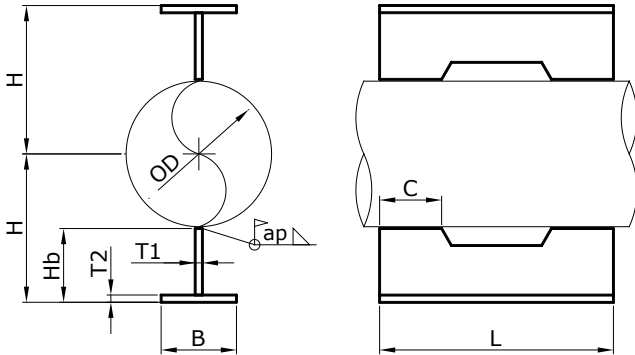

## DESIGNATION

## 32-1(L) MS-DNK-H-KP

Example of designation: 32-1L2-108-185-M

DNK – pipe outer diameter code

H – required foot height

MS – material group code

KP – sliding surface code

L – long version, the character is not normally specified

## ASSEMBLY

The pipe shoes are welded to the pipe with a continuous fillet weld (weld size ap).

## DIMENSIONS AND PARAMETERS

OD	DNK	H	B	L	Hb	ap	T1	T2	C	Fp	m
mm	mm	mm	mm	mm	mm	mm	mm	mm	mm	kN	kg
21,3	015	100	40	150	82	3	6	6	40	4,4	1,81
26,9	020	100	40	150	79	3	6	6	40	4,5	1,77
31,8	025	100	40	150	77	3	6	6	40	4,6	1,74
33,7	025	100	40	150	76	3	6	6	40	4,6	1,72
38	038	120	40	150	94	3	6	6	40	4,0	1,98
42,4	032	120	40	150	91	3	6	6	40	4,0	1,94
48,3	040	120	40	150	88	3	6	6	40	4,1	1,89
57	057	155	50	200	117	4	8	8	50	7,5	4,4
60,3	050	155	50	200	115	4	8	8	50	7,5	4,3
73	073	165	50	200	119	4	8	8	50	7,4	4,4
76,1	065	165	50	200	117	4	8	8	50	7,4	4,4
88,9	080	170	50	200	116	4	8	8	50	7,5	4,4
108	108	200	60	250	135	4	10	10	65	10,0	8,0
114,3	100	200	60	250	131	4	10	10	65	10,0	7,9
127	127	220	80	250	145	4	10	10	65	9,7	9,2
133	133	220	80	250	142	4	10	10	65	9,7	9,1
139,7	125	220	80	250	139	4	10	10	65	9,7	9,0
141,3	141	220	80	250	138	4	10	10	65	9,7	8,9
159	159	240	80	250	149	4	10	10	65	9,4	9,4
168,3	150	240	80	250	144	4	10	10	65	9,4	9,2

Dimension F = 30–50 mm

## MATERIAL GROUPS

MS No.	1	2	4	5	7
Tmax (°C)	350	500	400	500	350
Material	S235JR	16Mo3	1.4301	1.4571	P275NH

## DESIGN VERSIONS

Sliding surfaces (KP):

S – steel

T – PTFE plate with a diameter  $Dt = B - 5$  mm (see 2.10.)

## PERMISSIBLE LOADS

The load-bearing capacity at higher temperatures and for different materials shall satisfy the following equation:  $F_{pt,M}^G = k_{t,M} \times F_{pr}$ , where the correction factor is specified according to table 1.1. (Supports).

## 32-2

Low double-pipe-shoe guide. The height H cannot be changed.

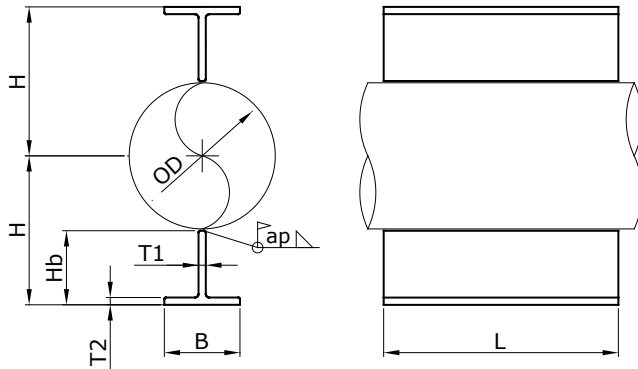

## DESIGNATION

## 32-2 MS-DNK-H-KP

Example of designation: 32-24-80-125

DNK – pipe outer diameter code

H – foot height

MS – material group code

KP – sliding surface code

L – long version, the character is not normally specified

## ASSEMBLY

The pipe shoes are welded to the pipe with a continuous fillet weld (weld size ap).

## DIMENSIONS AND PARAMETERS

OD	DNK	H	B	L	Hb	ap	T1	T2	Fp	m
mm	mm	mm	mm	mm	mm	mm	mm	mm	kN	kg
21,3	015	51	40	150	40	3	5	5	8,6	0,89
26,9	020	54	40	150	40	3	5	5	8,1	0,89
31,8	025	66	50	150	50	3	6	6	8,0	1,33
33,7	025	67	50	150	50	3	6	6	8,0	1,33
38	038	69	50	150	50	3	6	6	8,0	1,33
42,4	032	72	50	150	50	3	6	6	8,0	1,33
48,3	040	75	50	150	50	3	6	6	8,0	1,33
57	057	89	60	200	60	4	7	7	13,2	2,5
60,3	050	91	60	200	60	4	7	7	13,2	2,5
73	073	97	60	200	60	4	7	7	13,2	2,5
76,1	065	99	60	200	60	4	7	7	13,2	2,5
88,9	080	125	80	200	80	4	9	9	12,9	4,3
108	108	134	80	250	80	4	9	9	15,5	5,4
114,3	100	138	80	250	80	4	9	9	15,5	5,4
127	127	164	100	250	100	4	11	11	15,2	8,2
133	133	167	100	250	100	4	11	11	15,2	8,2
139,7	125	170	100	250	100	4	11	11	15,2	8,2
141,3	141	171	100	250	100	4	11	11	15,2	8,2
159	159	180	100	250	100	4	11	11	15,2	8,2
168,3	150	185	100	250	100	4	11	11	15,2	8,2

## MATERIAL GROUPS

MS No.	1	4	7
Tmax (°C)	350	400	350
Material	S235JR	1.4301	S235J2

## DESIGN VERSIONS

Sliding surfaces (KP):

S – steel

T – PTFE plate with a diameter Dt = B - 5 mm (see 2.10.)

## PERMISSIBLE LOADS

The load-bearing capacity at higher temperatures and for different materials shall satisfy the following equation:  $F_{pt,M}^G = k_{L,M} \times F_{pr}^G$ , where the correction factor is specified according to table 1.1. (Supports).

## 33-1

Triple-pipe-shoe guide with standard or optional height. The pipe-shoe height can be specified in the interval  $0.5 \times H$  to  $1 \times H$ . Also available in long version.

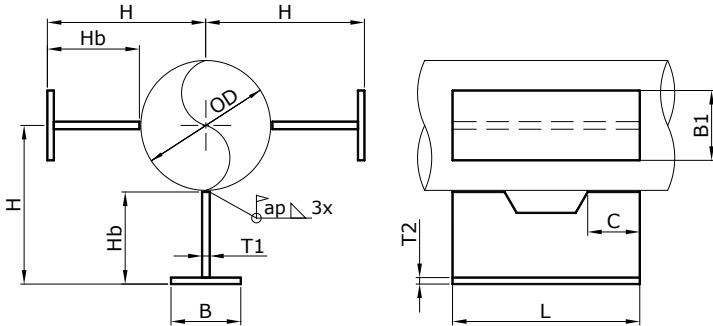

## DESIGNATION

## 33-1(L) MS-DNK-H-KP

Example of designation: 33-17-050-155-T

DNK – pipe outer diameter code

H – required foot height

MS – material group code

KP – sliding surface code

L – long version, the character is not normally specified

## ASSEMBLY

The pipe shoes are welded to the pipe with a continuous fillet weld (weld size ap).

## DIMENSIONS AND PARAMETERS

DNK	OD	B	B1	H	L	Hb	ap	T1	T2	C	F	m
mm	mm	mm	mm	mm	mm	mm	mm	mm	mm	mm	mm	kg
015	21,3	40	30	100	150	88	3	6	6	40	30	2,7
020	26,9	40	30	100	150	85	3	6	6	40	30	2,6
025	31,8	40	30	100	150	83	3	6	6	40	30	2,6
025	33,7	40	30	100	150	82	3	6	6	40	30	2,6
038	38	40	30	120	150	100	3	6	6	40	30	3,0
032	42,4	40	30	120	150	97	3	6	6	40	30	2,9
040	48,3	40	30	120	150	94	3	6	6	40	30	2,8
057	57	50	40	155	200	125	4	8	8	50	40	6,6
050	60,3	50	40	155	200	123	4	8	8	50	40	6,5
073	73	50	40	165	200	127	4	8	8	50	40	6,7
065	76,1	50	40	165	200	125	4	8	8	50	40	6,6
080	88,9	50	40	170	200	124	4	8	8	50	40	6,6
108	108	60	40	200	250	145	4	10	10	65	40	12,1
100	114,3	60	40	200	250	141	4	10	10	65	40	11,8
127	127	80	50	220	250	155	4	10	10	65	40	13,8
133	133	80	50	220	250	152	4	10	10	65	40	13,7
125	139,7	80	50	220	250	149	4	10	10	65	40	13,5
141	141,3	80	50	220	250	148	4	10	10	65	40	13,4
159	159	80	50	240	250	159	4	10	10	65	40	14,1
150	168,3	80	50	240	250	154	4	10	10	65	40	13,8

Dimension F = 30-50 mm

## MATERIAL GROUPS

MS No.	1	2	4	5	7
Tmax (°C)	350	500	400	500	350
Material	S235JR	16Mo3	1.4301	1.4571	P275NH

## DESIGN VERSIONS

Sliding surfaces (KP):

S – steel

T – PTFE plate with a diameter  $D_t = B - 5$  mm (see 2.10.)

## PERMISSIBLE LOADS

The load-bearing capacity at higher temperatures and for different materials shall satisfy the following equation:  $F_{pt,M}^G = k_{t,M} \times F_p$ , where the correction factor is specified according to table 1.1. (Supports).



## 34-1

Quadruple-pipe-shoe guide with standard or optional heights. The pipe-shoe height can be specified in the interval  $0.5 \times H$  to  $1 \times H$ . Also available in long version.

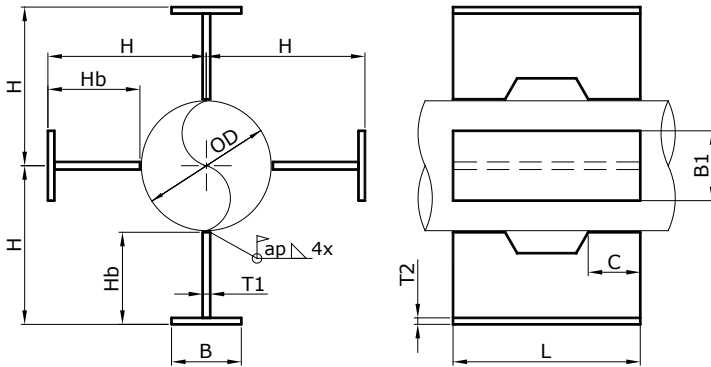

### DESIGNATION

#### 34-1(L) MS-DNK-H-KP

Example of designation: 34-14-125-200-L

DNK – pipe outer diameter code

H – required foot height

MS – material group code

KP – sliding surface code

L – long version, the character is not normally specified

### ASSEMBLY

The support is welded to the pipe with a continuous fillet weld (fillet weld size ap).

### DIMENSIONS AND PARAMETERS

DNK	OD	B	H	L	Hb	ap	T1	T2	C	F	m
mm	mm	mm	mm	mm	mm	mm	mm	mm	mm	mm	kg
015	21,3	30	100	150	88	3	6	6	40	30	3,6
020	26,9	30	100	150	85	3	6	6	40	30	3,5
025	31,8	30	100	150	83	3	6	6	40	30	3,5
025	33,7	30	100	150	82	3	6	6	40	30	3,4
038	38	30	120	150	100	3	6	6	40	30	4,0
032	42,4	30	120	150	97	3	6	6	40	30	3,9
040	48,3	30	120	150	94	3	6	6	40	30	3,8
057	57	40	155	200	125	4	8	8	50	40	8,8
050	60,3	40	155	200	123	4	8	8	50	40	8,7
073	73	40	165	200	127	4	8	8	50	40	8,9
065	76,1	40	165	200	125	4	8	8	50	40	8,8
080	88,9	40	170	200	124	4	8	8	50	40	8,7
108	108	40	200	250	145	4	10	10	65	40	16,1
100	114,3	40	200	250	141	4	10	10	65	40	15,8
127	127	50	220	250	155	4	10	10	65	40	18,4
133	133	50	220	250	152	4	10	10	65	40	18,2
125	139,7	50	220	250	149	4	10	10	65	40	18,0
141	141,3	50	220	250	148	4	10	10	65	40	17,9
159	159	50	240	250	159	4	10	10	65	40	18,8
150	168,3	50	240	250	154	4	10	10	65	40	18,4

Dimension F = 30-50 mm

### MATERIAL GROUPS

MS No.	1	2	4	5	7
Tmax (°C)	350	500	400	500	350
Material	S235JR	16Mo3	1.4301	1.4571	P275NH

### DESIGN VERSIONS

Sliding surfaces (KP):

S – steel

T – PTFE plate with a diameter  $Dt = B - 5$  mm (see 2.10.)

### PERMISSIBLE LOADS

The load-bearing capacity at higher temperatures and for different materials shall satisfy the following equation:  $F_{pt,M}^G = k_{t,M} \times F_p$ , where the correction factor is specified according to table 1.1. (Supports).

## 36-1

Double-pipe-shoe guide with standard or optional heights. The pipe-shoe height can be specified in the interval  $0.5 \times H$  to  $1.2 \times H$ . Also available in long version.

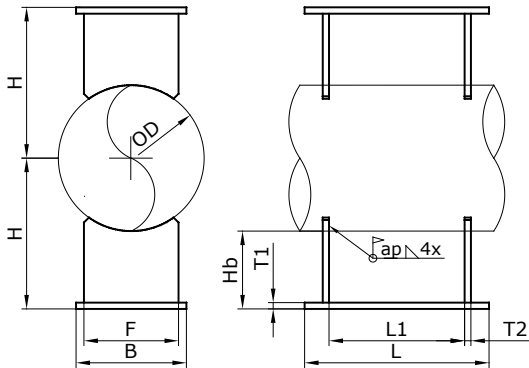

## DIMENSIONS AND PARAMETERS

OD	DNK	H	B	L	Hb	ap	T1	T2	F	L1	Fpy	Fpz	m
mm	mm	mm	mm	mm	mm	mm	mm	mm	mm	mm	kN	kN	kg
57	057	155	80	200	127	3	8	6	50	134	1,8	4,4	3,2
60,3	050	155	80	200	125	3	8	6	50	134	1,8	4,4	3,2
73	073	165	85	200	129	3	8	6	60	134	2,3	5,3	3,6
76,1	065	165	85	200	127	3	8	6	60	134	2,3	5,3	3,6
88,9	080	170	85	200	126	3	8	6	60	134	2,3	5,4	3,6
108	108	200	100	240	146	4	10	8	80	162	4,7	7,9	6,1
114,3	100	200	100	240	143	4	10	8	80	162	4,7	7,9	6,6
127	127	220	120	240	157	4	10	8	100	162	5,9	9,5	8,5
133	133	220	120	240	154	4	10	8	100	162	5,9	9,5	8,4
139,7	125	220	120	240	150	4	10	8	100	162	5,9	9,5	8,3
141,3	141	220	120	240	149	4	10	8	100	162	5,9	9,5	8,3
159	159	240	120	240	161	4	10	8	100	162	5,7	9,5	8,6
168,3	150	240	120	240	156	4	10	8	100	162	5,7	9,5	8,4
193,7	175	270	140	240	173	4	10	8	120	162	6,7	11,1	10,5
219,1	200	290	150	240	180	4	10	8	130	162	7,2	11,9	11,5
244,5	225	300	150	240	178	5	12	10	130	150	10,5	17,1	14,0
273	250	330	165	300	194	5	12	10	145	210	11,1	15,7	18,1
323,9	300	380	190	300	218	5	12	10	170	210	12,1	18,0	22
355,6	350	400	200	300	222	5	12	10	180	210	12,8	19,0	24
377	377	400	200	300	212	5	12	10	180	210	12,8	19,0	23
406,4	400	430	205	350	227	6	15	12	185	248	17,7	26,1	30
426	426	430	205	350	217	6	15	12	185	248	17,7	26,1	32
457	450	470	225	350	242	6	15	12	200	248	18,4	28,6	37
508	500	500	230	350	246	6	15	12	210	248	19,2	29,2	38
530	530	500	230	350	235	6	15	12	210	248	19,2	29,2	38
559	550	530	240	350	251	6	15	12	220	228	20,4	30,5	41
609,6	600	560	255	450	255	6	15	12	225	328	20,6	25,2	49
630	630	560	255	450	245	6	15	12	225	328	20,6	25,2	48
664	650	590	270	450	260	6	20	15	240	325	25,4	38,8	68
711,2	700	630	290	450	275	6	20	15	260	325	30,5	46,7	75
720	720	630	320	450	270	6	20	15	290	325	30,5	46,7	82
762	750	670	340	450	289	6	20	15	310	325	31,5	49,2	90
812,8	800	700	340	450	294	6	20	15	310	325	31,0	48,9	91
820	820	700	340	450	290	6	20	15	310	325	31,0	48,9	90

## MATERIAL GROUPS

MS No.	1	2	4	5	7	6	7
Tmax (°C)	350	500	400	500	350	620	350
Material	S235JR	16Mo3	1.4301	1.4571	P275NH	1.4948	P275NH

## DESIGN VERSIONS

Sliding surfaces (KP): S – steel, M – stainless steel mirror.

Long version – the foot length is 1.5 times longer than the standard length L. Other dimensions remain unchanged; the weight is 1.5 times the tabular value of m.

## DESIGNATION

## 36-1(L) MS-DNK-H-KP

Example of designation: 36-14-150-220

DNK – pipe outer diameter code, H – required foot height, MS – material group code, KP – sliding surface code, L – long design, no character is normally specified.

## ASSEMBLY

The support is welded to the pipe with a continuous fillet weld (fillet weld size ap).

## PERMISSIBLE LOADS

$F_{py}$  – load perpendicular to the pipe-shoe axis (shown horizontally perpendicularly to pipe axis),  $F_{pz}$  – load in the direction of pipe-shoe axis (shown vertically in the picture). Resultant external force must satisfy the following equation for total load:  $F_y/F_p + F_z/F_p \leq 1$ .

The load-bearing capacity at higher temperatures and for different materials shall satisfy the following equation:  $F_{pt,M}^G = k_{L,M} \times F_{pr}$  where the correction factor is specified according to table 1.1. (Supports).

## 36-2

Double-pipe-shoe guide with standard or optional height. The pipe-shoe height can be specified in the interval  $0.5 \times H$  to  $1.2 \times H$ . Also available in long version.

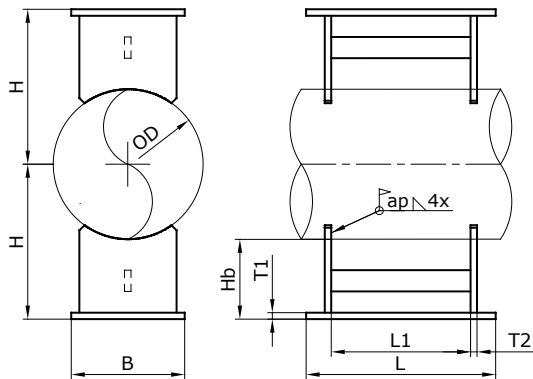

## DIMENSIONS AND PARAMETERS

OD	DNK	H	B	L	Hb	ap	T1	T2	F	L1	Fpy	Fpz	m
mm	mm	mm	mm	mm	mm	mm	mm	mm	mm	mm	kN	kN	kg
57	057	155	80	200	127	3	8	6	50	134	1,8	7,5	5,2
60,3	050	155	80	200	125	3	8	6	50	134	1,8	7,5	5,3
73	073	165	85	200	129	3	8	6	60	134	2,3	9,4	5,8
76,1	065	165	85	200	127	3	8	6	60	134	2,3	9,4	5,8
88,9	080	170	85	200	126	3	8	6	60	134	2,3	9,5	6,0
108	108	200	100	240	146	4	10	8	80	162	4,7	12,9	11,0
114,3	100	200	100	240	143	4	10	8	80	162	4,7	12,9	11,0
127	127	220	120	240	157	4	10	8	100	162	5,9	15,4	13,0
133	133	220	120	240	154	4	10	8	100	162	5,9	15,4	13,1
139,7	125	220	120	240	150	4	10	8	100	162	5,9	15,4	13,1
141,3	141	220	120	240	149	4	10	8	100	162	5,9	15,4	13,2
159	159	240	120	240	161	4	10	8	100	162	5,7	15,4	13,8
168,3	150	240	120	240	156	4	10	8	100	162	5,7	15,4	13,8
193,7	175	270	140	240	173	4	10	8	120	162	6,7	18,0	16,4
219,1	200	290	150	240	180	4	10	8	130	162	7,2	19,3	17,9
244,5	225	300	150	240	178	5	12	10	130	150	10,5	27,8	23,6
273	250	330	165	300	194	5	12	10	145	210	11,1	21,5	29,7
323,9	300	380	190	300	218	5	12	10	170	210	12,1	24,8	35
355,6	350	400	200	300	222	5	12	10	180	210	12,8	26,1	37
377	377	400	200	300	212	5	12	10	180	210	12,8	26,1	37
406,4	400	430	205	350	227	6	15	12	185	248	17,7	32,1	55
426	426	430	205	350	217	6	15	12	185	248	17,7	32,1	55
457	450	470	225	350	242	6	15	12	200	248	18,4	35,2	60
508	500	500	230	350	246	6	15	12	210	248	19,2	36,0	64
530	530	500	230	350	235	6	15	12	210	248	19,2	36,0	64
559	550	530	240	350	251	6	15	12	220	228	20,4	37,5	90
609,6	600	560	255	450	255	6	15	12	225	328	20,6	27,0	103
630	630	560	255	450	245	6	15	12	225	328	20,6	27,0	106
664	650	590	270	450	260	6	20	15	240	325	25,4	50,8	130
711,2	700	630	290	450	275	6	20	15	260	325	30,5	60,2	140
720	720	630	320	450	270	6	20	15	290	325	30,5	60,2	148
762	750	670	340	450	289	6	20	15	310	325	31,5	64,0	159
812,8	800	700	340	450	294	6	20	15	310	325	31,0	64,0	163
820	820	700	340	450	290	6	20	15	310	325	31,0	64,0	163

## MATERIAL GROUPS

MS No.	1	2	4	5	7	6	7
Tmax (°C)	350	500	400	500	350	620	350
Material	S235JR	16Mo3	1.4301	1.4571	P275NH	1.4948	P275NH

## DESIGN VERSIONS

Sliding surfaces (KP): S – steel, M – stainless steel mirror.  
Long version – the foot length is 1.5 times longer than the standard length L. Other dimensions remain unchanged; the weight is 1.5 times the tabular value of m.

## DESIGNATION

## 36-2(L) MS-DNK-H-KP

Example of designation: 36-27-530-500-M

DNK – pipe outer diameter code, H – required foot height, MS – material group code, KP – sliding surface code, L – long design, no character is normally specified.

## ASSEMBLY

The support is welded to the pipe with a continuous fillet weld (fillet weld size ap).

## PERMISSIBLE LOADS

$F_{py}$  – load perpendicular to the pipe-shoe axis (shown horizontally perpendicularly to pipe axis),  $F_{pz}$  – load in the direction of pipe-shoe axis (shown vertically in the picture). Resultant external force must satisfy the following equation for total load:  $F_y/F_p + F_z/F_p \leq 1$ .

The load-bearing capacity at higher temperatures and for different materials shall satisfy the following equation:  $F_{pt,M}^G = k_{t,M} \times F_p$ , where the correction factor is specified according to table 1.1. (Supports).

## 37-1

Triple-pipe-shoe guide with standard and optional height. The pipe-shoe height can be specified in the interval  $0.5 \times H$  to  $1.2 \times H$ . Also available in long version.

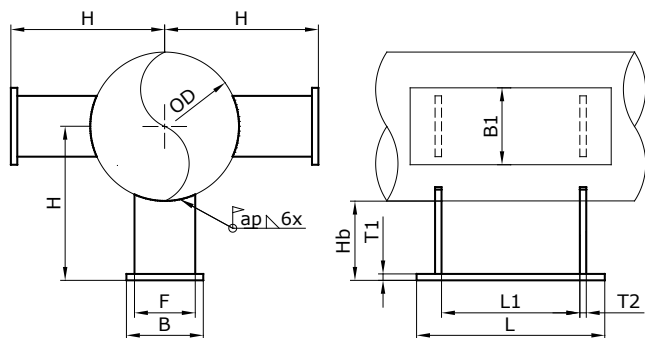

## DESIGNATION

## 37-1(L) MS-DNK-H-KP

Example of designation: 37-1L2-350-400

DNK – pipe outer diameter code, H – required foot height, MS – material group code, KP – sliding surface code, L – long design, no character is normally specified.

## ASSEMBLY

The support is welded to the pipe with a continuous fillet weld (fillet weld size ap).

## DIMENSIONS AND PARAMETERS

OD	DNK	H	B=B1	L	Hb	ap	T1	T2	F	L1	Fp	m
mm	mm	mm	mm	mm	mm	mm	mm	mm	mm	mm	kN	kg
108	108	200	80	240	146	4	10	8	55	162	5,2	7,5
114,3	100	200	80	240	143	4	10	8	55	162	5,2	7,5
127	127	220	80	240	157	4	10	8	70	162	6,6	8,6
133	133	220	80	240	154	4	10	8	70	162	6,6	8,6
139,7	125	220	80	240	150	4	10	8	70	162	6,6	8,5
141,3	141	220	80	240	149	4	10	8	70	162	6,6	8,5
159	159	240	100	240	161	4	10	8	85	162	8,1	10,8
168,3	150	240	100	240	156	4	10	8	85	162	8,1	10,6
193,7	175	270	100	240	173	4	10	8	95	162	8,8	11,9
219,1	200	290	120	240	180	4	10	8	110	162	10,2	14,3
244,5	225	300	130	240	178	5	12	10	120	150	16,7	18,9
273	250	330	140	300	194	5	12	10	130	210	16,3	24
323,9	300	380	170	300	218	5	12	10	160	210	19,5	31
355,6	350	400	180	300	222	5	12	10	175	210	21,4	34
377	377	400	180	300	212	5	12	10	175	210	21,4	33
406,4	400	430	200	350	227	6	15	12	190	248	29,9	49
426	426	430	200	350	217	6	15	12	190	248	29,9	48
457	450	470	200	350	242	6	15	12	190	248	29,1	51
508	500	500	200	350	246	6	15	12	190	248	28,9	51
530	530	500	200	350	235	6	15	12	190	248	28,9	50
559	550	530	200	350	251	6	15	12	190	228	28,9	52
609,6	600	560	230	450	255	6	15	12	220	328	30,0	68
630	630	560	230	450	245	6	15	12	220	328	30,0	67
664	650	590	230	450	260	6	20	15	220	325	35,2	89
711,2	700	630	250	450	275	6	20	15	240	325	37,9	100
720	720	630	250	450	270	6	20	15	240	325	37,9	99
762	750	670	250	450	289	6	20	15	240	325	37,2	102
812,8	800	700	250	450	294	6	20	15	240	325	36,9	103
820	820	700	250	450	290	6	20	15	240	325	36,9	102

## MATERIAL GROUPS

MS No.	1	2	4	5	7	6	7
Tmax (°C)	350	500	400	500	350	620	350
Material	S235JR	16Mo3	1.4301	1.4571	P275NH	1.4948	P275NH

## PERMISSIBLE LOADS

The load-bearing capacity at higher temperatures and for different materials shall satisfy the following equation:  $F_{pt,M}^G = k_{t,M} \times F_p$ , where the correction factor is specified according to table 1.1. (Supports).

## DESIGN VERSIONS

Sliding surfaces (KP):

S – steel

M – stainless steel mirror

T – PTFE plate with a diameter  $D_t = B - 5$  mm (see 2.10.)

Long version – the foot length is 1.5 times longer than the standard length L. Other dimensions remain unchanged; the weight is 1.5 times the tabular value of m.

## 37-2

Triple-pipe-shoe guide with standard and optional height. The pipe-shoe height can be specified in the interval  $0.5 \times H$  to  $1.2 \times H$ . Also available in long version.

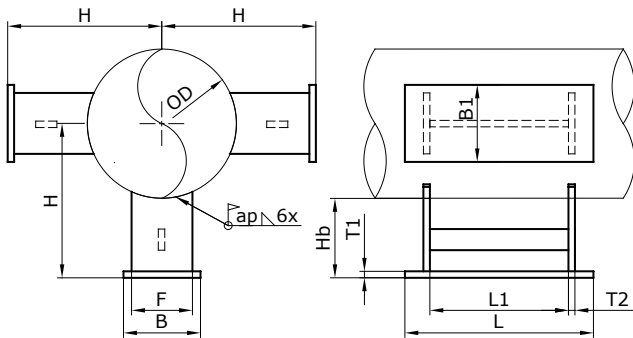

## DESIGNATION

## 37-2(L) MS-DNK-H-KP

Example of designation: 37-25-175-280-T

DNK – pipe outer diameter code, H – required foot height, MS – material group code, KP – sliding surface code, L – long design, no character is normally specified.

## ASSEMBLY

The support is welded to the pipe with a continuous fillet weld (fillet weld size ap).

## DIMENSIONS AND PARAMETERS

OD	DNK	H	B=B1	L	Hb	ap	T1	T2	F	L1	Fp	m
mm	mm	mm	mm	mm	mm	mm	mm	mm	mm	mm	kN	kg
108	108	200	80	240	146	4	10	8	55	162	8,9	8,8
114,3	100	200	80	240	143	4	10	8	55	162	8,9	8,7
127	127	220	80	240	157	4	10	8	70	162	11,4	9,9
133	133	220	80	240	154	4	10	8	70	162	11,4	9,8
139,7	125	220	80	240	150	4	10	8	70	162	11,4	9,7
141,3	141	220	80	240	149	4	10	8	70	162	11,4	9,7
159	159	240	100	240	161	4	10	8	85	162	14,2	12,3
168,3	150	240	100	240	156	4	10	8	85	162	14,2	12,2
193,7	175	270	100	240	173	4	10	8	95	162	15,4	13,4
219,1	200	290	120	240	180	4	10	8	110	162	17,8	15,8
244,5	225	300	130	240	178	5	12	10	120	150	27,8	21
273	250	330	140	300	194	5	12	10	130	210	21,5	27
323,9	300	380	170	300	218	5	12	10	160	210	24,8	34
355,6	350	400	180	300	222	5	12	10	175	210	26,1	37
377	377	400	180	300	212	5	12	10	175	210	26,1	36
406,4	400	430	200	350	227	6	15	12	190	248	32,1	53
426	426	430	200	350	217	6	15	12	190	248	32,1	52
457	450	470	200	350	242	6	15	12	190	248	35,2	55
508	500	500	200	350	246	6	15	12	190	248	36,0	57
530	530	500	200	350	235	6	15	12	190	248	36,0	56
559	550	530	200	350	251	6	15	12	190	228	37,5	57
609,6	600	560	230	450	255	6	15	12	220	328	48,0	76
630	630	560	230	450	245	6	15	12	220	328	48,0	74
664	650	590	230	450	260	6	20	15	220	325	50,8	98
711,2	700	630	250	450	275	6	20	15	240	325	60,2	111
720	720	630	250	450	270	6	20	15	240	325	60,2	110
762	750	670	250	450	289	6	20	15	240	325	64,0	113
812,8	800	700	250	450	294	6	20	15	240	325	64,0	114
820	820	700	250	450	290	6	20	15	240	325	64,0	114

## MATERIAL GROUPS

MS No.	1	2	4	5	7	6	7
Tmax (°C)	350	500	400	500	350	620	350
Material	S235JR	16Mo3	1.4301	1.4571	P275NH	1.4948	P275NH

## PERMISSIBLE LOADS

The load-bearing capacity at higher temperatures and for different materials shall satisfy the following equation:

$F_{pt,M}^G = k_{t,M} \times F_p$ , where the correction factor is specified according to table 1.1. (Supports).

## DESIGN VERSIONS

Sliding surfaces (KP):

S – steel

M – stainless steel mirror

T – PTFE plate with a diameter  $D_t = B - 5$  mm (see 2.10.)

Long version – the foot length is 1.5 times longer than the standard length L. Other dimensions remain unchanged; the weight is 1.5 times the tabular value of m.

3

# ATTACHMENT PARTS: CLAMPS, LUGS AND U-BOLTS



### 3.1. USE

Pipe attachment parts are designed for transfer of forces from the surface of a horizontal or vertical pipe to hanger rods. Permissible angular deflection of hanger rods from vertical axis is max. 4°.

In terms of the pipe attachments parts there two following groups:

- Clamps or U-bolts (C)
- Weld-on eyes or trunnions (W)

All clamps and U-bolts are assembled without assembly welding. Riser clamps (clamps for vertical piping) with outer diameter OD  $\geq 88.9$  mm require the pipe to be secured against slipping by an element welded to the pipe wall. Clamps for horizontal piping are safely attached to the pipe by force friction connection between the clamp and the pipe.

The following principles should be followed for the selection of the pipe attachment elements:

- Crevice corrosion occurs in the gap between a pipe clamp and pipe wall. Therefore, it is advisable to use welding attachments in aggressive environments;
- Clamps and U-bolts allow the pipe support to be relocated to its desired position multiple times;
- Weld-on eyes are considerably more economical and lighter;
- Weld-on eyes are not suitable for piping with high working temperatures (above 350 °C), because of the risk of cracking due to cyclic stresses from temperature gradients.

### 3.2 DESIGN OF PIPE ATTACHMENT PARTS

#### a) Light pipe clamps for horizontal and vertical pipes (types 41, 42, 43)

They consist of two half-clamps made of strip steel, which are joined together with bolts. In the end part, there is a pin or a bolt with a smooth shaft to which the eye nut of the rod is attached. The pin diameter is selected according to the diameter of hanger rod. It is possible to use a pin diameter one size larger than the eye nut diameter.

Main application characteristics:

- Transfer of low and medium loads;
- The rod diameter must be selected according to diameter of the structural attachment element (see 4.1.);
- They are designed for pipes calibrated to outside diameter;
- They have relatively low rigidity – they can deform under a load and a deformation may occur at the restraint;
- The material group of the clamps must be similar and compatible to pipe material.

The clamps can only be used for pipes with tolerance of outer pipe diameter up to 1%. For larger outer diameter tolerances (e.g. pipes calibrated to inner diameter), pipe clamps with U-bolts must be used. Longitudinal welds of welded pipes may not protrude out of the pipe surface by more than 1 mm at the point of the contact with the pipe clamp.

List of clamp types:

Description	Type	Use
Light two-bolt clamps	41-C1	Low loads, uninsulated horizontal pipes
Light three-bolt clamps	42-C1	Low loads, insulated horizontal pipes
Reinforced three-bolt clamps	42-C2	Higher loads, insulated horizontal pipes
Riser clamp	43-C1	Low and medium load, vertical pipes
Pipe clip	47-C1	Low load, horizontal and vertical pipes of small diameters, flexible connection

Attachments for support bases and rigid struts are described in section 2 and 8 of this catalogue.

General principles for selecting the attachment type and dimensions:

- Insulation thickness – the top pin attached to the hanger rod must always be outside the insulation and at least 30 mm above the surface of insulation, local reduction of the insulation thickness by 20% is allowed;
- For stainless steel pipes with operating temperature up to 230 °C, carbon steel clamps lined with PTFE foil can be used;
- Riser clamps for piping of DN  $\geq 150$  with operating temperature above 500 °C shall be secured with trunnions welded to the pipe;
- Riser clamps for piping of DN  $\geq 80$  must always be secured against slipping by shear lugs;
- The shear lugs must be of the same material group as the pipe material, both in terms of weldability and mechanical properties.

The diameter of a connecting element (diameter of bolt, or pin or hole) is selected on the basis of design load of one hanger rod. For riser clamps (double-rod hangers), it is selected as follows:

- For rod or spring hangers with clamps or clamps with U-bolts, 0.7 times the total load of the hanger for all load combinations;
- For rod or spring hangers with a weld-on attachments, 1.0 time the total load of the hanger for all load combinations.

#### b) Pipe clamps type 44 and riser clamps type 45

Pipe clamps (type 44 and 45) are a multi-component device that is assembled during the assembly of piping system. Connection to hanger rod is realized through a clevis with pin.

Horizontal pipe clamps (type 44) consist of a U-bolt that wraps the pipe around, the U-bolts are lined with a base plate, and they are connected to steel structure beam via a weld-on eye or a clevis with pin.

Riser clamps (type 45) consist of main beams, that are attached to pipe via two weld-on trunnions, and side beams to which the hanger rod is attached.

Main application characteristics:

- Transfer of medium and high load;
- Use at high piping operating temperatures;
- Application for all types of pipes, also for those calibrated to internal diameter;
- Special clamp models may be designed for inclined pipes upon request.

The clamps (type 44 and 45) and U-bolts (type 46) may be used for pipes with the outer diameter tolerance up to 2,5%. If the tolerance of outer pipe diameter is greater than 1% then it must be specified in the order.

List of clamps types:

Description	Type	Use
Pipe clamp for horizontal pipe	44-C	High loads and temperatures, insulated / uninsulated pipes
Riser clamps	45-C	High loads and temperatures, insulated / uninsulated pipes
U-bolts	46	Uninsulated pipes laid directly on steel structure beams



**c) Weld-on pipe attachment parts for horizontal and vertical pipes**

For attachment of horizontal pipes, flat weld-on lugs are used. The lugs are welded on the pipe with continuous fillet weld. The lugs have a hole for a clevis with a pin through which they are connected to hanger rods.

The hole in the lug must be outside, the distance of the hole axis from the surface of the insulation shall be equal to at least two hole diameters.

For attachment of vertical pipes weld-on trunnions are used. The trunnions have a flat structural attachment at the end with a hole for a clevis with a pin through which they are connected to hanger rods. The trunnions are welded to the pipe with full penetration welds.

Main application characteristics:

- Elimination of crevice corrosion;
- Use especially for outdoor uninsulated pipes or insulated pipes, which are operated only occasionally;
- Simple design;
- Transfer of medium and high loads;
- High rigidity of the pipe attachment element;
- The material of the lugs and trunnions must be similar to the pipe material.

List of weld-on pipe attachment parts:

Description	Type	Use
Weld-on lug for horizontal pipes	41-W	Temperatures up to 350 °C, insulated / uninsulated pipes
Weld-on lug for bends	42-W	Temperatures up to 350 °C, insulated / uninsulated pipes
Welding trunnion for vertical pipes	45-W	Temperatures up to 350 °C, insulated / uninsulated pipes

**3.4 LOAD-BEARING CAPACITY OF CLAMPS AND U-BOLTS**

The permissible load  $F_p$  relate to the tensile load in the direction hanger rod (with a permissible deflection of 4° from vertical direction).

The values of comparative loads  $F_p$ , stated in the tables of the

Table 3.1 – Correction factors for permissible loads at the temperature  $kT$ , M (-) for types 41, 42, 43 and 78:

MS / T (°C)	80	100	150	200	250	300	350	400	450	480	490	500	510	520	530	540	550	560	570	580	600	
1	1,00	0,95	0,90	0,85	0,76	0,62	0,55															
2	1,22	1,21	1,14	1,07	0,97	0,89	0,84	0,80	0,73	0,67	0,66	0,58	0,46	0,38	0,30	0,25						
3									0,97	0,90	0,83	0,75	0,66	0,58	0,50	0,43	0,37	0,32	0,27	0,24		
4	0,98	0,87	0,79	0,72	0,66	0,62	0,60	0,59	0,57													
5	1,01	0,95	0,90	0,85	0,81	0,76	0,75	0,74	0,71	0,70	0,69	0,68	0,68									
6									0,58	0,56	0,55	0,54	0,54	0,53	0,53	0,52	0,52	0,52	0,51	0,50	0,50	
7	1,12	1,12	1,06	0,97	0,89	0,82	0,78	0,76	0,71													

Table 3.2 – Correction factors for permissible loads at the temperature  $kT$ , M (-) for type 44:

MS / T (°C)	80	100	150	200	250	300	350	400	450	480	490	500	510	520	530	540	550	560	
1	1,00	1,00	0,91	0,87	0,81	0,68	0,55												
2					1,00	0,92	0,83	0,76	0,72	0,66	0,63	0,60	0,55	0,49					
3								1,02	0,91	0,82	0,78	0,74	0,70	0,65	0,60	0,55	0,49	0,43	
4	0,73	0,73	0,62	0,55	0,50	0,47	0,45	0,43											
5	0,75	0,75	0,69	0,65	0,61	0,58	0,56	0,54	0,53	0,53	0,52	0,52							
7	1,17	1,17	1,10	1,01	0,93	0,85	0,79	0,73											
7	1,12	1,12	1,06	0,97	0,89	0,82	0,78	0,76	0,71										

**3.3 DESIGN LOAD AND DESIGN TEMPERATURE**

The design load of the pipe attachment parts for permanent load is calculated according to this formula:  $F_d^T = 1.0 \times F_a^T$ , where the index T indicates the temperature combinations of analysed operating conditions acting simultaneously with the load.  $F_a$  is the load on relevant restraint taken from the piping stress analysis. Only the vertical component is considered for pipe shoes, the frictional forces are included in the permissible support load  $F_p$  listed in the tables. For guided pipe shoes, stops and anchors, all force components in the directions of limited movement are considered.

The design temperature  $T_d$  is equal to the maximum allowable temperature of the piping without allowances.

The design temperature  $T_d$  must be specified by the customer, according to the procedure:

- For temperatures below the creep range, (< 450 °C) -  $T_d$  is equal to the maximum allowable temperature of the piping,
- For temperatures in the creep range (approximately above 450 °C) -  $T_d$  is equal to the average operating pipe temperature of the most frequent cycle, if the difference between the maximum and the minimum temperature of the cycle is not greater than 10 °C, or
- The maximum allowable pipe temperature without temperature allowances (reserve), specified by relevant standards.

data sheets, are established for the basic design temperature of 80 °C and for the structural attachment manufacture from material group (MS) 1 and the load category G. The load-bearing capacity at higher temperatures and for other materials shall be obtained using the following formulas:  $F_{p^T M} = k_{t^T M} \times F_p$ , where the correction factor  $k_t$  is listed in Tables 3.1 to 3.3.



Table 3.3 – Correction factors for permissible loads at the temperature kT, M (-) for type 45:

MS / T (°C)	80	100	150	200	250	300	350	400	450	480	490	500	510	520	530	540	550	560	570	580	600
1	1,00	1,00	1,00	1,00	1,00	0,94	0,83														
2	1,00	1,00	1,00	1,00	1,00	1,00	1,00	1,00	1,00	1,00	0,98	0,86	0,69	0,57	0,45	0,37					
3									1,00	1,00	1,00	1,00	0,99	0,86	0,75	0,65	0,56	0,48	0,41		
4	1,00	1,00	1,00	1,00	1,00	0,93	0,90	0,89	0,86												
5	1,00	1,00	1,00	1,00	1,00	1,00	1,00	1,00	1,00	1,00	1,00	1,00	1,00								
6								0,87	0,84	0,83	0,81	0,81	0,80	0,80	0,78	0,78	0,78	0,77	0,75	0,75	0,65
7	1,00	1,00	1,00	1,00	1,00	1,00	1,00	1,00	1,00												

For occasional loads of category Q, the conversion shall be as follows:  $F_{p'Q} = 1.2 \times F_{p'G}$ .

### 3.5 SURFACE FINISH

The following factors must be considered when specifying the surface finish:

- Welding or clamped design of pipe attachments;
- A suitable shop primer, compatible with the assembly topcoat, must be specified for the weld-on lugs or trunnions;
- Corrosive aggressiveness of the environment and required service life of surface finish;
- Temperature effect;
- Effect of surface finish on the sliding surface.

Clamps and U-bolts made of carbon steel (material groups 1, 2 and 7) are supplied with a primer or topcoat as a standard. Requirements for galvanizing or hot-dip galvanizing of the clamps of material group 1 for temperatures up to 200 °C must be specified in the order.

Weld-on lugs or trunnions, made of carbon steel, are supplied with a primer or topcoat, as a standard.

Clamps and U-bolts made of alloy steel (material group 3) are supplied with a primer.

Stainless steel clamps (material groups 4, 5, 6) are supplied without a surface finish.

### 41-1

Clamp for hangers of horizontal non-insulated piping. Connection to hanger rod via eye nut.

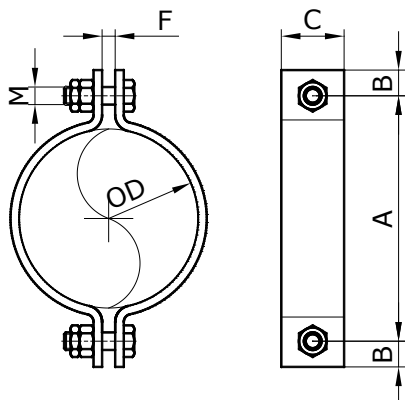

#### DESIGNATION

##### 41-1 MS-DNK

Example of designation: 41-15-350

DNK – pipe outer diameter code

MS – material group code

#### ASSEMBLY

The clamp is assembled by bolting the half-clamps together, the clamp bolts are to be hand-tightened until the half-clamps are in full contact with the pipe and then the bolts are to be tightened by further 180° using a wrench.

#### DIMENSIONS AND PARAMETERS

OD	DNK	A	B	C	F	M	Fp	m
mm	mm	mm	mm	mm	mm	mm	kN	kg
21,3	015	52	15	30	7	10	2,9	0,25
26,9	020	60	15	30	7	10	2,9	0,27
31,8	025	68	15	30	7	10	2,9	0,30
33,7	025	69	15	30	7	10	2,9	0,30
38	038	74	15	30	7	10	2,9	0,32
42,4	032	80	15	30	7	10	2,9	0,33
48,3	040	86	15	30	7	10	2,9	0,35
57	057	100	18	40	9	12	5,8	0,66
60,3	050	104	18	40	9	12	5,8	0,68
73	073	118	18	40	9	12	5,8	0,76
76,1	065	122	18	40	9	12	5,8	0,78
88,9	080	136	18	40	9	12	5,8	0,85
108	108	172	24	50	11	16	14,0	1,40
114,3	100	178	24	50	11	16	14,0	1,45
127	127	192	24	50	11	16	14,0	1,58
133	133	198	24	50	11	16	14,0	1,64
139,7	125	204	24	50	11	16	13,8	1,70
141,3	141	208	24	50	11	16	13,6	1,73
159	159	226	24	50	11	16	11,9	1,90
168,3	150	236	24	50	11	16	11,2	1,99
193,7	175	262	24	50	11	16	9,7	2,2
219,1	200	288	24	50	11	16	8,5	2,5
244,5	225	322	30	60	17	20	9,3	4,0
273	250	350	30	60	17	20	8,3	4,3
323,9	300	403	30	60	17	20	6,9	4,9
355,6	350	434	30	60	17	20	6,3	5,3
377	377	456	30	60	17	20	5,9	5,5
406,4	400	502	36	70	23	24	10,0	9,0
426	426	522	36	70	23	24	9,5	9,3
457	450	554	36	70	23	24	8,8	9,8
508	500	606	36	70	23	24	7,9	10,7
530	530	628	36	70	23	24	7,6	11,1
559	550	692	45	90	28	30	20,7	23,0
609,6	600	744	45	90	28	30	18,9	24,7
630	630	764	45	90	28	30	18,3	25,3
664	650	800	45	90	28	30	17,4	26,5
711,2	700	845	45	90	28	30	16,1	28,0
720	720	855	45	90	28	30	15,9	28,3
762	750	900	45	90	28	30	15,0	29,8
812,8	800	950	45	90	30	30	14,1	31,5
820	820	960	45	90	30	30	14,0	31,8

#### MATERIAL GROUPS

MS No.	1	4	7
Tmax (°C)	350	400	350
Material	S235JR	1.4301	P275NH

#### PERMISSIBLE LOADS

The load-bearing capacity at higher temperatures and for different materials shall satisfy the following equation:  $F_{Dt,M}^G = k_{t,M} \times F_p$ , where the correction factor is specified according to table 31.

42-1

Light clamp for hangers of horizontal piping. Connection to hanger rod via eye nut.

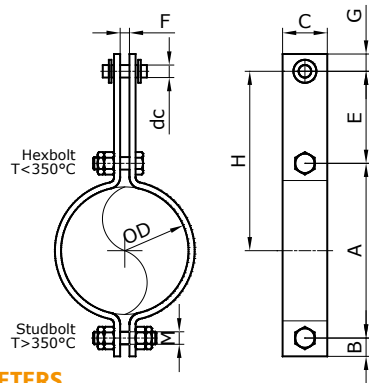

DIMENSIONS AND PARAMETERS

OD	DNK	H	A	B	C	E	F	G	M	dc	Fp	m
mm	mm	mm	mm	mm	mm	mm	mm	mm	mm	mm	kN	kg
21,3	015	72	52	15	30	46	7	17	10	10	2,9	0,45
26,9	020	76	60	15	30	46	7	17	10	10	2,9	0,47
31,8	025	80	68	15	30	46	7	17	10	10	2,9	0,49
33,7	025	80,5	69	15	30	46	7	17	10	10	2,9	0,49
38	038	83	74	15	30	46	7	17	10	10	2,9	0,51
42,4	032	86	80	15	30	46	7	17	10	10	2,9	0,53
48,3	040	89	86	15	30	46	7	17	10	10	2,9	0,55
57	057	104	100	18	40	54	9	20	12	12	5,8	1,03
60,3	050	106	104	18	40	54	9	20	12	12	5,8	1,05
73	073	113	118	18	40	54	9	20	12	12	5,8	1,12
76,1	065	115	122	18	40	54	9	20	12	12	5,8	1,14
88,9	080	122	136	18	40	54	9	20	12	12	5,8	1,22
108	108	156	172	24	50	70	11	28	16	16	14,0	2,21
114,3	100	159	178	24	50	70	11	28	16	16	14,0	2,27
127	127	166	192	24	50	70	11	28	16	16	14,0	2,40
133	133	169	198	24	50	70	11	28	16	16	14,0	2,45
139,7	125	172	204	24	50	70	11	28	16	16	13,8	2,51
141,3	141	174	208	24	50	70	11	28	16	16	13,6	2,54
159	159	183	226	24	50	70	11	28	16	16	11,9	2,71
168,3	150	188	236	24	50	70	11	28	16	16	11,2	2,81
193,7	175	201	262	24	50	70	11	28	16	16	9,7	3,1
219,1	200	214	288	24	50	70	11	28	16	16	8,5	3,3
244,5	225	247	322	30	60	86	17	36	20	20	9,3	5,2
273	250	261	350	30	60	86	17	36	20	20	8,3	5,6
323,9	300	287,5	403	30	60	86	17	36	20	20	6,9	6,2
355,6	350	303	434	30	60	86	17	36	20	20	6,3	6,5
377	377	314	456	30	60	86	17	36	20	20	5,9	6,8
406,4	400	355	502	36	70	104	23	44	24	24	10,0	11,2
426	426	365	522	36	70	104	23	44	24	24	9,5	11,5
457	450	381	554	36	70	104	23	44	24	24	8,8	12,0
508	500	407	606	36	70	104	23	44	24	24	7,9	12,9
530	530	418	628	36	70	104	23	44	24	24	7,6	13,3
559	550	461	692	45	90	115	28	56	30	33	20,7	28,0
609,6	600	487	744	45	90	115	28	56	30	33	18,9	29,7
630	630	497	764	45	90	115	28	56	30	33	18,3	30,4
664	650	515	800	45	90	115	28	56	30	33	17,4	31,6
711,2	700	537,5	845	45	90	115	28	56	30	33	16,1	33,1
720	720	542,5	855	45	90	115	28	56	30	33	15,9	33,4
762	750	565	900	45	90	115	28	56	30	33	15,0	34,8
812,8	800	590	950	45	90	115	30	56	30	33	14,1	36,5
820	820	595	960	45	90	115	30	56	30	33	14,0	36,8

The H dimension shown in the table is the height of a standard clamp. Depending on the insulation thickness and a possible requirement for a shorter length of the hanger, the height H can be specified in the following ranges:

DN	Hmin	Hmax
15-40	Htab-E/3	Htab+40
50-80	Htab-E/3	Htab+50
100-200	Htab-E/3	Htab+70
250-350	Htab-E/3	Htab+80
400-500	Htab-E/3	Htab+90
550-800	Htab-E/3	Htab+100

DESIGNATION

42-1 MS-DNK-(H)

Example of designation: 42-12-141

DNK – pipe outer diameter code

MS – material group code

H – required H dimension (no need to specify when standard clamp is required)

ASSEMBLY

The clamp is assembled by bolting the half-clamps together, the clamp bolts are to be hand-tightened until the half-clamps are in full contact with the pipe and then the bolts are to be tightened by further 180° using a wrench.

MATERIAL GROUPS

MS No.	1	2	3	4	5	6	7
Tmax (°C)	350	500	580	400	500	620	350
Material	S235JR	16Mo3	10CrMo910	1.4301	1.4571	1.4948	P275NH

PERMISSIBLE LOADS

The load-bearing capacity at higher temperatures and for different materials shall satisfy the following equation:  $F_{pt,M}^G = k_{t,M} \times F_p$ , where the correction factor is specified according to table 3.1.

## 42-2

Medium load capacity clamp for hangers of horizontal piping.  
Connection to hanger rod via eye nut.

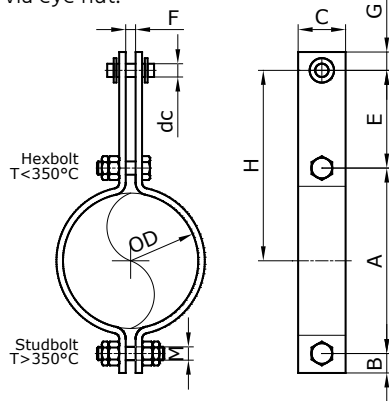

## DIMENSIONS AND PARAMETERS

OD	DNK	H	A	B	C	E	F	G	M	dc	Fp	m
mm	mm	mm	mm	mm	mm	mm	mm	mm	mm	mm	kN	kg
57	057	152	103	18	40	100	9	20	12	12	8,5	1,55
60,3	050	154	107	18	40	100	9	20	12	12	8,5	1,57
73	073	161	122	18	40	100	9	20	12	12	8,5	1,68
76,1	065	163	125	18	40	100	9	20	12	12	8,5	1,70
88,9	080	170	139	18	40	100	9	20	12	12	8,5	1,80
108	108	236	172	24	50	150	11	28	16	16	16,6	3,4
114,3	100	240	179	24	50	150	11	28	16	16	16,6	3,5
127	127	247	193	24	50	150	11	28	16	16	16,6	3,6
133	133	250	199	24	50	150	11	28	16	16	16,6	3,7
139,7	125	253	206	24	50	150	11	28	16	16	16,6	3,8
141,3	141	254	208	24	50	150	11	28	16	16	16,6	3,8
159	159	274	227	24	50	160	11	28	16	16	16,6	4,1
168,3	150	279	237	24	50	160	11	28	16	16	16,6	4,2
193,7	175	312	263	24	50	180	11	28	16	16	15,2	4,7
219,1	200	365	289	24	50	220	11	28	16	16	13,3	5,3
244,5	225	383	325	30	60	220	17	36	20	20	14,7	7,6
273	250	418	355	30	60	240	17	36	20	20	13,0	8,2
323,9	300	444	407	30	60	240	17	36	20	20	10,9	9,0
355,6	350	460	439	30	60	240	17	36	20	20	9,9	9,5
377	377	481	461	30	60	250	17	36	20	20	9,3	9,9
406,4	400	505	510	36	70	250	23	44	24	24	22,8	18,6
426	426	516	531	36	70	250	23	44	24	24	21,7	19,1
457	450	531	562	36	70	250	23	44	24	24	20,2	19,9
508	500	557	614	36	70	250	23	44	24	24	18,1	21,2
530	530	568	636	36	70	250	23	44	24	24	17,3	21,8
559	550	598	695	45	100	250	28	56	30	33	41,9	44,5
609,6	600	623	746	45	100	250	28	56	30	33	38,3	47,0
630	630	634	767	45	100	250	28	56	30	33	37,0	48,0
664	660	651	802	45	100	250	28	56	30	33	35,2	49,7
711,2	700	675	850	45	100	250	28	56	30	33	32,6	52,0
720	720	680	859	45	100	250	28	56	30	33	32,2	52,4
762	750	701	901	45	100	250	28	56	30	33	30,4	54,5
812,8	800	726	952	45	100	250	30	56	30	33	28,5	57,0
820	820	730	959	45	100	250	30	56	30	33	28,2	57,3

The H dimension shown in the table is the height of a standard clamp. Depending on the insulation thickness and a possible requirement for a shorter length of the hanger, the height H can be specified in the following ranges:

DN	Hmin	Hmax
15-40	Htab-E/3	Htab+40
50-80	Htab-E/3	Htab+50
100-200	Htab-E/3	Htab+70
250-350	Htab-E/3	Htab+80
400-500	Htab-E/3	Htab+90
550-800	Htab-E/3	Htab+100

## DESIGNATION

## 42-2 MS-DNK-(H)

Example of designation: 42-24-200-380

DNK – pipe outer diameter code

MS – material group code

H – required H dimension (not specified when selecting the standard)

## ASSEMBLY

The clamp is assembled by bolting the half-clamps together, the clamp bolts are to be hand-tightened until the half-clamps are in full contact with the pipe and then the bolts are to be tightened by further 180° using a wrench.

## MATERIAL GROUPS

MS No.	1	2	3	4	5	6	7
Tmax (°C)	350	500	580	400	500	620	350
Material	S235JR	16Mo3	10CrMo910	1.4301	1.4571	1.4948	P275NH

## PERMISSIBLE LOADS

The load-bearing capacity at higher temperatures and for different materials shall satisfy the following equation:  $F_{pt,M}^G = k_{t,M} \times F_p$ , where the correction factor is specified according to table 3.1.

43-1

Light riser clamp for pipe hangers, connection to hanger rod via eye nut. Shear lugs are included.

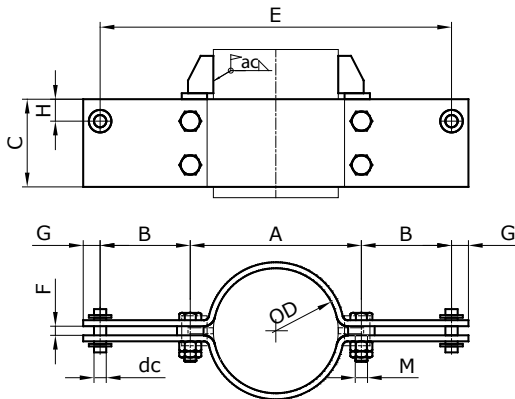

DESIGNATION

43-1 MS-DNK-E

Example of designation: 43-11-530-996

DNK – pipe outer diameter code

MS – material group code

H – required H dimension (not specified when selecting the standard)

ASSEMBLY

After the shear lugs have been welded on to the pipe, the clamp is assembled by bolting the half-clamps together, the clamp bolts are to be hand-tightened until the half-clamps are in full contact with the pipe and then the bolts are to be tightened by further 180° using a wrench.

DIMENSIONS AND PARAMETERS

OD	DN-K	Enom	dc	A	C	Bnom	F	G	H	M	Fp	m
mm	mm	mm	mm	mm	mm	mm	mm	mm	mm	mm	kN	kg
21,3	015	250	12	52	50	99	7	19,6	25	10	3,9	1,27
26,9	020	250	12	60	50	95	7	19,6	25	10	3,4	1,28
31,8	025	252	12	70	50	91	7	19,6	25	12	3,2	1,39
33,7	025	256	12	74	50	91	7	19,6	25	12	3,2	1,41
38	038	306	12	78	50	114	7	19,6	25	12	2,6	1,61
42,4	032	308	12	84	50	112	7	19,6	25	12	2,5	1,62
48,3	040	307	12	91	50	108	7	19,6	25	12	2,5	1,63
57	057	354	12	104	80	125	9	19,6	40	12	9,2	4,3
60,3	050	356	12	108	80	124	9	19,6	40	12	9,2	4,4
73	073	356	12	122	80	117	9	19,6	40	12	9,1	4,4
76,1	065	356	12	126	80	115	9	19,6	40	12	9,1	4,4
88,9	080	406	12	140	80	133	9	19,6	40	12	7,8	5,0
108	108	388	16	160	100	114	11	25,2	30	12	16,3	7,8
114,3	100	390	16	168	100	111	11	25,2	30	12	16,4	7,8
127	127	490	16	182	100	154	11	25,2	30	12	12,4	9,5
133	133	488	16	188	100	150	11	25,2	30	12	12,5	9,5
139,7	125	490	16	194	100	148	11	25,2	30	12	12,6	9,6
141,3	141	488	16	196	100	146	11	25,2	30	12	12,6	9,6
159	159	588	16	214	100	187	11	25,2	30	12	10,1	11,3
168,3	150	588	16	224	100	182	11	25,2	30	12	10,3	11,4
193,7	175	636	16	250	120	193	11	25,2	30	12	11,8	14,8
219,1	200	650	16	290	120	180	11	25,2	30	16	12,4	15,0
244,5	225	692	16	312	120	190	17	25,2	30	16	11,9	16,1
273	250	692	16	342	120	175	17	25,2	30	16	12,6	16,4
323,9	300	792	16	394	150	199	17	25,2	30	16	14,2	23,5
355,6	350	842	16	426	150	208	17	25,2	30	16	13,6	25,1
377	377	842	16	448	150	197	17	25,2	30	16	14,2	25,4
406,4	400	896	20	498	150	199	23	30,8	35	20	29,6	41,4
426	426	896	20	518	150	189	23	30,8	35	20	29,6	41,8

The E dimension shown in the table is the rod spacing a standard clamp. Depending on the insulation thickness and a possible requirement for a shorter length of the hanger, the height E can be specified in the following ranges:

DN	Emin	Emax
15-40	Etab-B2	Etab+40
50-80	Etab-B2	Etab+50
100-200	Etab-B2	Etab+70
250-350	Etab-B2	Etab+80
400-500	Etab-B2	Etab+90
550-800	Etab-B2	Etab+100

MATERIAL GROUPS

MS No.	1	2	3	4	5	6	7
Tmax (°C)	350	500	580	400	500	620	350
Material	S235JR	16Mo3	10CrMo910	1.4301	1.4571	1.4948	P275NH

Upon request, the welding shear lugs can also be supplied from other materials that are more compatible with the pipe material, in terms of weldability and thermal expansion

PERMISSIBLE LOADS

The load-bearing capacity at higher temperatures and for different materials shall satisfy the following equation:  $F_{pt,M}^G = k_{t,M} \times F_p$ , where the correction factor is specified according to table 3.1.

If there is a requirement for rod spacing E different from  $E_{nom}$  listed in the table above than the permissible load needs to be worked out according to formula:  $F_p(E) = F_p \times E_{nom} / E$ .

## 44

Pipe clamp with U-bolt for horizontal pipes, connection to hanger rod via a clevis with pin. There are 3 clamp versions with different load-bearing capacity (series 1, 2 and 3) for each pipe diameter.

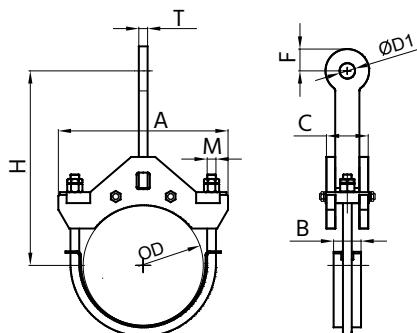

## DESIGNATION

## 44-TU MS-DNK-E

Example of designation: 44-33-225-400

TU – load-bearing capacity

DNK – pipe outer diameter code

MS – material group code

H – required H dimension (not specified when selecting the standard)

## ASSEMBLY

The Clamps is assembled from its components; all nuts are to be tightened until the clamp and the U-bolt come in full contact with the pipe. Then the U-bolt is secured with locknuts.

## SERIES 1 - DIMENSIONS AND PARAMETERS

OD	DN-K	TU	H	A	B	C	D1	T	F	M	Fp	m
mm	mm	mm	mm	mm	mm	mm	mm	mm	mm	mm	kN	kg
108	108	2	250	187	30	52	18	10	27	12	16,6	3,9
114	100	2	260	193	30	52	18	10	27	12	16,6	3,9
127	127	2	270	206	30	52	18	10	27	12	16,6	4,1
133	133	2	280	212	30	52	18	10	27	12	16,6	4,2
140	125	2	280	219	30	52	18	10	27	12	16,6	4,3
159	159	2	300	239	30	52	18	10	27	12	16,6	4,6
168	150	2	310	248	30	52	18	10	27	12	16,6	4,8
194	175	2	330	274	30	52	18	10	27	12	16,6	5,1
219	200	3	350	320	40	68	22	12	33	16	26,4	14,2
245	225	3	360	346	40	68	22	12	33	16	26,4	15,3
273	250	3	390	374	40	68	22	12	33	16	26,4	16,4
324	300	3	420	426	40	68	22	12	33	16	26,4	18,8
356	350	3	440	459	40	68	22	12	33	16	26,4	20,3
406	400	3	480	513	40	72	22	12	33	16	26,4	22,7
457	450	3	510	564	40	72	22	12	33	16	26,4	25,2
508	500	3	540	617	40	72	22	12	33	16	26,4	28,2
559	550	3	580	668	40	72	22	12	33	16	26,4	31,0
610	600	3	610	726	40	78	22	12	33	16	26,4	33,8
660	650	3	640	776	40	78	22	12	33	16	26,4	36,8
711	700	3	670	827	40	78	22	12	33	16	26,4	40,0
762	750	3	700	878	40	78	22	12	33	16	26,4	43,3
813	800	3	730	929	40	78	22	12	33	16	26,4	46,6

## SERIES 2 - DIMENSIONS AND PARAMETERS

OD	DN-K	TU	H	A	B	C	D1	T	F	M	Fp	m
mm	mm	mm	mm	mm	mm	mm	mm	mm	mm	mm	kN	kg
108	108	3	280	207	40	68	22	12	33	16	26,4	6,4
114	100	3	290	213	40	68	22	12	33	16	26,4	6,5
127	127	3	300	226	40	68	22	12	33	16	26,4	7,1
133	133	3	310	232	40	68	22	12	33	16	26,4	7,1
140	125	3	310	239	40	68	22	12	33	16	26,4	7,2
159	159	3	330	259	40	68	22	12	33	16	26,4	7,5
168	150	3	340	284	40	68	22	12	33	16	26,4	7,7
194	175	3	360	310	40	68	22	12	33	16	26,4	8,1
219	200	4	390	346	50	90	26	15	39	20	38,2	24,7
245	225	4	410	372	50	90	26	15	39	20	38,2	26,3
273	250	4	430	400	50	90	26	15	39	20	38,2	28,1
324	300	4	470	452	50	90	26	15	39	20	38,2	32,9
356	350	4	490	485	50	90	26	15	39	20	38,2	34,9
406	400	4	530	535	50	90	26	15	39	20	38,2	38,5
457	450	4	570	586	50	90	26	15	39	20	38,2	42,3
508	500	4	600	639	50	90	26	15	39	20	38,2	47,1
559	550	4	640	690	50	90	26	15	39	20	38,2	51,2
610	600	4	670	742	50	90	26	15	39	20	38,2	55,5
660	650	4	700	792	50	90	26	15	39	20	38,2	60,0
711	700	4	740	843	50	90	26	15	39	20	38,2	64,7
762	750	4	770	806	50	90	26	15	39	20	38,2	70,3
813	800	4	800	857	50	90	26	15	39	20	38,2	75,2

**SERIES 3 - DIMENSIONS AND PARAMETERS**

OD	DN-K	TU	H	A	B	C	D1	T	F	M	Fp	m
mm	mm	mm	mm	mm	mm	mm	mm	mm	mm	mm	kN	kg
108	108	4	340	233	50	90	26	15	39	20	38,2	9,7
114	100	4	350	239	50	90	26	15	39	20	38,2	9,8
127	127	4	370	252	50	90	26	15	39	20	38,2	10,4
133	133	4	370	258	50	90	26	15	39	20	38,2	10,4
140	125	4	380	265	50	90	26	15	39	20	38,2	10,5
159	159	4	400	285	50	90	26	15	39	20	38,2	11,9
168	150	4	410	294	50	90	26	15	39	20	38,2	12,0
194	175	4	440	336	50	90	26	15	39	20	38,2	13,3
219	200	5	470	372	60	112	32	20	48	24	69,4	37,1
245	225	5	500	398	60	112	32	20	48	24	69,4	39,5
273	250	5	520	426	60	112	32	20	48	24	69,4	42,2
324	300	5	570	478	60	112	32	20	48	24	69,4	47,7
356	350	5	600	511	60	112	32	20	48	24	69,4	50,6
406	400	5	640	561	60	112	32	20	48	24	69,4	55,1
457	450	5	690	612	60	112	32	20	48	24	69,4	59,2
508	500	5	730	665	60	112	32	20	48	24	69,4	65,0
559	550	5	770	716	60	112	32	20	48	24	69,4	70,1
610	600	5	810	778	60	122	32	20	48	24	69,4	74,4
660	650	5	850	828	60	122	32	20	48	24	69,4	79,7
711	700	5	880	879	60	122	32	20	48	24	69,4	85,2
762	750	5	920	930	60	122	32	20	48	24	69,4	91,0
813	800	5	960	877	60	122	32	20	48	24	69,4	96,6

The H height can be adjusted in the range of approximately +/- 50 mm.

**MATERIAL GROUPS**

MS No.	1	2	3	4	5	6	7
Tmax (°C)	350	500	580	400	500	620	350
Material	S235JR	16Mo3	10CrMo910	1.4301	1.4571	1.4948	P275NH

The table shows materials of the main U-bolt trapezes. The material of the U-bolt, base plate or other components may be different.

**PERMISSIBLE LOADS**

The load-bearing capacity at higher temperatures and for different materials shall satisfy the following equation:  $F_{pt,M}^G = k_{t,M} \times F_{p'}$  where the correction factor is specified, according to Table 3.2.

45

Riser clamp for vertical pipe hangers, connection to hanger rod is via clevis with pin. Optionally the riser clamp is secured to the pipe with either shear-lugs or trunnions. Weld-on stops (i.e. shear lugs or trunnions) are included. There are 3 clamp versions with different load-bearing capacity (series 1, 2 and 3) for each pipe diameter.

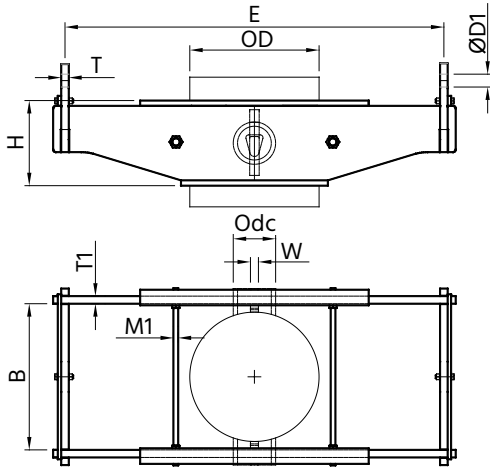

MATERIAL GROUPS

MS No.	1	2	3	4	5	6	7
Tmax (°C)	350	500	580	400	500	620	350
Material	S235JR	16Mo3	10CrMo910	1.4301	1.4571	1.4948	P275NH

Shear lugs and trunnion can also be supplied from other materials that more compatible with the pipe material, in terms of weldability and thermal expansion. The table shows the materials of the clamp's main beams. The material of the attachment plate or threaded parts may be different.

SERIES 1 - DIMENSIONS AND PARAMETERS

Do	DNK	TU	Emin	Enom	Emax	D1	T	H	B	T1	M1	W	dc	Fp	m
mm	mm	mm	mm	mm	mm	mm	mm	mm	mm	mm	mm	mm	mm	kN	kg
108	108	1	350	500	850	14	10	120	138	10	10	10	48	13,7	11
114	100	1	350	500	850	14	10	120	144	10	10	10	48	13,7	11
127	127	1	350	550	900	14	10	130	157	10	10	10	48	13,7	13
133	133	1	350	550	900	14	10	130	163	10	10	10	48	13,7	13
140	125	1	350	550	900	14	10	130	170	10	10	10	48	13,7	13
141	141	2	350	550	900	18	12	130	171	10	10	10	48	26,8	16
159	159	2	400	650	1000	18	12	150	189	10	15	10	60	26,8	21
168	150	2	400	650	1000	18	12	150	198	10	15	10	60	26,8	21
194	175	2	400	650	1000	18	12	180	224	10	15	15	76	26,8	25
219	200	2	480	700	1100	18	12	180	259	10	15	15	76	26,8	27
245	225	2	500	750	1100	18	12	180	285	10	15	15	89	26,8	29
273	250	2	550	800	1100	18	12	180	313	10	16	15	89	26,8	32
324	300	2	650	850	1200	18	12	200	364	10	16	20	114	26,8	37
356	350	3	660	950	1200	22	15	220	406	12	16	20	140	42,6	58
377	377	3	700	950	1200	22	15	220	427	12	16	20	140	42,6	58
406	400	3	820	1000	1300	22	15	220	451	12	20	25	140	42,6	61
426	426	3	840	1000	1300	22	15	220	471	12	20	25	140	42,6	62
457	450	3	850	1000	1300	22	15	220	502	12	20	25	140	42,6	62
508	500	3	900	1100	1500	22	15	260	573	15	20	25	168	42,6	83
530	530	3	950	1100	1500	22	15	260	595	15	20	25	168	42,6	84
559	550	3	980	1150	1500	22	15	260	624	15	20	25	168	42,6	88
610	600	3	1000	1200	1600	22	15	280	675	15	24	30	194	42,6	99
630	630	3	1050	1200	1600	22	15	280	695	15	24	30	194	42,6	100
660	650	3	1080	1200	1600	22	15	300	725	15	24	30	219	42,6	107
711	700	3	1200	1300	1700	22	15	300	776	15	24	30	219	42,6	116
720	720	3	1200	1200	1700	22	15	300	785	15	24	30	219	42,6	109
762	750	3	1250	1350	1700	22	15	320	827	15	24	30	245	42,6	128
813	800	3	1300	1400	1800	22	15	340	878	15	24	30	273	42,6	141
820	820	3	1320	1400	1800	22	15	340	885	15	24	30	273	42,6	141

DESIGNATION

45-TU MS-DNK-E-T

Example of designation: 45-46-400-835-P

TU – load-bearing capacity, DNK – pipe outer diameter code, MS - material group code, H – required H dimension (not specified when selecting the standard one), T – weld-on stop type: P = shear lugs, C = circular (trunnions).

ASSEMBLY

The riser clamp is assembled from its components in the tongue-groove joints; all nuts are to be hand-tightened until they fully engage and then secured by locknuts. The attachment plate is secured against sliding downwards from the grooves by means of a cover plate that is locked with a bolt. This joint is tightened with a torque in (N × m) that corresponds to the bolt dimension M in (mm).

PERMISSIBLE LOADS

The load-bearing capacity at higher temperatures and for different materials shall satisfy the following equation:  $F_{pt,M}^G = k_{t,M} \times F_p$ , where the correction factor is specified according to table 3.3.

If there is a requirement for rod spacing E different from  $E_{nom}$  listed in the table above than the permissible load needs to be worked out according to formula:  $F_p(E) = F_p \times E_{nom} / E$ .



**SERIES 2 - DIMENSIONS AND PARAMETERS**

Do	DNK	TU	Emin	Enom	Emax	D	T	H	B	T1	M1	W	dc	Fp	m
mm	mm	mm	mm	mm	mm	mm	mm	mm	mm	mm	mm	mm	mm	kN	kg
108	108	2	350	500	850	18	12	140	138	10	10	10	48	27	15
114	100	2	350	500	850	18	12	140	144	10	10	10	48	27	15
127	127	2	350	550	900	18	12	150	157	10	10	10	48	27	18
133	133	2	350	550	900	18	12	150	163	10	10	10	48	27	18
140	125	2	350	550	900	18	12	150	170	10	10	10	48	27	18
141	141	3	350	550	900	22	15	150	171	10	10	10	48	43	23
159	159	3	400	650	1000	22	15	170	189	10	15	10	60	43	30
168	150	3	400	650	1000	22	15	170	198	10	15	10	60	43	30
194	175	3	400	650	1000	22	15	200	224	10	15	15	76	43	35
219	200	3	480	700	1100	22	15	200	259	10	15	15	76	43	38
245	225	3	500	750	1100	22	15	200	285	10	15	15	89	43	41
273	250	3	550	800	1100	22	15	200	313	10	16	15	89	43	43
324	300	3	650	850	1200	22	15	220	364	10	16	20	114	43	51
356	350	4	660	950	1200	26	20	240	406	12	16	20	140	58	84
377	377	4	700	950	1200	26	20	240	427	12	16	20	140	58	84
406	400	4	820	1000	1300	26	20	240	451	12	20	25	140	58	89
426	426	4	840	1000	1300	26	20	240	471	12	20	25	140	58	89
457	450	4	850	1000	1300	26	20	240	502	12	20	25	140	58	90
508	500	4	900	1100	1500	26	20	280	573	15	20	25	168	58	117
530	530	4	950	1100	1500	26	20	280	595	15	20	25	168	58	118
559	550	4	980	1150	1500	26	20	280	624	15	20	25	168	58	123
610	600	4	1000	1200	1600	26	20	300	675	15	24	30	194	58	137
630	630	4	1050	1200	1600	26	20	300	695	15	24	30	194	58	138
660	650	4	1080	1200	1600	26	20	320	725	15	24	30	219	58	147
711	700	4	1200	1300	1700	26	20	320	776	15	24	30	219	58	159
720	720	4	1200	1200	1700	26	20	320	785	15	24	30	219	58	149
762	750	4	1250	1350	1700	26	20	340	827	15	24	30	245	58	175
813	800	4	1300	1400	1800	26	20	360	878	15	24	30	273	58	191
820	820	4	1320	1400	1800	26	20	360	885	15	24	30	273	58	192

**SERIES 3 - DIMENSIONS AND PARAMETERS**

Do	DNK	TU	Emin	Enom	Emax	D	T	H	B	T1	M1	W	dc	Fp	m
mm	mm	mm	mm	mm	mm	mm	mm	mm	mm	mm	mm	mm	mm	kN	kg
108	108	3	350	500	850	22	15	160	138	12	10	10	48	43	22
114	100	3	350	500	850	22	15	160	144	12	10	10	48	43	22
127	127	3	350	550	900	22	15	170	157	12	10	10	48	43	26
133	133	3	350	550	900	22	15	170	163	12	10	10	48	43	26
140	125	3	350	550	900	22	15	170	170	12	10	10	48	43	26
141	141	4	350	550	900	26	20	170	171	12	10	10	48	58	36
159	159	4	400	650	1000	26	20	190	189	12	15	10	60	58	46
168	150	4	400	650	1000	26	20	190	198	12	15	10	60	58	46
194	175	4	400	650	1000	26	20	230	224	12	15	15	76	58	54
219	200	4	480	700	1100	26	20	230	259	12	15	15	76	58	59
245	225	4	500	750	1100	26	20	230	285	12	15	15	89	58	63
273	250	4	550	800	1100	26	20	230	313	12	16	15	89	58	68
324	300	4	650	850	1200	26	20	250	364	12	16	20	114	58	78
356	350	5	660	950	1200	35	25	280	406	15	16	20	140	94	124
377	377	5	700	950	1200	35	25	280	427	15	16	20	140	94	125
406	400	5	820	1000	1300	35	25	280	451	15	20	25	140	94	131
426	426	5	840	1000	1300	35	25	280	471	15	20	25	140	94	132
457	450	5	850	1000	1300	35	25	280	502	15	20	25	140	94	133
508	500	5	900	1100	1500	35	25	320	573	20	20	25	168	94	171
530	530	5	950	1100	1500	35	25	320	595	20	20	25	168	94	172
559	550	5	980	1150	1500	35	25	320	624	20	20	25	168	94	180
610	600	5	1000	1200	1600	35	25	350	675	20	24	30	194	94	204
630	630	5	1050	1200	1600	35	25	350	695	20	24	30	194	94	205
660	650	5	1080	1200	1600	35	25	370	725	20	24	30	219	94	217
711	700	5	1200	1300	1700	35	25	370	776	20	24	30	219	94	235
720	720	5	1200	1200	1700	35	25	370	785	20	24	30	219	94	221
762	750	5	1250	1350	1700	35	25	390	827	20	24	30	245	94	256
813	800	5	1300	1400	1800	35	25	410	878	20	24	30	273	94	279
820	820	5	1320	1400	1800	35	25	410	885	20	24	30	273	94	279

## 46

U-bolt for attaching uninsulated pipes directly to the auxiliary structure. Use up to 300 °C. Optionally, the U-bolt can be lined with a plate or a non-metallic liner. The U-bolt can be installed as fixed (nuts are configured as per the picture below - left side) or as a guide with gap (nuts are configured as per the picture below - right side). As a standard, the U-bolt is made of carbon steel and is galvanized. For supporting stainless steel pipes, the pipe that is in contact with the U-bolt is wrapped with 0.3–0.5 mm thick PTFE liner.

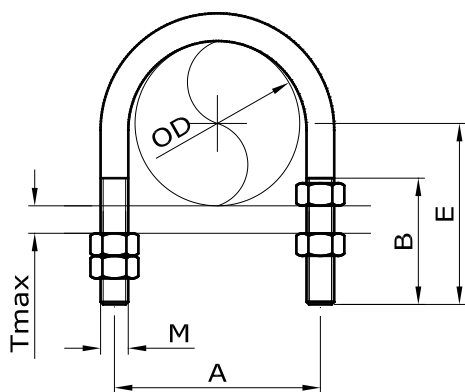

## DESIGNATION

## 46-MS-DNK

Example of designation: 46-1-80

DNK – pipe outer diameter code

MS – material group code

## ASSEMBLY

The U-bolt is assembled from its components and all nuts are tightened with a torque in (N × m) that corresponds to the bolt dimension M in (mm) and then secured with lock nuts.

## DIMENSIONS AND PARAMETERS

OD	DN-K	M	A	E	B	Tmax	Fpx	Fpy	Fpz	m
mm	mm	mm	mm	mm	mm	mm	kN	kN	kN	kg
14 – 18	10	6	26	30	27	10	0,3	1,4	3,9	0,03
20 – 24	15	6	31	38	32	15	0,3	1,4	3,9	0,04
24 – 28	20	8	38	45	40	16	0,5	2,6	6,9	0,08
32 – 35	25	8	44	50	41	18	0,5	2,6	6,9	0,09
38 – 43	32	8	53	55	42	19	0,5	2,6	6,9	0,10
48 – 50	40	10	61	65	51	22	0,8	4,0	10,8	0,17
57 – 62	50	10	73	75	55	26	0,8	4,0	10,8	0,20
73 – 78	65	12	92	90	64	29	1,3	5,9	15,2	0,37
85 – 90	80	12	105	95	63	28	1,3	5,9	15,2	0,40
108 – 116	100	16	132	120	79	32	1,9	5,9	31,3	0,83
127 – 143	125	16	161	135	81	34	1,9	5,9	31,3	0,95
159 – 170	150	16	186	145	77	30	1,9	5,9	31,3	1,04
191 – 196	175	16	216	160	79	32	1,9	5,9	31,3	1,16
215 – 223	200	20	247	190	100	42	3,0	11,0	48,4	2,13
242 – 248	225	20	270	200	97	39	3,0	11,0	48,4	2,27
273 – 280	250	20	304	220	101	43	3,0	11,0	48,4	2,50
323 – 330	300	20	354	240	96	38	3,0	11,0	48,4	2,80
350 – 361	350	20	385	260	101	43	3,0	11,0	48,4	3,01
372 – 380	377	20	402	270	101	43	3,0	11,0	48,4	3,13
400 – 411	400	24	439	290	109	43	5,0	17,1	65,2	4,91

## MATERIAL GROUPS

MS No.	1	4	7
Tmax (°C)	300	300	300
Material	S235JR	1.4301	42CrMo4

## 47

Pipe clip for attaching horizontal or vertical pipes to auxiliary structure, the clip is welded to the structure. Use up to 550 °C. Horizontal pipes can be attached from above by hanging or from below by supporting.

For supporting stainless steel pipes up to 250 °C, the pipe that is in contact with the clip is wrapped with 0.3–0.5 mm thick PTFE liner.

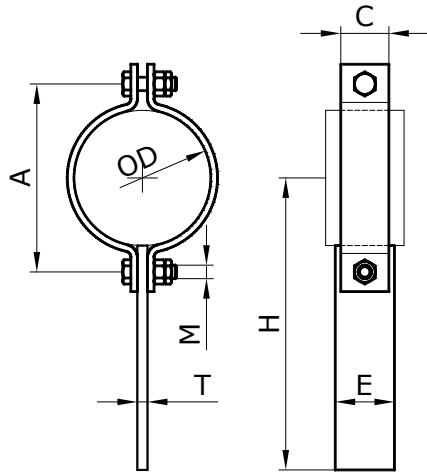

## DESIGNATION

## 47-MS-DNK

Example of designation: 47-1-025

DNK – pipe outer diameter code

MS – material group code

## DIMENSIONS AND PARAMETERS

OD	DN-K	A	C	M	H	E	T	m
mm	mm	mm	mm	mm	mm	mm	mm	kg
21,3	015	52	30	10	250	40	6	0,70
26,9	020	60	30	10	250	40	6	0,72
31,8	025	68	30	10	250	40	6	0,74
33,7	025	69	30	10	250	40	6	0,74
38	038	74	30	10	250	40	6	0,75
42,4	032	80	30	10	250	40	6	0,76
48,3	040	86	30	10	280	40	6	0,83
57	057	100	40	12	300	50	8	1,51
60,3	050	104	40	12	300	50	8	1,53

## MATERIAL GROUPS

MS	Clamp	Fixing plate
1	S235JR	S235JR
2	16Mo3	P265GH
3	10CrMo910	16Mo3
4	1.4301	S235JR
5	1.4571	S235JR

## 41-2

Weld-on lug for connection of horizontal pipes to hanger rod.

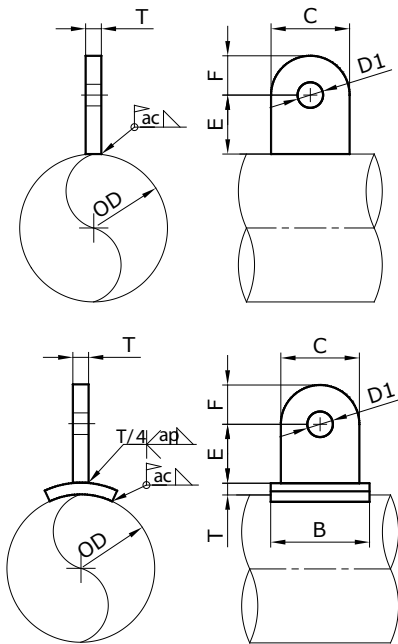

## DESIGNATION

## 41-2 MS-TU-DNK-E

Example of designation: 41-21-3-133-95

TU – load-bearing capacity

DNK – pipe outer diameter code

MS – material group code

## ASSEMBLY

The lug or reinforcing pad is welded to the pipe with a continuous fillet weld (weld size ap or ac).

## DIMENSIONS AND PARAMETERS

TU	DN	Rod	D1	C	E	F	T	B	ac	ap	Fp	m
-	mm	M	mm	mm	mm	mm	mm	mm	mm	mm	kN	kg
1	25-200	12	14	40	50	20	8	-	4	-	8,5	0,16
2	50-300	16	18	50	60	27	10	-	5	-	16,8	0,31
3	100-600	20	22	60	70	35	12	-	6	-	24,6	0,53
4	=>200	24	26	80	80	42	15	100	7	6	51,0	1,10
5	=>250	30	35	90	100	60	20	110	8	7	76,9	2,1
6	=>300	36	42	100	100	70	25	130	8	9	103	3,0
7	=>400	42	48	120	120	80	30	150	8	10	133	5,1
8	=>400	48	55	140	120	90	35	180	8	12	178	7,2

## MATERIAL GROUPS

MS No.	1	4	7
Tmax (°C)	350	350	350
Material	S235JR	1.4301	P275NH

## PERMISSIBLE LOADS

The load-bearing capacity at higher temperatures and for different materials shall satisfy the following equation:  $F_{pt,M}^G = k_{t,M} \times F_{pr}$ , where the correction factor is specified according to table 3.1.

The load-bearing capacity must be limited with respect to the permissible force of the rod assembly and the local stress on the pipe wall, that can be calculated for example according to EN 13480-3.

## 41-3

Weld-on lug for elbows.

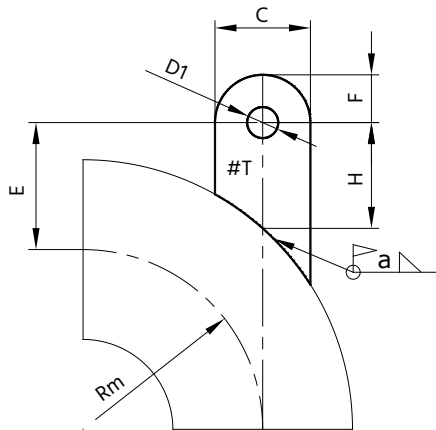

### DESIGNATION

#### 41-3 MS-TU-DNK-H

Example of designation: 41-37-2-133-120

TU – load-bearing capacity  
DNK – pipe outer diameter code  
MS – material group code

### ASSEMBLY

The lug is welded to the pipe with a continuous fillet weld (weld size a).

### DIMENSIONS AND PARAMETERS

TU	DN	Rod	D1	C	Hmin	F	T	a	Fp	m
-	mm	M	mm	mm	mm	mm	mm	mm	kN	kg
1	25-200	12	14	40	80	20	8	4	7,9	0,25
2	50-300	16	18	50	90	27	10	6	15,9	0,46
3	100-600	20	22	60	110	35	12	7	22,1	0,82
4	200-800	24	26	80	140	42	15	8	33,1	1,7
5	200-800	30	35	90	160	60	20	10	51,6	3,1

### MATERIAL GROUPS

MS No.	1	4	7
Tmax (°C)	350	350	350
Material	S235JR	1.4301	P275NH

### PERMISSIBLE LOADS

The load-bearing capacity at higher temperatures and for different materials shall satisfy the following equation:  $F_{pt,M}^G = k_{t,M} \times F_p$ , where the correction factor is specified according to table 3.1.

The load-bearing capacity must be limited with respect to the permissible force of the rod assembly and the local stress on the pipe wall, that can be calculated for example according to EN 13480-3.

## 43-2

Weld-on trunnions for connection of vertical pipes to hanger rod via a clevis and pin. The trunnions are supplied with machined weld bevels and they are welded to the pipe with a full penetration weld (i.e. a half-V weld and a fillet weld). Applicable rod dimensions are given in the table. The spacing E can be selected in the range of +/- 25% of the nominal value. The permissible load must be further checked with respect to the wall thickness of the connected pipe.

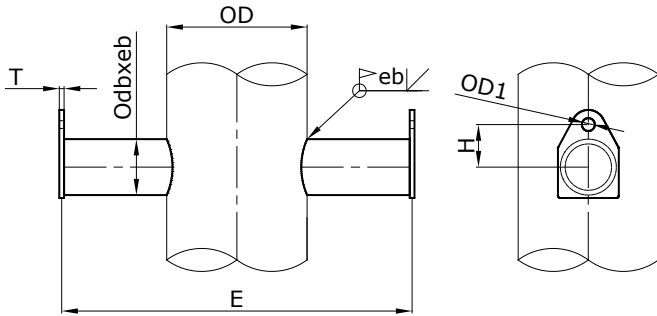

## DIMENSIONS AND PARAMETERS

DNK	OD	E	db	eb	T	D1	H	Fp	m
mm	mm	mm	mm	mm	mm	mm	mm	(kN)	(kg)
50	57	300	33,7	4,0	8	14	60	2,0	1,7
50	60	300	33,7	4,0	8	14	60	2,0	1,7
65	73	400	33,7	4,0	8	14	60	2,0	2,3
65	76	400	33,7	4,0	8	14	60	2,0	2,2
80	89	450	60,3	4,0	8	14	70	6,0	4,6
100	108	500	60,3	4,0	8	14	70	6,0	4,9
100	114	500	60,3	4,0	8	14	70	6,0	4,9
125	127	550	88,9	6,3	8	18	85	16,4	8,0
125	133	550	88,9	6,3	8	18	85	16,4	7,9
125	140	550	88,9	6,3	8	18	85	16,4	7,8
125	141	550	88,9	6,3	8	18	85	16,4	7,8
150	159	650	88,9	6,3	8	18	95	16,4	9,2
150	168	650	88,9	6,3	8	18	95	16,4	9,1
175	194	650	114,3	8,0	10	22	110	28,7	14,1
200	219	700	114,3	8,0	10	22	110	28,7	14,8
225	245	750	114,3	8,0	10	22	120	28,7	15,5
250	273	750	114,3	8,0	10	22	120	28,7	14,7
300	324	800	139,7	7,1	10	22	125	35,7	18,3
350	356	900	139,7	7,1	10	22	140	35,7	21
350	377	900	139,7	7,1	10	22	140	35,7	20
400	406	950	219,1	6,3	12	26	165	65,1	41
400	426	950	219,1	6,3	12	26	165	65,1	40
450	457	1000	219,1	6,3	12	26	165	65,1	41
500	508	1000	219,1	6,3	12	26	190	65,1	38
500	530	1050	219,1	6,3	12	26	190	65,1	39
550	559	1100	219,1	6,3	12	26	190	65,1	41
600	610	1150	219,1	6,3	15	35	240	65,1	51
600	630	1150	219,1	6,3	15	35	240	65,1	49
650	664	1200	273,0	7,1	15	35	240	89,0	65
700	711	1250	273,0	7,1	15	35	240	89,0	65
700	720	1250	273,0	7,1	15	35	240	89,0	64
750	762	1300	273,0	7,1	15	35	240	89,0	65
800	813	1350	273,0	7,1	15	35	265	89,0	65
800	820	1350	273,0	7,1	15	35	265	89,0	64

## MATERIAL GROUPS

MS No.	1	4	7
Tmax (°C)	350	350	350
Material	P235GH	1.4301	P275NH

## PERMISSIBLE LOADS

The load-bearing capacity at higher temperatures and for different materials shall satisfy the following equation:

## DESIGNATION

## 43-2 MS-TU-DNK-E

Example of designation: 43-27-4-550-980

DNK – pipe outer diameter code

TU – load-bearing capacity

MS – material group code

E – hanger rod spacing

## ASSEMBLY

The trunnions are welded to the pipe wall a full penetration weld

$F_{pt,M}^G = k_{t,M} \times F_{pr}$  where the correction factor is specified according to table 3.1.

If there is a requirement for rod spacing E different from  $E_{nom}$  listed in the table above than the permissible load needs to be worked out according to formula:  $F_p(E) = F_p \times E_{nom} / E$ .

The load-bearing capacity must be limited with respect to the permissible force of the rod assembly and the local stress on the pipe wall, that can be calculated for example according to EN 13480-3.

4

# CONNECTING RODS – THREADED CONNECTING ELEMENTS

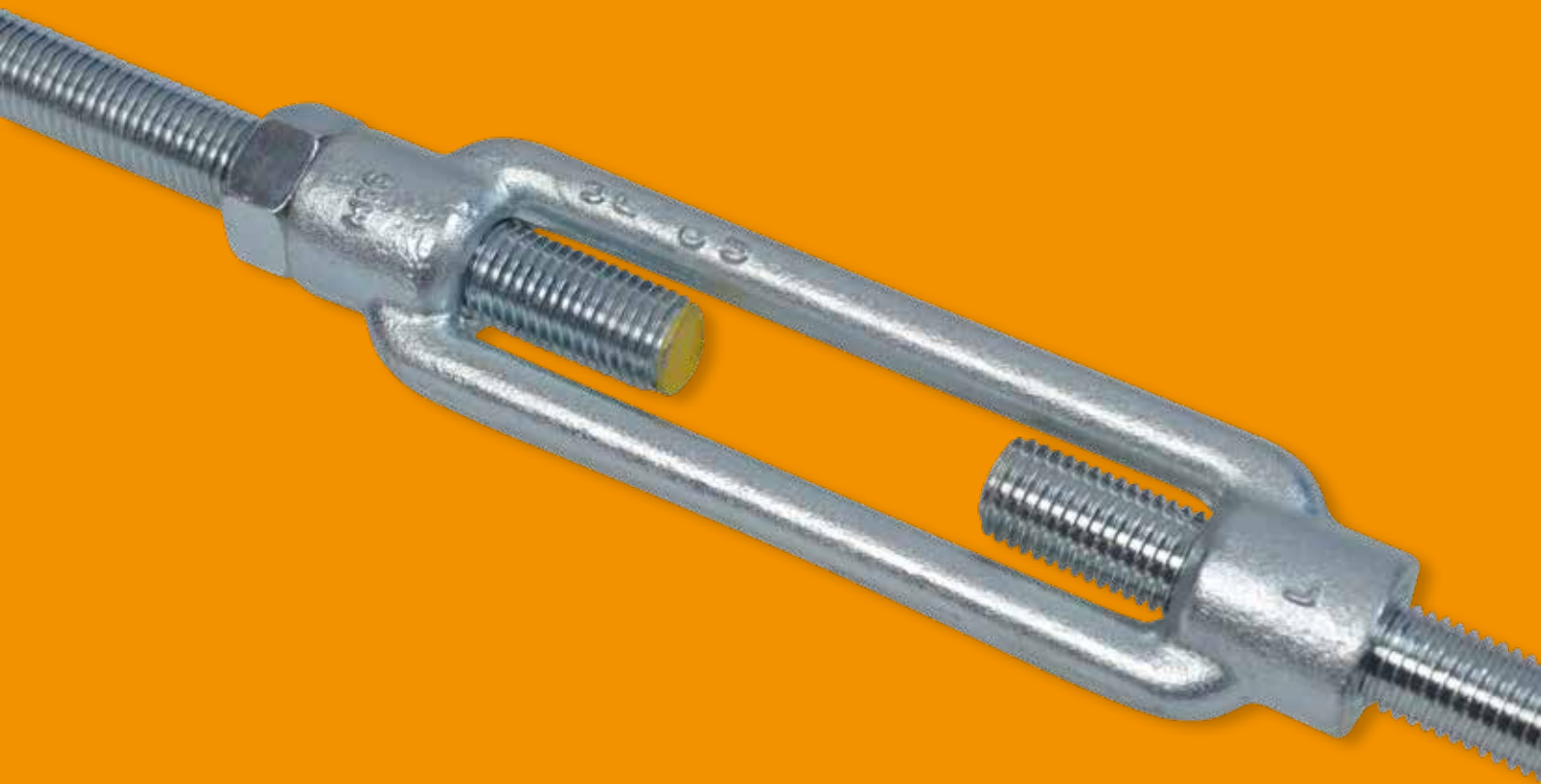

4.1. USE

Hanger rods serve the purpose of transferring forces from pipe attachment parts (pipe clamps, lugs, etc.) to structure attachment elements (eyes, clevises, pads, beam clamps, beam adapters, etc.). Permissible angular deflection of hanger rods from vertical axis is max. 4°. The hanger rod consists of a (threaded) rod, two hinge joints and rod-tensioning elements (if required). If the hanger deviation from vertical axis is less than 1° and for piping of DN < 50, only one hinge joint can be used. The hanger rod is only capable of transferring tension loads. Compression loads, if the pipe lifts off, cannot be transferred by hanger rods. Also, horizontal hanger rods cannot be used to restrain lateral pipe loads. If there is a requirement for transferring compression or lateral loads from piping, rigid struts (composed of elements of product group 8) shall be used.

Hanger rods for piping of DN ≥ 80 shall be provided with a tensioning element for adjustment or re-adjustment of the piping during operation.

Rigid hangers of vertical piping – one rod shall be able to carry the entire load of the hanger assembly unless a clamp capable of allowing its rotation in a direction perpendicular to the plane of the hanger rod pair is used.

Double-rod rigid hangers of horizontal piping – one rod shall be able to carry 2/3 of the total load on the hanger assembly.

Double-rod rigid hangers for horizontal movements that cause angular deflection of rods from vertical axis (in the plane of the rods) of more than 2.5° shall be attached to the structure at one point (see chapter 9.4.4. – configuration HR5, HR6 or HS10).

List of rod components:

Description	Type	Use, description
Threaded rod	51	Hanger rod with right-hand thread, thread is either continuous over the entire rod length or at the ends only
Right-hand/left-hand	52	Rod with one right-hand thread for a structural or pipe attachment element and left-hand thread for a turnbuckle
Turnbuckle	53	Special shaped nut fitted with a right-hand thread on one side and left-hand thread on the other side.
Eye nut	54	A drop-forged element used as a transition from a rod to a clevis with pin
Clevis with pin	55	Clevis with a female thread for connection to a rod with an inserted pin
Nut	56	Hexagonal nut for securing washers and/or securing threaded connections against loosening
Coupling nut	57	Hexagon nut for connecting two rods, equipped with an inspection hole for checking of length of engaged threads
Clamp connection plate	58	Plate with holes used for coupling of the clamps of type 42 together that are then used with one hanger rod
Clamp connection bracket	59	Two plates connected with pins used for coupling of the clamps of type 44 together that are then used with one hanger rod

Connections to pipe attachment elements:

Pipe attachment element	Connection	Element type number
Clamps	Eye nut on the rod connects to pin on the clamp. The nut eye can be of different size compared to the pin (next load group).	54
Clamps and weld-on lugs	Clevis with pin on the rod connects to hole in the weld-on lug. They must always be of the same load group.	55
Connection plate	Clevis with pin connects to hole in the connection plate of double clamps.	55

As an option, it is possible to request that the rods are fitted with two nuts above the rod tensioning nut. The aim of this is to absorb the reaction from the frictional torque when loosening or tensioning the rods.

4.2 DESIGN OF HANGER RODS

The hanger rods consist of threaded rods, pipe attachment parts and structure attachment elements.

Extension of the hanger rods must be carried out by threaded elements – welding of hanger rods is not permitted. The threaded rods must be screwed into the coupling nut symmetrically and at full depth; the check is possible through the opening in the center of the coupling nut. Also, the coupling nut must be secured on both sides with locknuts. The coupling nut is not designed and shall not be used for adjustment of the length of the rods!

Each component attached to a threaded rod must be screwed into a nut over the entire length of the nut and secured with a lock nut. Left-hand threads do not require lock nuts. The lock nuts must not be tightened with excessive torques, as local and unidentifiable tensile forces may occur in the bolt (threaded rod), which may reduce the load-bearing capacity of the rod.

The pins of the clevises must be provided with washers and secured with safety pins. Permissible angular deviation of the pin axis from horizontal axis is 5° for each type of joint.

Connections to structural attachment elements:

Structural attachment element	Connection	Element type number
Weld-on eye	Clevis with pin on the rod connects to hole in the weld-on eye. They must always be of the same load group.	55
Welding clevis	Eye nut on the rod connects to pin on the clamp. They must always be of the same load group.	54
Spherical washer	Nut attached to rod connects through hole in the spherical washer.	56
Beam clamp / beam adaptor	Clevis with pin on the rod connects to beam clamp / beam adaptor with a weld. They must always be of the same load group.	55



Length adjustment device for hanger rods:

Pipe attachment element	Connection	Element type number
Weld-on eye, Weld-on clevis, Beam clamp / Beam adaptor	Turnbuckle and right-hand / left-hand threaded rod for rigid hangers. Adjustment nut in spring canister for additional spring adjustment of +/- 15 % of the preset load	53
Spherical washer	Nut on a rod through the hole in the spherical washer.	56

### 4.3 PERMISSIBLE LOAD AND LOAD GROUPS

The permissible load  $F_p$  is designed for a tensile load in the direction of hanger rods, permissible angular deflection of hanger rods is max. 4° from vertical direction.

The load groups of the rods represent unified load-bearing capacities of rod components and unified connection dimensions that also apply to other product groups (pipe attachment elements, structural attachment elements, trapezes.) The load group is a sequence number, which is related to diameter of threaded rods and pins, compatible for all parts in the same load group. The permissible load, the “load-bearing capacity”, is specified based on the permissible load of the “weakest” link in the entire hanger rod chain. The permissible load of a particular hanger assembly may be higher than the permissible load defined in the load group. In this case, however, the partial permissible loads of all components of the must be checked.

List of dimensions and permissible loads for load groups:

Load group	Rod thread (mm)	Pin diameter (mm)	$F_p$ (kN)
0	M10	10	1,0
1	M12	12	7,6
2	M16	16	14,9
3	M20	20	23,7
4	M24	24	32,0
5	M30	33	52,3
6	M36	40	68,2
7	M42	45	93,6
8	M48	50	125
9	M56×4	60	176
H	M64×4	70	200
X	M72×4	80	328

### 4.4 SURFACE FINISH

As a standard, all rod components are supplied as galvanized in chromate A5K (J, L), according to ISO 4042. This surface treatment is suitable for atmospheric corrosion aggressiveness of class C3, according to EN ISO 12 944-2, with a service life of 10-20 years until first maintenance. If a longer life or a higher degree of atmospheric corrosion aggressiveness is required, the rod components can be supplied with the following surface finishes:

Grade	Surface finish	Specifications	Coating hickness
C3+	Galvanized	EN ISO 2081 - Fe/Zn/25/A	25 mkm
C4	Galvanized	EN ISO 2081 - Fe/Zn/25/C	25 mkm
C5	Hot dip galvanized	EN ISO 1461	85 mkm

## 51

Threaded rod with right-hand thread, continuous (version R) or end thread (version E). It is available, either, in exact required lengths or in lengths with fixed length increments of 250 mm.

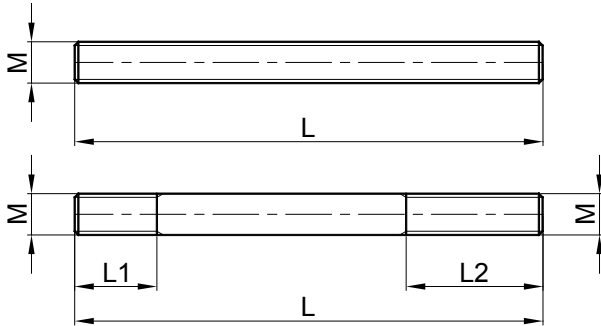

## DESIGNATION

## 51-TU-L-(MS)

Example of designation: 51-3-1500

TU – load group (thread size code), L – required rod length, MS – material group, not specified for basic material group.

## DIMENSIONS AND PARAMETERS

TU	M	L	DESIGN	L	L	L1	L2	m
-	mm	<= 1 000	<= 2 000	<= 3 000		mm	mm	kg/m
0	10					-	-	0,50
1	12					-	-	0,71
2	16					-	-	1,30
3	20			R		-	-	2,00
4	24			R		-	-	2,90
5	30			R		-	-	4,70
6	36	R				-	-	6,80
7	42					150	300	9,40
8	48					150	300	13,40
9	56×4				E	150	300	17,50
H	64×4					150	300	23,10
X	72×4			E		200	300	29,50

## MATERIAL GROUPS

MS No.	1	1	7
M	10-48	<48	all
Material	8.8	S355J0	42CrMo4

## 52

Connecting threaded rod with right-hand and left-hand end threads for rod assemblies with a turnbuckle.

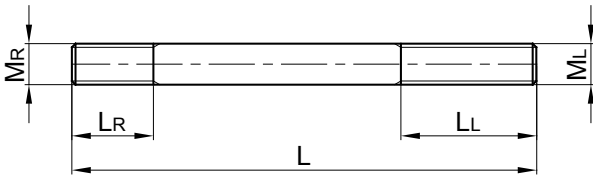

## DESIGNATION

## 52-TU- (MS)

Example of designation: 52-2-7

TU – load group (thread size code), MS – material group, not specified for basic material group.

## DIMENSIONS AND PARAMETERS

TU	M	L	LL	LR	m
-	mm	mm	mm	mm	kg
0	10	150	80	50	0,1
1	12	250	80	50	0,2
2	16	250	110	70	0,4
3	20	250	120	80	0,5
4	24	350	160	100	1,1
5	30	350	160	120	1,7
6	36	350	190	120	2,4
7	42	450	210	130	4,2
8	48	450	230	150	5,5
9	56×4	550	240	170	9,7
H	64×4	550	240	200	12,8
X	72×4	600	260	220	17,7

## MATERIAL GROUPS

MS No.	1	1	7
M	10-48	<48	all
Material	8.8	S355J0	42CrMo4

## 53

Turnbuckle with right-hand / left hand threads.

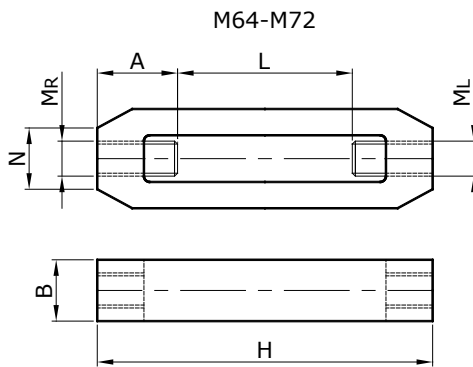
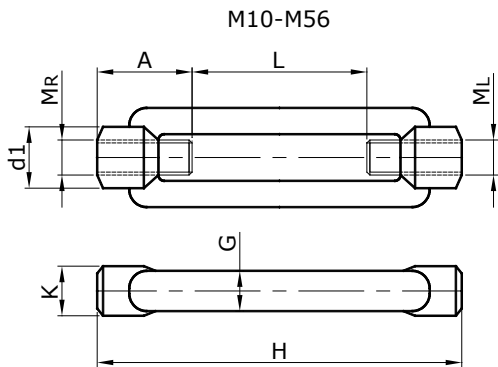

## DESIGNATION

## 52-TU- (MS)

Example of designation: 53-H

TU – load group (thread size code)

## DIMENSIONS AND PARAMETERS

TU	M	H	L	A	d1/N	K/B	G	m
-	mm	mm	mm	mm	mm	mm	mm	kg
0	10	125	40	35	18	16	9	0,1
1	12	125	45	40	21	19	11	0,2
2	16	170	60	55	27	25	14	0,4
3	20	200	70	65	34	32	17	0,7
4	24	255	95	80	39	36	20	1,2
5	30	255	85	85	45	42	23	1,8
6	36	295	95	100	55	52	28	3
7	42	330	100	115	63	60	32	4,8
8	48	355	105	125	80	77	40	7,7
9	56×4	355	105	125	80	77	40	7,7
H	64×4	380	80	70	75	120	-	24,5
X	72×4	410	80	75	80	140	-	42

## MATERIAL GROUPS

MS No.	1	1
M	10-56	64-72
Material	P245GH	S355J0

## 54

A forged eye nut for connection of thread rods with and clamp pins or structural attachment elements. The pin diameter can be selected one size greater or smaller than the size (load group) of the eye nut.

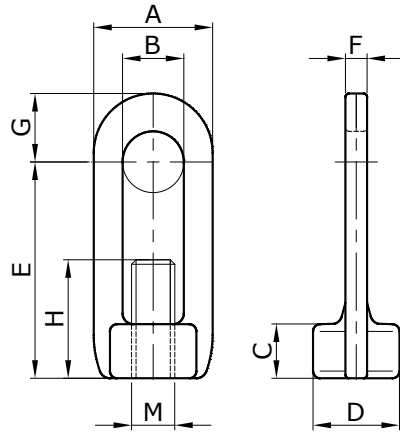

## DESIGNATION

## 54-TU

Example of designation: 54-1

TU – load group (thread size code)

## DIMENSIONS AND PARAMETERS

TU	M	A	B	E	H	G	C	D	F	m
-	mm	mm	mm	mm	mm	mm	mm	mm	mm	kg
0	10	24	13	40	15	15	11	17	5	0,1
1	12	33	17	60	20	19	15	24	6	0,1
2	16	44	25	75	30	26	20	30	10	0,2
3	20	58	28	90	35	35	27	35	10	0,4
4	24	72	35	110	40	44	30	44	15	0,8
5	30	88	42	127	45	54	37	50	17	1,2
6	36	100	47	140	55	62	45	60	20	2,0
7	42	110	52	157	60	72	52	70	25	2,9
8	48	120	62	180	70	78	60	80	30	4,7
9	56×4	140	62	200	80	80	65	80	40	8,2
H	64×4	160	72	230	90	85	70	90	40	9,1
X	72×4	200	82	250	140	110	120	100	50	26,5

## MATERIAL GROUPS

MS No.	1
Material	P245GH

## 55

Clevis with a pin for connection of a threaded rod with a pipe attachment or structural attachment element (e.g. weld-on lug, weld-on eye) into which the pin is inserted. Components attached to the pin must always be of the same load group as the clevis, considering the hole diameter and plate thickness.

## DESIGNATION

## 55-TU

Example of designation: 55-6

TU – load group (thread size code)

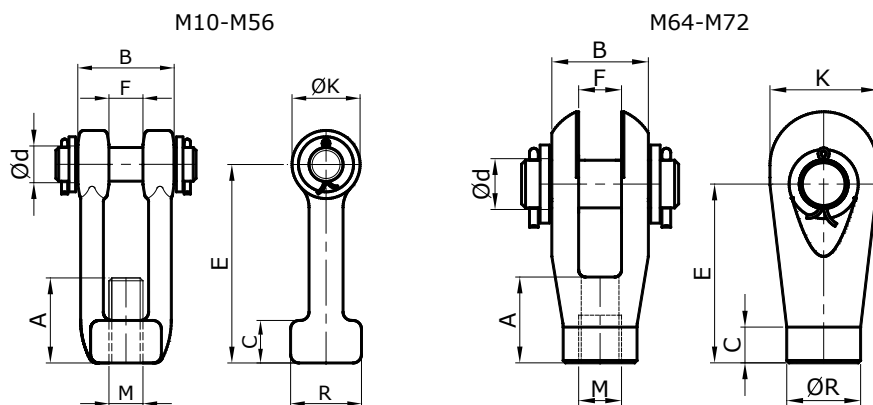

## DIMENSIONS AND PARAMETERS

TU	M	d	E	F	A	B	K	C	R	m
-	mm	mm	mm	mm	mm	mm	mm	mm	mm	kg
1	12	12	70	12	20	34	24	15	25	0,2
2	16	16	80	17	30	44	32	20	33	0,4
3	20	20	90	20	35	57	46	25	40	1,0
4	24	24	110	22	45	68	53	30	46	1,6
5	30	33	130	27	50	80	64	35	51	2,7
6	36	40	150	32	60	93	80	40	61	4,4
7	42	45	170	37	75	110	90	50	72	7,2
8	48	50	180	42	85	130	100	60	83	10,4
9	56x4	60	215	50	95	150	120	65	90	14,8
H	64x4	70	230	60	80	130	160	55	110	21,0
X	72x4	80	240	60	90	140	180	55	120	29,0

## MATERIAL GROUPS

MS No.	1	7
M	12-56	64-72
Clevis material	P245GH	S355J2
Pin material	C45E	C45E

## 56

Hexagonal nut with right-hand metric thread used for attachment of threaded rods to other parts of the hanger assembly or securing threaded rods against unscrewing. Dimensions according to ISO.

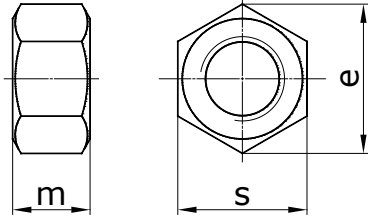

### DESIGNATION

#### 56-TU

Example of designation: 56-0

TU – load group (thread size code)

### DIMENSIONS AND PARAMETERS

TU	M	m	s	e	m
-	mm	mm	mm	mm	kg
0	10	8,4	16	17,8	0,01
1	12	10,8	18	20	0,02
2	16	14,8	24	26,8	0,03
3	20	18	30	33	0,06
4	24	21,5	36	39,6	0,10
5	30	25,6	46	50,9	0,23
6	36	31	55	60,8	0,39
7	42	34	65	71,3	0,65
8	48	38	75	82,6	0,97
9	56x4	45	85	93,6	1,43
H	64x4	51	95	104,9	2,0
X	72x4	58	105	121	2,7

### MATERIAL

Steel of grade 8, according to ISO 898-2.

## 57

Coupling nut with right-hand thread used for connection of threaded rods. The length of engaged threads must be greater than the dimension A.

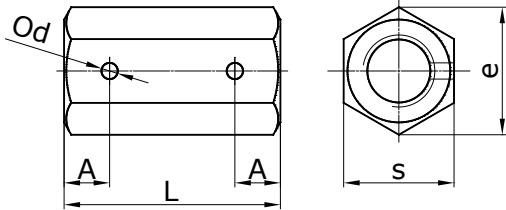

## DESIGNATION

## 57-TU

Example of designation: 57-4

TU – load group (thread size code)

## DIMENSIONS AND PARAMETERS

TU	M	L	s	e	A	d	m
-	mm	mm	mm	mm	mm	mm	kg
0	10	30	16	17,8	10	4	0,03
1	12	36	18	20	12	5	0,04
2	16	48	24	26,8	16	5	0,11
3	20	60	30	33	20	6	0,20
4	24	72	36	39,6	25	6	0,32
5	30	90	46	50,9	30	8	0,70
6	36	108	55	60,8	35	8	1,30
7	42	126	65	71,3	40	8	2,20
8	48	144	75	82,6	45	8	3,5
9	56×4	155	85	93,6	55	8	4,9
H	64×4	175	95	104,9	65	10	6,7
X	72×4	200	105	121	75	10	9,0

## MATERIAL

Steel of grade 8, according to ISO 898-2.



## 58

Clamp connection plate used for connection of 2 clamps (type 42) for single rod hangers. It connects two clamps into one rod, thus, doubling the load-bearing capacity of the pipe connecting element.

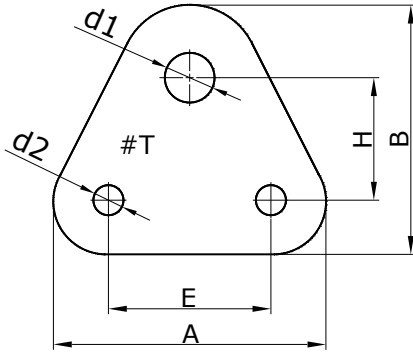

## DESIGNATION

## 58-TU1 TU2

Example of designation: 58-42

TU1 – load group of the rod and attached elements (hole d1)

TU2 – load group of the pipe clamp and attached elements (hole d2)

## DIMENSIONS AND PARAMETERS

TU1	TU2	d1	d2	A	B	E	H	T	m (kg)
2	1	18	14	115	110	70	60	10	0,5
3	1	22	14	115	116	70	60	12	0,6
3	2	22	18	148	145	90	80	12	1
4	2	26	18	148	150	90	80	15	1,3
4	3	26	22	180	175	110	100	15	1,9
5	3	35	22	180	190	110	100	20	2,7
5	4	35	26	213	215	130	120	20	3,6
6	4	45	26	213	230	130	120	25	4,8
6	5	45	35	262	255	150	130	25	6,6
7	5	50	35	262	263	150	130	30	8,1

## MATERIAL

Steel S235JR or S355J2. Galvanized.

## PERMISSIBLE LOADS

It shall be specified as the smaller of these values: twice the load-bearing capacity of the connected pipe clamp at a given design temperature, and the load-bearing capacity of the selected rod (TU1).

## 59

Clamp connection bracket 2 clamps used for single rod hangers. It connects two clamps (type 44) into one rod, thus, doubling the load-bearing capacity of the pipe connecting element. The pins are supplied with the plates.

## DESIGNATION

## 59-TU1 TU2

Example of designation: 59-65

TU1 – load group of the rod and attached elements (hole d1)

TU2 – load group of the pipe clamp and attached elements (hole d2)

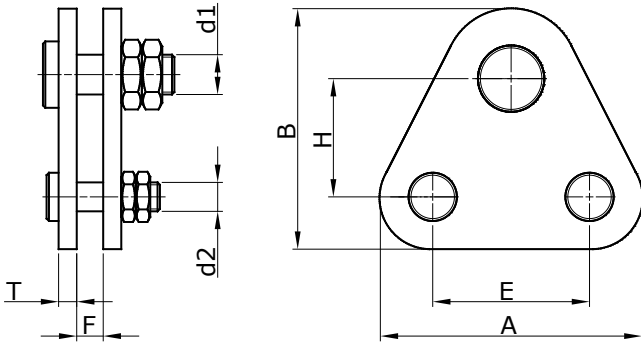

## DIMENSIONS AND PARAMETERS

TU1	TU2	d1	d2	A	B	E	H	F	T	m (kg)
5	4	33	24	200	217	130	98	19	15	7,3
6	4	40	24	200	217	130	98	22	15	7,9
6	5	40	33	225	280	160	98	22	20	14,4
7	5	45	33	225	280	160	98	27	20	15,2
7	6	45	40	261	332	180	108	27	24	26,7
8	6	50	40	261	332	180	108	32	24	27,6
8	7	50	45	290	370	200	115	32	30	40,1
9	7	60	45	290	370	200	115	37	30	41,9
9	8	60	50	340	430	240	140	37	35	63,5
H	8	70	50	340	430	240	140	42	35	65,2

## MATERIAL

Plates – steel S235JR or S355J2.

Pins – steel C45E. Galvanized.

## PERMISSIBLE LOADS

Permissible loads shall be specified as the smaller of these values: twice the load-bearing capacity of the connected pipe clamp at a given design temperature, and the load-bearing capacity of the selected rod (TU1).

5

# STRUCTURAL ATTACHMENT ELEMENTS



5.1. USE

Structural attachment elements are designed to transfer forces from hanger rod to auxiliary steel structure. Structural attachment elements for pipe hangers of DN ≥ 50 must allow rotation. The structural attachment element must always be of the same load group as the hanger rod assembly.

Depending on the method of connection, the structural attachments are:

- Welding
- Bolting
- Clamping

Structural attachments included in this product group do not include ceiling or column anchor plates for embedding in concrete.

5.2. DESIGN OF STRUCTURAL ATTACHMENT ELEMENTS

List of structural attachment elements:

Description	Type	Use
Weld-on eye	61	Connection to steels beam or plates by welding, connection to hanger rods via clevis with pin. See chapter 9.4.4. – type 1
Spherical washer	62	Connection to a pair of channels, connection to hanger rod via 2 nuts. See chapter 9.4.4. – type 2
Weld-on clevis	63	Connection to steels beam or plates by welding, connection to hanger rods via eye nut. See chapter 9.4.4. – type 3. Used for hanger assemblies with rod deviation larger than 2.5°
Beam clamps for IPN sections	64	Bolting connection to a flange of IPN section; Must be used with weld-on of type 61 or weld-on clevis of type 63
Beam clamps for IPE, HEA, HEB sections	65	Bolting connection to a flange of IPE or HEA sections; Must be used with weld-on of type 61 or weld-on clevis of type 63. See chapter 9.4.4. – type 4
Universal bracket	66	Bolting connection to attach to a beam; an eye of type 61 or clevis of type 63 shall be welded to the bracket. See chapter 9.4.4. – type 4

5.3. PERMISSIBLE LOAD AND LOAD

The permissible load  $F_p$  is set for a tensile load in the direction of hanger rods with a permissible deflection of 4° from vertical direction.

The load groups are identical to the load groups of hanger rods.

5.4. SURFACE FINISH

Welding attachments are supplied with a primer, as standard. Bolting or clamping structural attachments are available with a range of optional coatings, galvanized or hot-dip galvanized.

## 61

Weld-on eye. Connection to hanger rods via clevis with a pin.

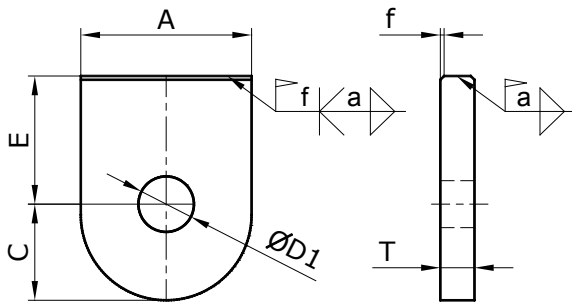

## DESIGNATION

## 61-TU MS

Example of designation: 61-17

TU – load group (thread size code)

MS – material group, not specified for basic material

## DIMENSIONS AND PARAMETERS

TU	D1	A	E	T	C	a	f	m
1	14	40	40	8	20	4	-	0,13
2	18	50	40	10	27	5	-	0,23
3	22	60	50	12	35	7	-	0,41
4	26	80	60	15	42	7	-	0,82
5	35	90	70	20	60	8	3	1,54
6	42	100	80	25	70	9	3	2,46
7	48	120	90	30	80	10	4	4,0
8	55	140	100	30	90	11	5	5,2
9	65	160	110	35	110	13	8	8,0
H	75	190	120	40	120	12	10	11,8
X	85	220	130	40	140	17	12	15,3

## MATERIAL

Group 1 - Steel S235JR

Group 7 - Steel S235NL

## 62

Spherical washer. Connection to hanger rods via a pair of nuts, allows angular deflection of  $\pm 4^\circ$ .

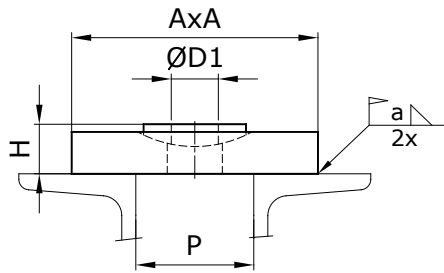

## DESIGNATION

## 62-TU

Example of designation: 61-1

TU – load group (thread size code)

## DIMENSIONS AND PARAMETERS

TU	D1	A	H	Pmax	a	m
	mm	mm	mm	mm	mm	kg
1	13	80	11,0	60	2	0,49
2	17	100	12,5	60	3	0,92
3	21	100	17,0	60	3	1,14
4	25	120	21,0	80	4	2,18
5	31	120	28,0	80	4	2,68
6	37	150	31,0	100	5	4,20
7	43	160	36,0	100	5	5,69
8	50	160	41,0	100	5	5,6
9	58	180	47,0	140	6	9,3
H	66	200	54,0	150	6	11,5
X	75	220	61,0	150	6	17,3

## MATERIAL

Steel S235JR

## 63

Weld-on clevis with pin. Connection to hanger rods via eye nut.

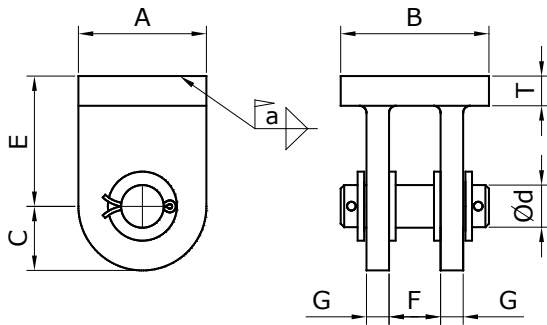

## DESIGNATION

## 63-TU-MS

Example of designation: 63-6

TU – load group (thread size code)

MS – material group, not specified for the basic material

## DIMENSIONS AND PARAMETERS

TU	d	A	B	C	E	F	G	T	m
-	mm	mm	mm	mm	mm	mm	mm	mm	kg
1	12	40	50	20	30	20	36	10	0,42
2	16	50	55	27	40	22	42	12	0,81
3	20	60	70	34	40	30	50	12	1,15
4	24	80	85	40	50	40	64	15	2,3
5	33	90	105	55	60	45	75	20	4,2
6	40	100	115	62	70	45	85	25	7,0
7	45	120	135	70	85	55	105	30	11,9
8	50	140	150	82	85	65	115	30	15,1
9	60	160	165	97	100	65	125	35	23,6
H	80	190	190	108	110	70	140	40	38,4
X	90	220	220	132	125	70	140	40	51,2

## MATERIAL

Group 1 - Steel S235JR, C45E

Group 7 - Steel S235NL, 42CrMo4

## 64

Beam clamp for IPN sections according to DIN 1025-T1. Connection to hanger rods via weld-on eye type 61 or weld-on clevis type 63.

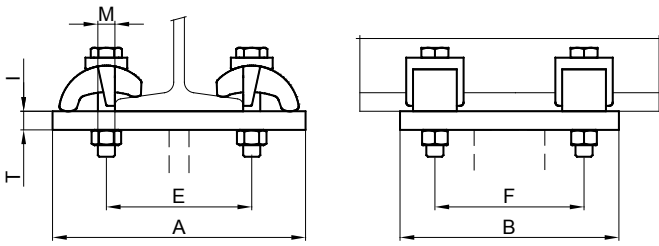

## DESIGNATION

## 64-TU-I

Example of designation: 64-3-140

TU – load group (thread size code)

I – IPN section height

## MATERIAL

Plate – steel S235JR, bolts of steel grade 8.8, adapters – cast iron EN 1563.

## DIMENSIONS AND PARAMETERS

IPN mm	TU -	No of adapters	M mm	A mm	B mm	E mm	F mm	T mm	m kg
80	0	2	10	110	80	54	-	8	0,7
100	0	2	10	115	80	62	-	8	0,7
120	0	2	10	125	80	70	-	8	0,8
140	0	2	10	135	80	78	-	8	0,8
160	0	2	10	140	80	86	-	8	0,9
80	1	2	12	120	100	56	-	10	1,2
100	1	2	12	130	100	64	-	10	1,3
120	1	2	12	135	100	72	-	10	1,3
140	1	2	12	145	100	80	-	10	1,4
160	1	2	12	155	100	88	-	10	1,5
200	1	2	12	170	100	104	-	10	1,7
100	2	4	12	130	150	64	100	15	2,9
120	2	4	12	135	150	72	100	15	3,0
140	2	4	12	145	150	80	100	15	3,2
160	2	4	12	155	150	88	100	15	3,4
180	2	4	12	160	150	96	100	15	3,5
200	2	4	12	170	150	104	100	15	3,8
120	3	4	16	155	190	76	125	20	5,8
140	3	4	16	160	190	84	125	20	6,0
160	3	4	16	170	190	92	125	20	6,3
180	3	4	16	175	190	100	125	20	6,5
200	3	4	16	185	190	108	125	20	6,9
220	3	4	16	195	190	116	125	20	7,3
240	3	4	16	200	190	124	125	20	7,5
260	3	4	16	210	190	131	125	20	7,8
280	3	4	16	215	190	137	125	20	8,0
140	4	4	20	195	220	88	150	25	10,5
160	4	4	20	205	220	96	150	25	11,1
180	4	4	20	210	220	104	150	25	11,3
200	4	4	20	220	220	112	150	25	11,9
220	4	4	20	225	220	120	150	25	12,1
240	4	4	20	235	220	128	150	25	12,7
260	4	4	20	240	220	135	150	25	13,0
280	4	4	20	250	220	141	150	25	13,5
300	4	4	20	255	220	147	150	25	13,8
160	5	4	24	220	290	100	200	25	15,7
180	5	4	24	230	290	108	200	25	16,4
200	5	4	24	240	290	116	200	25	17,1
220	5	4	24	245	290	124	200	25	17,4
240	5	4	24	255	290	132	200	25	18,1
260	5	4	24	260	290	139	200	25	18,5
280	5	4	24	265	290	145	200	25	18,9
300	5	4	24	260	270	151	200	25	17,2



## 65

Beam clamp for IPE, HEA, HEB sections. Connection to hanger rods via weld-on eye type 61 or weld-on clevis type 63.

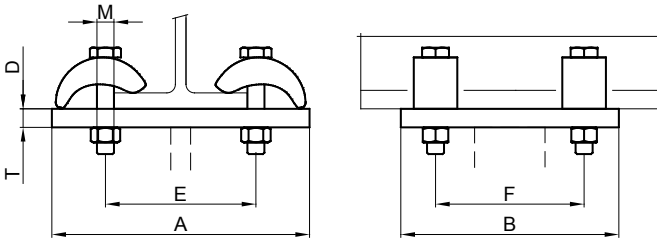

## DESIGNATION

## 65-TU X-D

Example of designation: 65-4E-140

TU – load group (thread size code)

X – section type (E for IPE, A for HEA, B for HEB)

D – section height

## MATERIAL

Plate – steel S235JR, screws of cl. 8.8, adapters – cast iron EN 1563.

## DIMENSIONS AND PARAMETERS FOR STRUCTURAL ATTACHMENTS TO IPE SECTIONS

D-IPE	TU	No of adapters	M	A	B	E	F	T	m
mm	-		mm	mm	mm	mm	mm	mm	kg
100	0	2	10	85	80	67	-	8	0,5
120	0	2	10	95	80	76	-	8	0,6
140	0	2	10	100	80	85	-	8	0,6
160	0	2	10	110	80	94	-	8	0,7
100	1	2	12	90	100	69	-	10	0,9
120	1	2	12	95	100	78	-	10	0,9
140	1	2	12	105	100	87	-	10	1,0
160	1	2	12	115	100	96	-	10	1,1
180	1	2	12	125	100	105	-	10	1,2
200	1	2	12	135	100	114	-	10	1,3
220	1	2	12	145	100	124	-	10	1,4
240	1	2	12	155	100	134	-	10	1,5
120	2	4	12	95	100	78	100	15	1,4
140	2	4	12	105	100	87	100	15	1,5
160	2	4	12	115	100	96	100	15	1,7
180	2	4	12	125	100	105	100	15	1,8
200	2	4	12	135	100	114	100	15	2,0
220	2	4	12	145	100	124	100	15	2,1
240	2	4	12	155	100	134	100	15	2,3
120	3	4	16	105	100	82	125	20	2,1
140	3	4	16	115	100	91	125	20	2,3
160	3	4	16	125	100	100	125	20	2,5
180	3	4	16	130	100	109	125	20	2,6
200	3	4	16	140	100	118	125	20	2,7
220	3	4	16	150	100	128	125	20	2,9
240	3	4	16	160	100	138	125	20	3,1
270	3	4	16	175	100	153	125	20	3,4
300	3	4	16	190	100	168	125	20	3,7
330	3	4	16	200	100	178	125	20	3,9
140	4	4	20	120	100	95	150	25	2,9
160	4	4	20	130	100	104	150	25	3,2
180	4	4	20	140	100	113	150	25	3,4
200	4	4	20	150	100	122	150	25	3,7
220	4	4	20	160	100	132	150	25	3,9
240	4	4	20	170	100	142	150	25	4,2
270	4	4	20	185	100	157	150	25	4,5
300	4	4	20	200	100	172	150	25	4,9
330	4	4	20	210	100	182	150	25	5,2
140	5	4	20	120	100	95	150	30	3,5
160	5	4	20	130	100	104	150	30	3,8
180	5	4	20	140	100	113	150	30	4,1
200	5	4	20	150	100	122	150	30	4,4
220	5	4	20	160	100	132	150	30	4,7
240	5	4	20	170	100	142	150	30	5,0
270	5	4	20	185	100	157	150	30	5,4
300	5	4	20	200	100	172	150	30	5,9
330	5	4	20	210	100	182	150	30	6,2

## DIMENSIONS AND PARAMETERS FOR STRUCTURAL ATTACHMENTS TO HEA / HEB SECTIONS

IPN mm	TU -	No of adapters	M mm	A mm	B mm	E mm	F mm	T mm	m kg
100	0	2	10	130	80	112	-	8	0,8
120	0	2	10	150	80	132	-	8	0,9
140	0	2	10	170	80	152	-	8	1,1
160	0	2	10	190	80	172	-	8	1,2
100	1	2	12	135	100	114	-	10	1,3
120	1	2	12	155	100	134	-	10	1,5
140	1	2	12	175	100	154	-	10	1,7
160	1	2	12	195	100	174	-	10	1,9
180	1	2	12	215	100	194	-	10	2,1
200	1	2	12	235	100	214	-	10	2,3
220	1	2	12	255	100	234	-	10	2,5
240	1	2	12	275	100	254	-	10	2,7
120	2	4	12	155	100	134	100	15	2,3
140	2	4	12	175	100	154	100	15	2,6
160	2	4	12	195	100	174	100	15	2,9
180	2	4	12	215	100	194	100	15	3,2
200	2	4	12	235	100	214	100	15	3,5
220	2	4	12	255	100	234	100	15	3,8
240	2	4	12	275	100	254	100	15	4,0
120	3	4	16	160	100	138	125	20	3,1
140	3	4	16	180	100	158	125	20	3,5
160	3	4	16	200	100	178	125	20	3,9
180	3	4	16	220	100	198	125	20	4,3
200	3	4	16	240	100	218	125	20	4,7
220	3	4	16	260	100	238	125	20	5,1
240	3	4	16	280	100	258	125	20	5,5
260	3	4	16	300	100	278	125	20	5,9
280	3	4	16	320	100	298	125	20	6,3
300	3	4	16	340	100	318	125	20	6,7
140	4	4	20	190	100	162	150	25	4,7
160	4	4	20	210	100	182	150	25	5,2
180	4	4	20	230	100	202	150	25	5,6
200	4	4	20	250	100	222	150	25	6,1
220	4	4	20	270	100	242	150	25	6,6
240	4	4	20	290	100	262	150	25	7,1
260	4	4	20	310	100	282	150	25	7,6
280	4	4	20	330	100	302	150	25	8,1
300	4	4	20	350	100	322	150	25	8,6
140	5	4	20	190	100	162	150	30	5,6
160	5	4	20	210	100	182	150	30	6,2
180	5	4	20	230	100	202	150	30	6,8
200	5	4	20	250	100	222	150	30	7,4
220	5	4	20	270	100	242	150	30	7,9
240	5	4	20	290	100	262	150	30	8,5
260	5	4	20	310	100	282	150	30	9,1
280	5	4	20	330	100	302	150	30	9,7
300	5	4	20	350	100	322	150	30	10,3

## 66

Bracket for IPE sections, according to DIN 1025-T2, HEA sections, according to DIN 1025-T3, HEB sections, according to DIN 1025-T2. Connection to hanger rods via weld-on eye type 61 or weld-on clevis type 63.

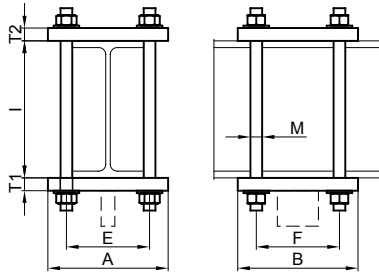

## DESIGNATION

## 66-TU X-D

Example of designation: 66-2B-160

TU – load group (thread size code)

X – section type (E for IPE, A for HEA, B for HEB)

D – section height

## MATERIAL

Plate – steel S235JR, bolts of cl. 8.8.

## DIMENSIONS AND PARAMETERS FOR STRUCTURAL ATTACHMENTS TO IPE SECTIONS

IPE mm	TU -	No of bolts	M mm	T1 mm	T2 mm	A mm	B mm	E mm	F mm	m kg
100	1	4	10	10	10	85	95	67	80	1,6
120	1	4	10	10	10	95	95	76	80	1,8
140	1	4	10	10	10	100	95	85	80	2,0
160	1	4	10	10	10	110	95	94	80	2,2
100	2	4	10	15	10	85	95	67	80	2,0
120	2	4	10	15	10	95	95	76	80	2,2
140	2	4	10	15	10	100	95	85	80	2,3
160	2	4	10	15	10	110	95	94	80	2,6
180	2	4	10	15	10	120	95	103	80	2,8
200	2	4	10	15	10	130	95	112	80	3,0
220	2	4	10	15	10	140	95	122	80	3,3
240	2	4	10	15	10	150	95	132	80	3,5
120	3	4	12	20	10	95	140	78	125	3,8
140	3	4	12	20	10	105	140	87	125	4,2
160	3	4	12	20	10	115	140	96	125	4,6
180	3	4	12	20	10	120	140	105	125	4,8
200	3	4	12	20	10	130	140	114	125	5,2
220	3	4	12	20	10	140	140	124	125	5,6
240	3	4	12	20	10	150	140	134	125	6,0
120	4	4	12	25	10	95	165	78	150	4,9
140	4	4	12	25	10	105	165	87	150	5,5
160	4	4	12	25	10	115	165	96	150	6,0
180	4	4	12	25	10	120	165	105	150	6,3
200	4	4	12	25	10	130	165	114	150	6,8
220	4	4	12	25	10	140	165	124	150	7,3
240	4	4	12	25	10	150	165	134	150	7,9
270	4	4	12	25	10	165	165	149	150	8,7
300	4	4	12	25	10	180	165	164	150	9,4
330	4	4	12	25	10	190	165	174	150	10,0
140	5	4	16	25	15	115	220	91	200	9,3
160	5	4	16	25	15	120	220	100	200	9,8
180	5	4	16	25	15	130	220	109	200	10,6
200	5	4	16	25	15	140	220	118	200	11,4
220	5	4	16	25	15	150	220	128	200	12,3
240	5	4	16	25	15	160	220	138	200	13,1
270	5	4	16	25	15	175	220	153	200	14,3
300	5	4	16	25	15	190	220	168	200	15,5
330	5	4	16	25	15	200	220	178	200	16,4
140	6	4	16	30	15	115	220	91	200	10,3
160	6	4	16	30	15	120	220	100	200	10,8
180	6	4	16	30	15	130	220	109	200	11,7
200	6	4	16	30	15	140	220	118	200	12,6
220	6	4	16	30	15	150	220	128	200	13,6
240	6	4	16	30	15	160	220	138	200	14,5
270	6	4	16	30	15	175	220	153	200	15,8
300	6	4	16	30	15	190	220	168	200	17,2
330	6	4	16	30	15	200	220	178	200	18,1

## DIMENSIONS AND PARAMETERS FOR STRUCTURAL ATTACHMENTS TO HEA / HEB SECTIONS

HE mm	TU -	No of bolts	M mm	T1 mm	T2 mm	A mm	B mm	E mm	F mm	m kg
100	1	4	10	10	10	130	95	112	80	2,3
120	1	4	10	10	10	150	95	132	80	2,7
140	1	4	10	10	10	170	95	152	80	3,0
160	1	4	10	10	10	190	95	172	80	3,4
100	2	4	10	15	10	130	95	112	80	2,8
120	2	4	10	15	10	150	95	132	80	3,2
140	2	4	10	15	10	170	95	152	80	3,6
160	2	4	10	15	10	190	95	172	80	4,1
180	2	4	10	15	10	210	95	192	80	4,5
200	2	4	10	15	10	230	95	212	80	4,9
220	2	4	10	15	10	250	95	232	80	5,3
240	2	4	10	15	10	270	95	252	80	5,7
120	3	4	12	20	10	150	140	134	125	5,6
140	3	4	12	20	10	170	140	154	125	6,3
160	3	4	12	20	10	190	140	174	125	7,0
180	3	4	12	20	10	210	140	194	125	7,8
200	3	4	12	20	10	230	140	214	125	8,5
220	3	4	12	20	10	250	140	234	125	9,2
240	3	4	12	20	10	270	140	254	125	10,0
120	4	4	12	25	10	150	165	134	150	7,4
140	4	4	12	25	10	170	165	154	150	8,4
160	4	4	12	25	10	190	165	174	150	9,4
180	4	4	12	25	10	210	165	194	150	10,4
200	4	4	12	25	10	230	165	214	150	11,4
220	4	4	12	25	10	250	165	234	150	12,3
240	4	4	12	25	10	270	165	254	150	13,3
260	4	4	12	25	10	290	165	274	150	14,3
280	4	4	12	25	10	310	165	294	150	15,3
300	4	4	12	25	10	330	165	314	150	16,2
140	5	4	16	25	15	180	220	158	200	13,8
160	5	4	16	25	15	200	220	178	200	15,3
180	5	4	16	25	15	220	220	198	200	16,8
200	5	4	16	25	15	240	220	218	200	18,3
220	5	4	16	25	15	260	220	238	200	19,9
240	5	4	16	25	15	280	220	258	200	21,4
260	5	4	16	25	15	300	220	278	200	22,9
280	5	4	16	25	15	320	220	298	200	24,4
300	5	4	16	25	15	340	220	318	200	25,9
140	6	4	16	30	15	180	220	158	200	15,4
160	6	4	16	30	15	200	220	178	200	17,1
180	6	4	16	30	15	220	220	198	200	18,7
200	6	4	16	30	15	240	220	218	200	20,4
220	6	4	16	30	15	260	220	238	200	22,1
240	6	4	16	30	15	280	220	258	200	23,8
260	6	4	16	30	15	300	220	278	200	25,5
280	6	4	16	30	15	320	220	298	200	27,1
300	6	4	16	30	15	340	220	318	200	28,8

6

# SLIDE PLATES, TRAPEZES

6.1. USE

Slide plates are used to form a good sliding surface between a support base or a guide and the supporting structure or building (floors, footings, etc.) The surfaces that slide over each other – i.e. the support base and the slide plate – shall be designed in such a way that a sufficient reserve for movement to the limit position of a min. of 25 mm is kept – this applies for movements in all operating conditions, as specified by the piping stress and flexibility analysis.

Supporting structures – posts – are used to achieve required distance between the building structure and the pipe axis. Pipe supports have limited height due to support tilting (see below) and other design aspects.

Trapezes are elements of a pipe support assemblies that allow connection of two hanger rods with a single structural attachment element or a single pipe attachment element (See chapter 9.4.4 – HR4, HR5, HR6, HS6, HS7, HS10).

Properties of sliding surfaces are described in section 1 of the catalogue, paragraphs 1.3. and 1.11.

6.2. OVERVIEW OF PLATES

Description	Type	Use
Slide plate with steel sliding surface	71-S	Sliding supports without high demands on friction coefficient, welded or bolted type
Slide plate with PTFE sliding surface	71-T	Sliding supports with base surface of M type, friction coefficient of 0.08, temperature of max. 400 °C, welded or bolted type
Slide plate with bronze-graphite sliding surface	71-B	Sliding supports with base surface of M type, friction coefficient of 0.08, temperature of over 400 °C, welded or bolted type
Slide plate with mirror sliding surface (polished stainless steel)	71-M	Sliding supports with T or B type base surface, friction coefficient of 0.08, welded or bolted type
Slide plate with guide elements	72-S	Guided sliding supports, supports without high demands on friction coefficient, welded or bolted type
Slide plate with guide elements	72-T	Guided pipe shoe, supports with base surface of M type, friction coefficient of 0.08, temperature of max. 400 °C, welded or bolted type
Slide plate with guide elements	72-B	Guided sliding supports, supports with base surface of M type, friction coefficient of 0.08, temperature over 400 °C, welded or bolted type
Slide plate with guide elements	72-M	Guided pipe shoe, supports with base surface of T or B type, friction coefficient of 0.08, welded or bolted type
Slide plate with guide elements	73-S	Guided sliding supports with lift-off restraint, supports without high demands on friction coefficient, welded or bolted type
Slide plate with guide elements	73-T	Guided sliding supports with lift-off restraint, supports with base surface of M type, friction coefficient of 0.08, temperature of max. 400 °C, welded or bolted type
Slide plate with guide elements	73-B	Guided sliding supports with lift-off restraint, supports with base surface of M type, friction coefficient of 0.08, temperature of over 400 °C, welded or bolted type
Support extension post	74	Post inserted under a support base, welded or bolted type
Trapeze	75-1	Trapeze for double-rod hangers of horizontal pipes
Connecting trapeze	75-2	Trapeze for connection of double rod hangers with a single rod connection to steel structure
Horizontal support trapeze	76	Trapeze for supporting a horizontal pipe on two spring supports
Roller	P41	Roller inserted under support base. Type P41 in the catalogue section 8.

6.3. DESIGN

a. Slide plates

According to the method of attachment to support structure, there are following types of slide plates:

- **Welding plates** – welded with continuous fillet weld along the entire perimeter of the slide plate;
- **Bolted plates** – provided with bolts, the plates have holes of required diameter and pitch for bolts that fasten the plate to steel structure;
- **Clamped plates** – provided clamps that attach the plate to steel structure beams;
- **Floor plates** – provided with anchor bolts, the plates have holes of required diameter and pitch for anchor bolts that fasten the plate to concrete floors;

According to the type of sliding surface type, the design specifics are as follows:

- **Bare** – the sliding surface is in the quality of scale-free rolled sheet, painted with a primer or coated with a slide graphite-based coating, as required;
- **Mirror** – the sliding surface is made of polished stainless steel with a surface roughness Ra of max. 0.4 µm;
- **Teflon** – the sliding surface is a round plate made of PTFE (PTFE type according to specifications), fixed to base plate with pins. The PTFE plate must be temporarily removed if the base plate is installed, so that the PTFE plate is not damaged by the welding process.

**b. Slide plates with guide elements**

Basic slide plates with guide elements are identical to the type 71 in all design versions (method of attachment to building structure, sliding surfaces). Guiding elements are of two types of design:

- L-section – two L-sections welded with continuous fillet weld along the entire perimeter of the plate;
- With lift-off restraint – two or four machined plates preventing the support base from movement and lifting off.

**c. Posts**

According to the method of attachment to building structure, there are the following types:

- Welding – welded with a continuous fillet weld along its entire perimeter;
- Bolting – provided with bolts, the plates have holes of required diameter and pitch for bolts that fasten the plate to steel structure;
- Floor – provided with anchor bolts, the plates have holes of required diameter and pitch for anchor bolts that fasten the plate to concrete floors.

Any slide or guide plate can be attached to the top plate of the post.

**6.4. SELECTION OF SLIDE AND GUIDE PLATES DIMENSIONS**

The supports, guides or other restraints have a base of given dimensions, through which the load is transferred to the surrounding structure. During operation of a piping system the support base and the slide plate move relatively over each other. In all operating situations, assembly, testing, permanent, occasional or accidental situations, the restraint must be functional, with a reserve for movement to the extreme position of a min. of 25 mm.

Fig. 6-3.1 – Slide surfaces of S type

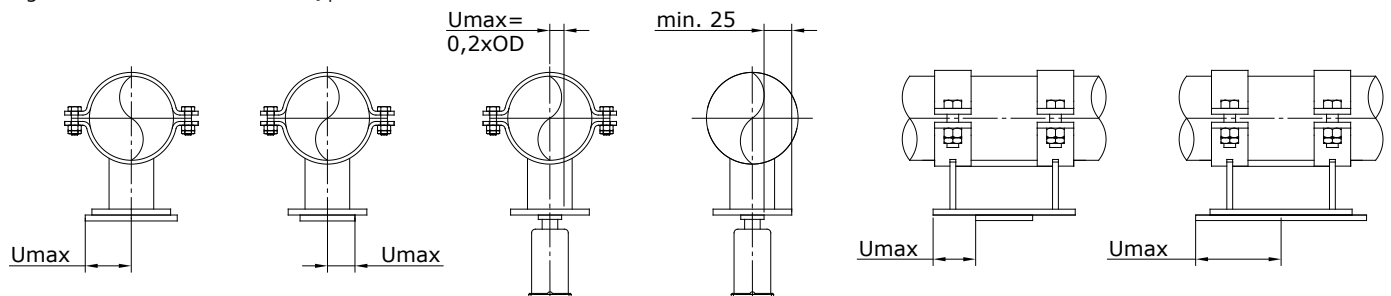
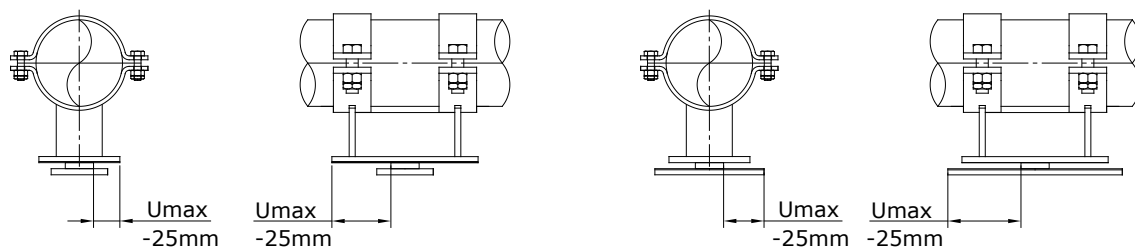

Fig. 6-3.2 – Slide surfaces of M, T and B types

**6.5. SURFACE FINISH**

As a standard, welding plates are supplied coated with a primer.

Bolted plates or plates with beam clamps, and trapezes are supplied with various coatings, galvanized or hot-dip galvanized – based on clients' requests.

**d. Trapezes**

- Hanger trapeze – consists of a pair of L-sections (for low load) or UPE sections, that are connected together with welding eyes at both ends. The welding eyes have a hole for connection of hanger rods via a clevis with pin. A pipe shoe is placed on the trapeze and secured in place against movement with spot welds.
- Support trapeze – consists of a pair channels and a U-bolt with which the pipe is attached to the trapeze. The pipe can be suspended on the U-bolt (with the trapezes on top) or laid on the trapezes. The trapeze is placed on a pair of base spring supports – for this purpose there are plates welded at both ends of the trapeze that are in contact with the spring supports.

**e. Brackets (Slide plates with beam clamps)**

Support plates with beam clamps that connect to beam flanges. A slide plate or guide plate must be welded or bolted to the brackets.

**f. Rollers**

Roller cages is provided with holes for bolts that connect the roller to supporting structure. The roller and its axle are made of stainless steel. The rollers are provided with PTFE bearings with

The dimensions of the slide plate or slide surface do not necessarily have to be larger than the area of the support base, because the increase in size of the slide plate is not always proportional to the increase in the movement reserve. In most cases, it is desirable that the support base overlaps the contact surface of slide plate – it helps reduce contamination and corrosion of the sliding surfaces.

The following recommendations apply when selecting the dimensions of the slide plate:

## 71-S

Steel slide plate for pipe shoes. Two options supplied – welding plate (without  $d_b$  holes) or bolted plate (when the value of  $d_b$  is specified). Bolts and nuts are not included. Surface finish – primer or an MoS or sintered graphite-based slide coating on top surface.

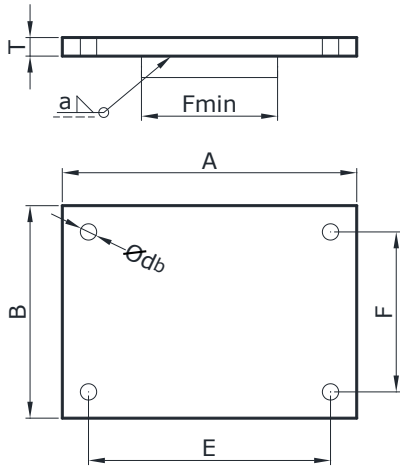

## DESIGNATION

## 71-S V-A-B-MS (db)

Example of designation: 71-S2-100-110-1 (without holes)

V – size

MS – material group

Requirement for graphite-based slide coating to specified in the order.

## DIMENSIONS AND PARAMETERS

Size	T	A	B	a	Fmin	db	E	F
V	(mm)	(mm)	(mm)	(mm)	(mm)	mm	mm	mm
1	6	80-150	80-150	3	40	9	A-3×db	B-3×db
2	8	100-200	100-200	3	60	12		
3	10	150-250	150-250	4	80	12		
4	15	160-300	160-300	5	80	18		
5	20	200-400	200-400	6	100	18		
6	25	250-500	250-500	7	120	22		
7	30	300-600	300-600	8	150	22		
8	35	300-700	300-700	10	150	22		

## MATERIAL GROUPS

Group 1 – Steel S235JR

Group 4 – Steel 1.4301



## 71-T

Steel slide plate with PTFE surface for pipe shoes. Two options supplied – welding plate (without  $d_b$  holes) or bolted plate (when the value of  $d_b$  is specified). Bolts and nuts are not included. Surface finish – primer. The PTFE plate is connected to the steel base with pins. During the process of welding of the steel base plate, the PTFE plate must be temporarily removed and re-assembled after the paint has been repaired.

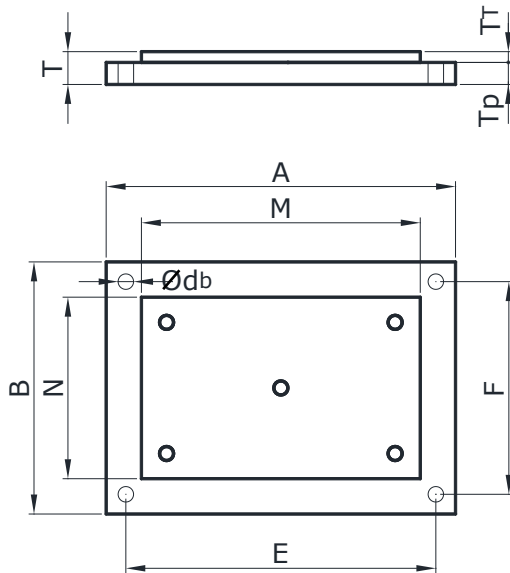

### DESIGNATION

#### 71-T V-A-B-MS (db)

Example of designation: 71-T4-160-180-418

V – size

MS – material group

### DIMENSIONS AND PARAMETERS

Size	T	TP	TT	A	B	db	M	N	E	F
V	mm	mm	mm	mm	mm	mm	mm	mm	mm	mm
1	12	6	6	90-160	90-160	9	A-40	B-40		
2	14	8	6	100-200	100-200	12	A-50	B-50		
3	16	10	6	150-250	150-250	12	A-50	B-50		
4	21	15	6	160-300	160-300	18	A-70	B-70	A-3×db	B-3×db
5	28	20	8	200-400	200-400	18	A-70	B-70		
6	33	25	8	250-500	250-500	22	A-85	B-85		
7	40	30	10	300-600	300-600	22	A-90	B-90		
8	45	35	10	300-700	300-700	22	A-90	B-90		

### MATERIAL GROUPS

Group 1 – Steel S235JR

Group 4 – Steel 1.4301

## 71-B

Steel slide plate with bronze-graphite surface pipe shoes. Two options supplied – welding plate (without  $d_b$  holes) or bolted plate (when the value of  $d_b$  is specified). Bolts and nuts are not included. Surface finish – primer. The bronze-graphite plate is connected to the steel base with pins. During the process of welding of the steel base plate, the bronze-graphite plate must be temporarily removed and re-assembled after the paint has been repaired.

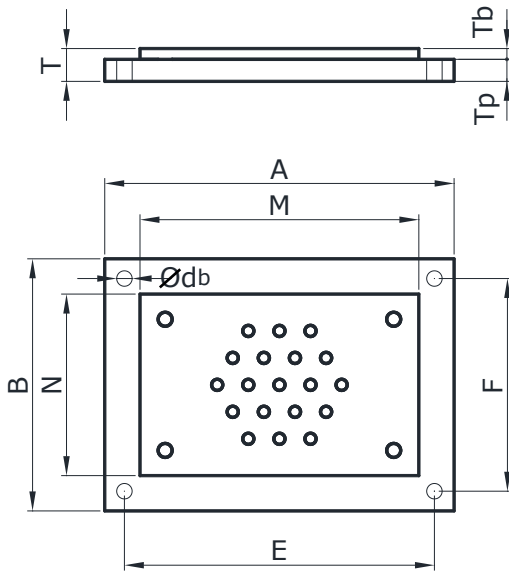

## DESIGNATION

**71-B V-A-B-MS (db)**

Example of designation: 71-B1-100-120-1

V – size

MS – material group

## DIMENSIONS AND PARAMETERS

Size	T	$T_p$	$T_b$	A	B	M	N	E	F
V	mm	mm	mm	mm	mm	mm	mm	mm	mm
1	12	6	6	90-160	90-160	A-40	B-40	A-3×db	B-3×db
2	14	8	6	100-200	100-200	A-50	B-50		
3	16	10	6	150-250	150-250	A-50	B-50		
4	23	15	8	160-300	160-300	A-70	B-70		
5	28	20	8	200-400	200-400	A-70	B-70		
6	35	25	10	250-500	250-500	A-85	B-85		
7	40	30	10	300-600	300-600	A-90	B-90		
8	47	35	12	300-700	300-700	A-90	B-90		

Size  $d_b$  identical to type 71-T.

## MATERIAL GROUPS

Group 1 – Steel S235JR

Group 4 – Steel 1.4301

## 71-M

Steel slide plate with polished stainless-steel (mirror) contact surface for sliding supports and guided sliding supports. Basic version – welding plate. Surface finish – primer, the mirror surface is with covered with a plastic foil that must be removed after the slide plate has been installed. The mirror plate is sealed around its perimeter.

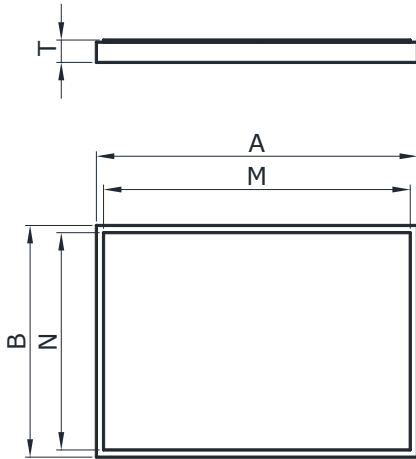

### DESIGNATION

#### 71-M V-A-B-MS

Example of designation: 71-B6-200-300-1

V – size

MS – material group

### DIMENSIONS AND PARAMETERS

Size	T	A	B	M	N
V	mm	mm	mm	mm	mm
1	10	80-150	80-150	A-5	B-5
2	12	100-200	100-200		
3	17	150-250	150-250		
4	22	160-300	160-300		
5	27	200-400	200-400		
6	32	250-500	250-500		
7	37	300-600	300-600		

### MATERIAL GROUPS

Group 1 – Steel S235JR

Group 4 – Steel 1.4301

## 72-S

Steel guiding slide plate for pipe shoes. Two options supplied – welding plate (without  $d_b$  holes) or bolted plate (when the value of  $d_b$  is specified). Bolts and nuts are not included. Surface finish – primer or an MoS or sintered graphite-based slide coating on top surface.

The dimension D is to be selected according to the width of the support base plus at least 4 mm (to allow for a 2 mm gap on each side).

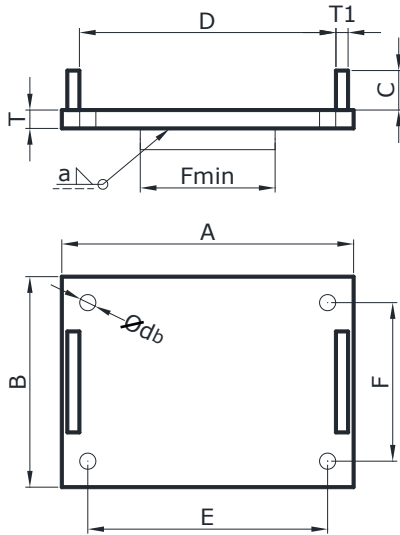

## DESIGNATION

**72-S V-D-B-MS (db)**

Example of designation: 72-S2-80-110-1 (without holes)

V – size

MS – material group

Requirement for graphite-based slide coating to specified in the order.

## DIMENSIONS AND PARAMETERS

Size	T	D	A	B	T1	C	a	Fmin	db	E	F
V	(mm)	(mm)	(mm)	(mm)	(mm)	(mm)	(mm)	(mm)	mm	mm	mm
1	6	min.	80-150	80-150	8	40	3	40	9		
2	8	5×T1	100-200	100-200	10	50	3	60	12		
3	10		150-250	150-250	12	50	4	80	12		
4	15	nom. D+3×T1	160-300	160-300	15	60	5	80	18	A-3×db	B-3×db
5	20		200-400	200-400	20	80	6	100	18		
6	25	max.	250-500	250-500	25	80	7	120	22		
7	30	A-3×T1	300-600	300-600	25	80	8	150	22		
8	35		300-700	300-700	30	100	10	150	22		

## MATERIAL GROUPS

Group 1 – Steel S235JR

Group 4 – Steel 1.4301

## 72-T

Steel guiding slide plate with PTFE surface for pipe shoes. Two options supplied – welding plate (without  $d_b$  holes) or bolted plate (when the value of  $d_b$  is specified). Bolts and nuts are not included. Surface finish – primer. The PTFE plate is connected to the steel base with pins. During the process of welding of the steel base plate, the PTFE plate must be temporarily removed and re-assembled after the paint has been repaired.

The dimension D is to be selected according to the width of the support base plus at least 4 mm (to allow for a 2 mm gap on each side).

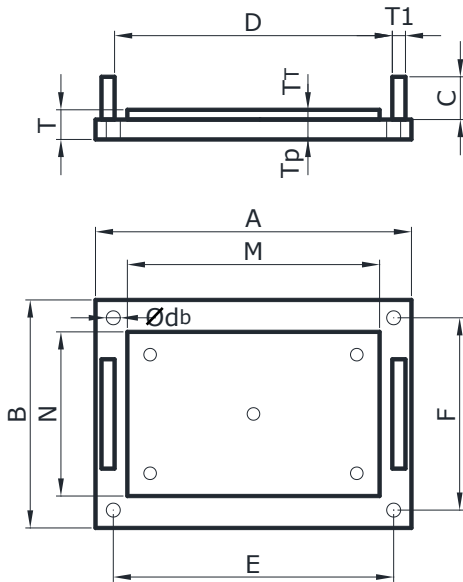

### DESIGNATION

#### 72-T V-D-B-MS (db)

Example of designation: 72-T4-130-180-418

V – size

MS – material group

### DIMENSIONS AND PARAMETERS

Size	T	D	Tp	TT	A	B	T1	C	db	M	N	E	F
V	mm	(mm)	mm	mm	mm	mm	(mm)	(mm)	mm	mm	mm	mm	mm
1	12	min.	6	6	90-160	90-160	8	40	9	D-10	B-40	A-3×db	B-3×db
2	14	5×T1	8	6	100-200	100-200	10	50	12	D-20	B-50		
3	16	nom. D+3×T1	10	6	150-250	150-250	12	50	12	D-30	B-50		
4	21		15	6	160-300	160-300	15	60	18	D-40	B-70		
5	28	20	8	200-400	200-400	20	80	18	D-40	B-70			
6	33	max.	25	8	250-500	250-500	25	80	22	D-50	B-85		
7	40	A-3×T1	30	10	300-600	300-600	25	80	22	D-50	B-90		
8	45	35	10	300-700	300-700	30	100	22	D-50	B-90			

### MATERIAL GROUPS

Group 1 – Steel S235JR

Group 4 – Steel 1.4301

## 72-B

Steel guiding slide plate with bronze-graphite surface for supports. Two options supplied – welding plate (without  $d_b$  holes) or bolted plate (when the value of  $d_b$  is specified). Bolts and nuts are not included. Surface finish – primer. The bronze-graphite plate is connected to the steel base with pins. During the process of welding of the steel base plate, the bronze-graphite plate must be temporarily removed and re-assembled after the paint has been repaired.

The dimension D is to be selected according to the width of the support base plus at least 4 mm (to allow for a 2 mm gap on each side).

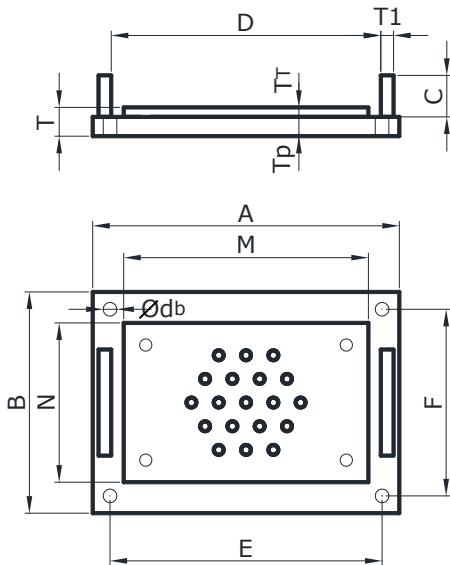

## DESIGNATION

**72-B V-D-B-MS (db)**

Example of designation: 72-B1-80-120-49

V – size

MS – material group

## DIMENSIONS AND PARAMETERS

Size	T	D	Tp	TT	A	B	T1	C	db	M	N	E	F
V	mm	(mm)	mm	mm	mm	mm	(mm)	(mm)	mm	mm	mm	mm	mm
1	12	min.	6	6	90-160	90-160	8	40	9	D-10	B-40	A-3×db	B-3×db
2	14	5×T1	8	6	100-200	100-200	10	50	12	D-20	B-50		
3	16	nom. D+3×T1	10	6	150-250	150-250	12	50	12	D-30	B-50		
4	21		15	6	160-300	160-300	15	60	18	D-40	B-70		
5	28	max. A-3×T1	20	8	200-400	200-400	20	80	18	D-40	B-70		
6	33		25	8	250-500	250-500	25	80	22	D-50	B-85		
7	40	30	10	300-600	300-600	25	80	22	D-50	B-90			
8	45	35	10	300-700	300-700	30	100	22	D-50	B-90			

## MATERIAL GROUPS

Group 1 – Steel S235JR

Group 4 – Steel 1.4301

## 72-M

Steel guiding slide plate with polished stainless-steel (mirror) contact surface for supports. Basic version – welding plate. Surface finish – primer, the mirror surface is with covered with a plastic foil that must be removed after the slide plate has been installed. The mirror plate is sealed around its perimeter. The dimension D is to be selected according to the width of the support base plus at least 4 mm (to allow for a 2 mm gap on both sides).

### DESIGNATION

#### 72-M V-D-B-MS

Example of designation: 72-B6-170-300-1

V – size

MS – material group

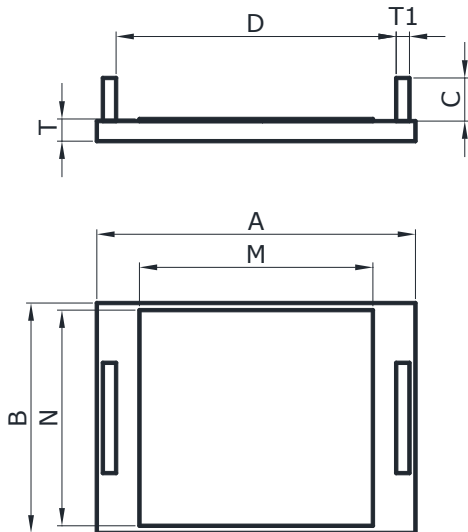

### DIMENSIONS AND PARAMETERS

Size	T	D	A	B	T1	C	M	N
V	mm	(mm)	mm	mm	(mm)	(mm)	mm	mm
1	10		80-150	80-150	8	40		
2	12		100-200	100-200	10	50		
3	17		150-250	150-250	12	50		
4	22	max. A-3×T1	160-300	160-300	15	60	A-T1-5	A-T1B-5
5	27		200-400	200-400	20	80		
6	32		250-500	250-500	25	80		
7	37		300-600	300-600	25	80		

### MATERIAL GROUPS

Group 1 – Steel S235JR

Group 4 – Steel 1.4301

## 73-S

Steel guiding slide plate with lift-off restraint for supports. Two options supplied – welding plate (without  $d_b$  holes) or bolted plate (when the value of  $d_b$  is specified). Bolts and nuts are not included. Surface finish – primer or an MoS or sintered graphite-based slide coating on top surface.

The dimension D is to be selected according to the width of the support base plus at least 4 mm (to allow for a 2 mm gap on each side).

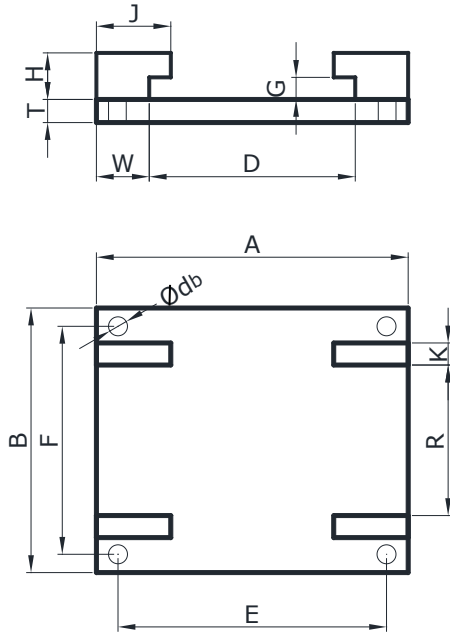

## DESIGNATION

## 73-S V-D-B-MS (db)

Example of designation: 73-S2-80-110-1 (without holes)

V – size

MS – material group

## DIMENSIONS AND PARAMETERS

Size	T	D	A	B	R	K	H	G	W	J	$d_b$	E	F
V	(mm)	(mm)	(mm)	(mm)	(mm)	(mm)	(mm)	(mm)	(mm)	(mm)	mm	mm	mm
1	6	40-100	100-160	120-160	60	8	40	8	30	36	9	A-3× $d_b$	B-3× $d_b$
2	8	50-140	130-220	160-200	80	10	45	10	40	48	12		
3	10	60-200	140-280	210-250	120	15	50	13	40	48	12		
4	15	80-250	180-350	240-300	120	15	60	17	50	60	18		
5	20	100-300	200-400	290-400	160	20	60	23	50	60	18		
6	25	120-470	240-600	360-500	200	25	70	27	60	72	22		
7	30	150-560	290-700	410-600	240	30	80	27	70	85	22		
8	35	150-660	340-800	510-700	320	40	80	27	70	85	22		

## MATERIAL GROUPS

Group 1 – Steel S235JR

Group 4 – Steel 1.4301



## 73-T

Steel guiding slide plate with lift-off restraint and with PTFE sliding surface for supports. Two options supplied – welding plate (without  $d_b$  holes) or bolted plate (when the value of  $d_b$  is specified). Bolts and nuts are not included. Surface finish – primer. The PTFE plate is connected to the steel base with pins. During the process of welding of the steel base plate, the PTFE plate must be temporarily removed and re-assembled after the paint has been repaired.

The dimension D is to be selected according to the width of the support base plus at least 4 mm (to allow for a 2 mm gap on each side).

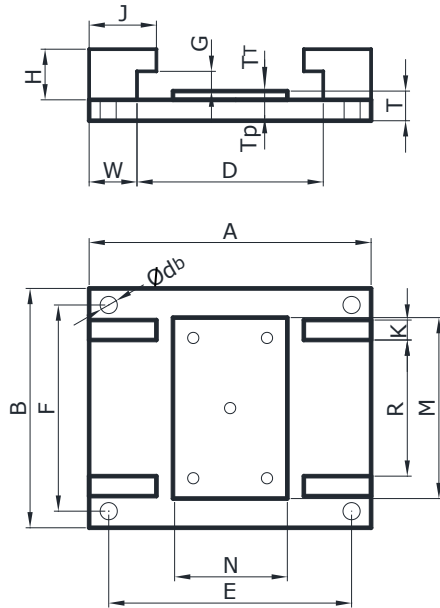

### DESIGNATION

#### 73-T V-D-B-MS (db)

Example of designation: 73-T4-130-180-418

V – size

MS – material group

### DIMENSIONS AND PARAMETERS

Size	T	D	A	B	R	K	H	G	W	J	db	M	N
V	mm	(mm)	(mm)	(mm)	(mm)	(mm)	(mm)	(mm)	(mm)	(mm)	(mm)	(mm)	(mm)
1	12	40-100	100-160	120-160	60	8	50	8	30	36	9	80	D-12
2	14	50-140	130-220	160-200	80	10	50	10	40	48	12	100	D-16
3	16	60-200	140-280	210-250	120	15	60	13	40	48	12	150	D-16
4	21	80-250	180-350	240-300	120	15	70	17	50	60	18	150	D-20
5	28	100-300	200-400	290-400	160	20	70	23	50	60	18	200	D-20
6	33	120-470	240-600	360-500	200	25	80	27	60	72	22	250	D-24
7	40	150-560	290-700	410-600	240	30	90	27	70	85	22	300	D-30
8	45	150-660	340-800	510-700	320	40	90	27	70	85	22	400	D-30

Dimensions of  $T_p$ ,  $T_r$  and E, F as in type 72-T

### MATERIAL GROUPS

Group 1 – Steel S235JR

Group 4 – Steel 1.4301

## 73-B

Steel guiding slide plate with lift-off restraint and with bronze-graphite surface for supports. Two options supplied – welding plate (without  $d_b$  holes) or bolted plate (when the value of  $d_b$  is specified). Bolts and nuts are not included. Surface finish – primer. The bronze-graphite plate is connected to the steel base with pins. During the process of welding of the steel base plate, the bronze-graphite plate must be temporarily removed and re-assembled after the paint has been repaired. The dimension D is to be selected according to the width of the support base plus at least 4 mm (to allow for a 2 mm gap both sides).

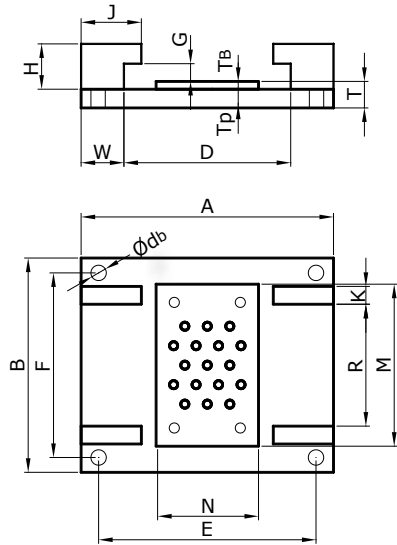

## DESIGNATION

## 73-B V-D-B-MS (db)

Example of designation: 73-B1-80-120-49

V – size

MS – material group

## DIMENSIONS AND PARAMETERS

Size	T	D	A	B	R	K	H	G	W	J	db	M	N
V	mm	(mm)	(mm)	(mm)	(mm)	(mm)	(mm)	(mm)	(mm)	(mm)	(mm)	(mm)	(mm)
1	12	40-100	100-160	120-160	60	8	50	8	30	36	9	80	D-12
2	14	50-140	130-220	160-200	80	10	50	10	40	48	12	100	D-16
3	16	60-200	140-280	210-250	120	15	60	13	40	48	12	150	D-16
4	21	80-250	180-350	240-300	120	15	70	17	50	60	18	150	D-20
5	28	100-300	200-400	290-400	160	20	70	23	50	60	18	200	D-20
6	33	120-470	240-600	360-500	200	25	80	27	60	72	22	250	D-24
7	40	150-560	290-700	410-600	240	30	90	27	70	85	22	300	D-30
8	45	150-660	340-800	510-700	320	40	90	27	70	85	22	400	D-30

Dimensions of  $T_p$ ,  $T_t$  and E, F as in type 72-T

## MATERIAL GROUPS

Group 1 – Steel S235JR

Group 4 – Steel 1.4301

## 73-A

Steel slide plate for pipe shoes with axial stops. Welding design only with standard sliding surface. Flat stops that serve as axial stops are shop welded to bottom plate of a pipe shoe and are included in delivery. Surface finish – primer.

### DESIGNATION

#### 73-A V-A-B-MS

Example of designation: 73-A2-120-140-1

V – size

MS – material group

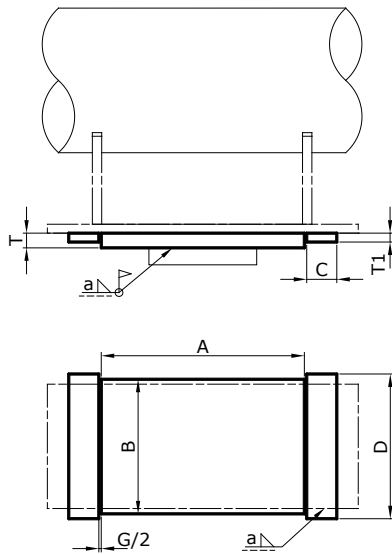

### DIMENSIONS AND PARAMETERS

Size	T	T1	A	B	C	a
V	(mm)	(mm)	(mm)	(mm)	(mm)	(mm)
1	6	8	100	100	30	3
2	8	10	120	140	40	3
3	10	12	140	200	40	4
4	20	15	160	240	50	4
5	25	20	180	300	50	5
6	30	25	200	400	50	5
7	35	30	250	450	60	6
8	40	35	300	500	60	6

## 74

Tubular post for supports with required height greater than the height standard pipe shoes. Two options supplied – welding post (without db holes) or bolting plate (when the value of db is specified). Bolts and nuts are not included. Surface finish – primer. The post can be used directly for sliding supports, or a slide plate of types 71-73 can be mounted on its top surface.

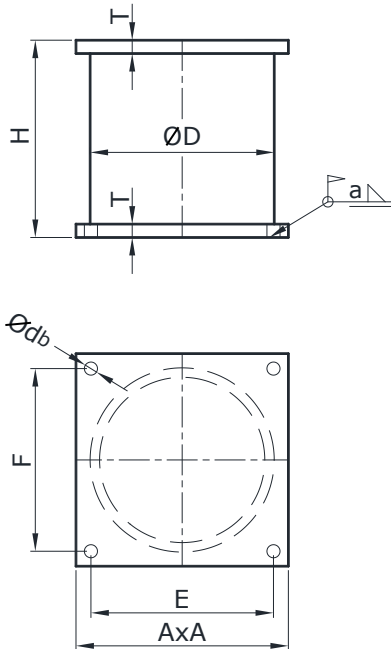

## DESIGNATION

## 74-V-H-(db)

Example of designation: 74-3-118

V – size

db – diameter of anchor bolt hole

## DIMENSIONS AND PARAMETERS

Size	A	D	T	db	E=F	Hmin	Hmax	a
V	mm	mm	mm	mm	mm	mm	mm	mm
1	80	60,3	6	9	53	62	400	3
2	100	88,9	6	9	73	62	500	3
3	140	114,3	8	12	104	66	600	4
4	160	139,7	10	12	124	76	700	4
5	200	168,3	12	14	158	80	800	4
6	250	219,1	12	14	208	80	900	5
7	300	273	15	18	246	100	1000	5
8	350	323,9	15	18	296	100	1000	5

## MATERIAL GROUPS

Group 1 – Steel S235JR

## 75-1

Trapeze for rods of hangers supporting horizontal piping, connection to clevis with pin of type 56. The pipe is connected to the trapeze via pipe shoes listed in section 1 of this catalogue. Short versions of pipe shoes (with 1 clamp) can be used as – e.g. 21.3, 21.4, 23.2. The pipe shoe shall be located preferably in the center of the span and secured with an assembly weld.

For load groups L, 0, 1:

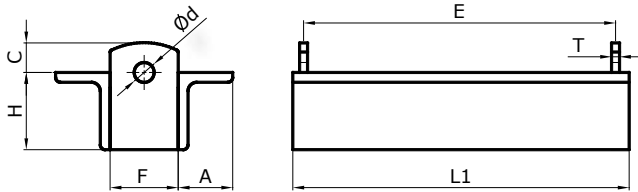

### DESIGNATION

#### 75-1 TU-H-E

Example of designation: 75-14-120-1058

TU – load group, H – section height, E – rod spacing

For load group over 2:

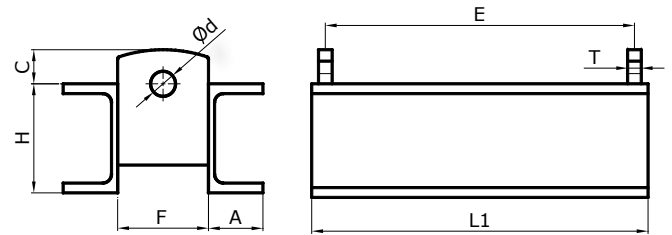

### DIMENSIONS AND PARAMETERS

TU	d	Hmin*	Hmax*	T	F	C	L1=E+
Size	mm	mm	mm	mm	mm	mm	mm
1	14	60	80	8	40	20	16
2	18	75	100	10	50	25	20
3	22	80	120	12	60	35	24
4	26	100	140	15	80	40	30
5	35	120	160	20	90	45	40
6	42	140	200	25	100	55	50
7	48	160	270	30	120	65	60
8	55	200	300	30	140	75	60

\* Multiple sections can be selected for one load group, depending on E dimension.

### OPTIONAL TRAPEZE SECTIONS AND APPROXIMATE WEIGHT M1 FOR E SPACING = 1 000 mm:

Section	L60×40×6	L75×50×7	UPE80	UPE100	UPE120	UPE140	UPE160	UPE200	UPE240	UPE270	UPE300
H (mm)	60	75	80	100	120	140	160	200	240	270	300
A (mm)	40	50	40	46	52	58	64	76	90	95	100
m1 (kg)	10	14	17	21	26	31	37	49	65	76	95

### DIMENSIONS AND PARAMETERS

H mm	Fp (kN) for rod spacing E (mm)																						
	500	600	700	800	900	1000	1100	1200	1300	1400	1500	1600	1700	1800	1900	2000	2100	2200	2300	2400	2500		
60	10,7	8,9	7,6	6,7	5,9	5,3	4,9	4,5															
75	19,7	16,4	14,0	12,3	10,9	9,8	8,9	8,2	7,6	7,0	6,6												
80	42,4	42,4	41,5	36,3	32,3	29,0	26,4	24,2	22,3	20,4	17,8												
100	55,9	55,9	55,9	55,9	50,0	45,0	40,9	37,5	34,6	32,2	30,0	28,1	26,5										
120	75,1	75,1	75,1	75,1	73,5	66,1	60,1	55,1	50,9	47,2	44,1	41,3	38,9	36,7									
140	86,3	86,3	86,3	86,3	86,3	86,3	85,0	77,9	71,9	66,8	62,3	58,5	55,0	52,0	49,2	46,8							
160	104,7	104,7	104,7	104,7	104,7	104,7	104,7	103,9	95,9	89,1	83,2	78,0	73,4	69,3	65,6	62,4	59,4	56,7	54,2	52,0	49,9		
200	141,3	141,3	141,3	141,3	141,3	141,3	141,3	141,3	141,3	141,3	141,3	141,3	139,6	130,8	123,2	116,3	110,2	104,7	99,7	95,2	91,0	87,2	83,7
240	196,7	196,7	196,7	196,7	196,7	196,7	196,7	196,7	196,7	196,7	196,7	196,7	196,7	196,7	193,7	182,9	173,3	164,6	156,8	149,7	143,2	137,2	131,7
270	232,3	232,3	232,3	232,3	232,3	232,3	232,3	232,3	232,3	232,3	232,3	232,3	232,3	232,3	232,3	225,0	213,7	203,5	194,3	185,8	178,1	171,0	
300	317,1	317,1	317,1	317,1	317,1	317,1	317,1	317,1	317,1	317,1	317,1	317,1	317,1	317,1	317,1	317,1	303,9	289,4	276,2	264,2	253,2	243,1	

The permissible loads are specified for trapeze design temperature of 150 °C.

Maximum permissible load of the trapeze can only be considered of maximum 120 % of permissible load of a single hanger rod!

Permissible load for hydrotest conditions is  $F_{p,occ} = 1.43 \times F_p$ .

The pipe shoes that are placed on the trapeze must be secured against movement with weld. Usually, it is sufficient to use 4 tack-welds 3 to 5 mm long on the bottom side of the pipe shoe. Longer welds may cause damage to the surface finish under the support – i.e. in places where no repair coat can be applied

## 75-2

The trapeze is used for connection of two hanger rods to a single rod in hanger assemblies of horizontal or vertical piping. Connection to the pair of rods via clevises with pin and weld-on eyes at the edges of the trapeze. Connection to central rod via spherical washer and nuts. The trapeze can be used as shown in the picture or can be turned upside down.

For load group L, 0, 1:

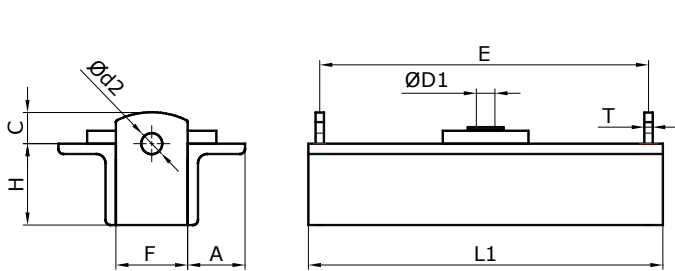

## DESIGNATION

## 75-2 TU-H-E

Example of designation: 75-25-160-1550

TU – load-bearing capacity, H – section height, E – rod spacing

For load groups 2 and higher:

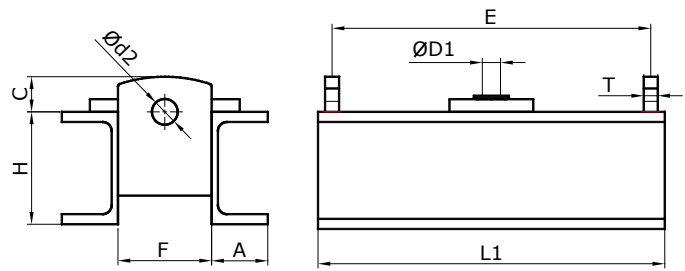

## DIMENSIONS AND PARAMETERS

TU	d2	D1	Hmin*	Hmax*	T	F	C	L1=E+
Size	mm	mm	mm	mm	mm	mm	mm	mm
1	14	17	60	80	8	40	20	16
2	18	21	75	100	10	50	25	20
3	22	25	80	120	12	60	35	24
4	26	31	100	140	15	80	40	30
5	35	37	120	160	20	90	45	40
6	42	43	140	200	25	100	55	50
7	48	50	160	270	30	120	65	60
8	55	58	200	300	30	140	75	60

\* Multiple sections can be selected for one load group, depending on E dimension.

## OPTIONAL TRAPEZE SECTIONS AND APPROXIMATE WEIGHT M1 FOR E SPACING = 1 000 mm:

Section	L60×40×6	L75×50×7	UPE80	UPE100	UPE120	UPE140	UPE160	UPE200	UPE240	UPE270	UPE300
H (mm)	60	75	80	100	120	140	160	200	240	270	300
A (mm)	40	50	40	46	52	58	64	76	90	95	100
m1 (kg)	10	14	17	21	26	31	37	49	65	76	95

The permissible loads for the trapeze section, depending on the height of the H section and E spacing, are the same as for type 75-1.

## 76

Trapeze made of a pair of channels – used for supporting horizontal piping on 2 base spring supports. Load plate, located on top of the spring support, is placed under a slide plate of AxF dimensions, the slide plate is welded to the trapeze. The trapezes can only be used for piping with operating temperatures up to 250 °C (limited by heat transfer). For horizontal movements above 10 mm it is necessary to use low-friction pads. A large enough reserve of movement must be considered (for the connection of slide plate – load plate on the spring support). The trapeze can also be used for angulating supports.

## DESIGNATION

## 76-MS-DNK-E

Example of designation: 76-3-765-5

DNK – pipe diameter code

E – spacing of hanger rods

MS – material group

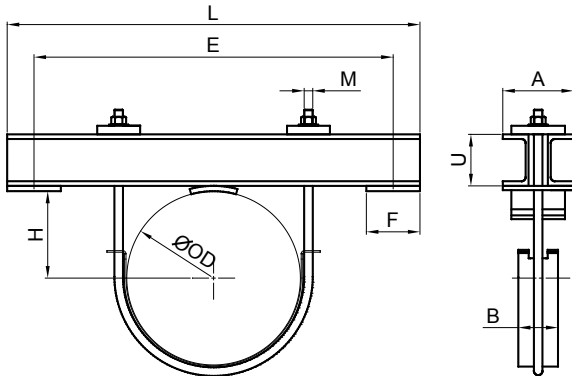

## DIMENSIONS AND PARAMETERS

DN	OD	U	M	H	A	B	E	L	F	m1
mm	mm	mm	mm	mm	mm	mm	mm	mm	mm	kg/1m
100	108	80	12	60	100	90	500-1500	E+100	80	18
100	114,3	80	12	64	100	90	500-1500	E+100	80	19
125	127	80	12	70	100	90	500-1500	E+100	80	19
125	133	80	12	73	100	90	500-1500	E+100	80	19
125	139,7	80	12	76	100	90	500-1500	E+100	80	19
150	159	100	16	88	120	110	500-1700	E+120	100	24
150	168,3	100	16	93	120	110	500-1700	E+120	100	24
175	193,7	100	16	105	120	110	500-1700	E+120	100	24
200	219,1	120	20	118	140	130	550-1800	E+140	120	30
225	244,5	120	20	131	140	130	500-1800	E+140	120	31
250	273	120	20	145	140	130	550-1800	E+140	120	31
300	323,9	120	20	170	140	130	600-1800	E+140	120	31
350	355,6	160	24	188	170	160	700-2500	E+160	140	45
400	406,4	160	24	214	170	160	750-2500	E+160	140	45
450	457	160	24	239	170	160	800-2500	E+160	140	46
500	508	200	30	264	200	190	850-2500	E+170	150	59
550	559	200	30	290	200	190	900-2500	E+170	150	59
600	610	200	30	315	200	190	1000-2500	E+170	150	59

## PERMITTED LOADS FOR TRAPEZE SECTION DEPENDING ON SECTION HEIGHT AT SPACING E:

U	Fp (kN) for E spacing (mm)																				
	500	600	700	800	900	1000	1100	1200	1300	1400	1500	1600	1700	1800	1900	2000	2100	2200	2300	2400	2500
80	23,8	23,8	23,3	20,4	18,1	16,3	14,8	13,6	12,5	11,6	10,9										
100	31,4	31,4	31,4	31,4	28,1	25,3	23,0	21,1	19,4	18,1	16,9	15,8	14,9								
120	42,2	42,2	42,2	42,2	41,2	37,1	33,7	30,9	28,5	26,5	24,7	23,2	21,8	20,6							
140	48,5	48,5	48,5	48,5	48,5	48,5	47,7	43,8	40,4	37,5	35,0	32,8	30,9	29,2	27,6	26,3	25,0	23,9	22,8	21,9	21,0
160	58,8	58,8	58,8	58,8	58,8	58,8	58,8	58,4	53,9	50,0	46,7	43,8	41,2	38,9	36,9	35,0	33,3	31,8	30,4	29,2	28,0
200	79,3	79,3	79,3	79,3	79,3	79,3	79,3	79,3	79,3	79,3	78,4	73,5	69,1	65,3	61,9	58,8	56,0	53,4	51,1	49,0	47,0

Note: The permissible loads are designed for piping operating temperature of 2 350 °C.

Permissible load for hydrotest conditions is  $F_{p,occ} = 1.43 \times F_p$

7

# RIGID STRUTS



## 7.1. USE

Support assemblies with rigid struts are designed to limit pipe movement by restraining tension/compression forces in the axis of the strut. In terms of restraint type, strut assemblies can be used for:

- Restraining the pipe movement in one axis, perpendicular to the pipe;
- Restraining the pipe movement in direction of pipe axis;
- Restraining the pipe movement in two axes, perpendicular to the pipe.

The struts are used to restrain movement caused by static loads (e.g. restrained thermal expansion), as well as dynamic (e.g. from fluid flow) and occasional loads (e.g. wind, seismic event).

Unlike guides, described in section 2 of this catalogue, the gaps in the rigid strut assemblies are very small. Therefore, for piping with higher operating temperatures, it is preferable to use rigid struts as opposed to guides that require a larger gap. However, the rigid struts may slightly deflect the pipe axis during the transition from cold to hot condition.

For restraints where a gap is required, a type 82 strut can be used. This type of strut allows free movement within the specified gap range and becomes a rigid restraint when the limit position is reached.

The strut bars can be installed both in horizontal and vertical directions.

The components of the rigid strut assembly are designed for angular deflection of 6°. If there is a risk of dynamic loads or for applications with dynamic loads, it is recommended to secure the pipe against slipping and rotation at the pipe clamp with a weld-on shear lug.

The total gap (free play) in the rigid strut assemblies is 0.5 mm for nominal connection pin diameters  $d$  of less than 30 mm, for higher values of  $d$ , the gap is less than 1.5 % of the pin diameter.

The strut assemblies are designed for both static and cyclic loading, for load amplitudes from  $\Delta F = 1.5 \times F_p$  at 25 cycles up to  $\Delta F = 0.1 \times F_p$  at 330 000 cycles, where  $F_p$  is the permissible load in (kN) specified in the component data sheet.

## 7.2. OVERVIEW OF TYPES

Overview of the rigid strut components:

Description	Type	Use
Rigid strut of fixed length	81	Rigid strut with ball bushing joint for transfer of tension / compression loads, no gap allowed
Rigid strut with gap	82	Rigid strut with ball bushing joint for transfer of tension / compression loads, with a gap
Pipe clamp for cyclic load	83	Pipe clamp for DN ≤ 80 for connection to strut
Dynamic pipe clamp	84	Pipe clamp for connection to strut, used for restraining forces perpendicular to the direction of pipe axis
Pipe clamp for double strut assembly	85	Pipe clamp for connection of two struts, used for restraining forces in the direction of pipe axis
Clevis with pin for cyclic or dynamic	86	Weld-on clevis with pin for connection of rigid strut to steel structure

## 7.3. DESIGN

### Rigid struts

– consist of a tubular rod, ball bushing joints at both ends and a tensioning mechanism. The struts of types 81 and 82 are adjustable in length by means of right-hand/left-hand threads in the range of +/-50–100 mm. The strut of type 81 has fixed length, while the type 82 strut allows movement with a specified gap, and it becomes rigid only after the limit position has been reached. The stiffness of the rigid struts in compression is set by the maximum allowable deflection of 1 mm for each 1 m of the length  $L$  of the strut. The sliding surfaces of the ball bushing joints are of steel-steel type and allow continuous operation at temperatures up to 150 °C and short-term operation up to 250 °C. The ball bushing joints are maintenance-free.

### Clamps

– consist of multiple elements that are assembled during the assembly of the piping system. The clamp connects to the strut by means of a pin that is part of clamp. The clamps type 84 consist of a U-bolt lined with a steel plate that holds the pipe to the clamp body and is connected to strut with a pin. The type 85 clamp has a box section design – it consists of cross beams, that sit on weld-on trunnions attached to the pipe, and lateral beams, to which clevises of type 86 are welded.

The diameter of the clamp structural attachment is selected, according to the diameter of used weld-on trunnions.

The clamps can be used for all types of pipes, even for those calibrated to the inner diameter. On request, special clamps for inclined pipes can be designed. The clamps can be used for pipes with tolerance of outer diameter up to 2.5 %. A requirement for clamps for pipes with a tolerance of the pipe outer diameter greater than 1% must be specified in the order.

### Clamps type 83

– consist of two half-clamps made of strip steel, which are connected by bolts. The clamp is equipped with a pin that attaches to the eye nut of the strut. The pin diameter in the clamp corresponds to the diameter of the pin in the strut.

Clamps of this type are elements of low rigidity – this should be considered in the piping stress and flexibility analysis.

The clamps of type 84 are designed for pipes calibrated to outer diameter. The clamps can only be used for pipes with an outer diameter tolerance up to 1%.

### Clevis

It consists of a carbon steel body and a pin secured with safety pins. The clevis is welded to the supporting structure with a continuous fillet weld. The welds of elements loaded with dynamic loads should be subjected to non-destructive testing.

## 7.4. DESIGN LOAD AND DESIGN TEMPERATURE

The **design load** of all components of the rigid strut assembly shall be specified for the category of permanent load according to the following equation:  $F_d T = 1.0 \times F_a T$ , where the index T expresses the temperature combinations of the analyzed operating conditions that are acting simultaneously with the load.  $F_a$  is the restraint load value from the piping stress and flexibility analysis.

The loads acting on dynamic pipe clamps used at temperatures above 400 °C (time-dependent load bearing capacity) must be categorized as follows:

- Permanent loads of category G – loads with duration of more than 10,000 hours;
- Occasional loads – loads with duration of less than 10 000 hours.

**Correction factors  $k_{t, M}$  shall be used for assessment of permissible loads for dynamic pipe clamps use at temperatures above 150 °C and those manufactured from different materials. The factors have different values for**

**load categories G (permanent) and different for category Q (occasional).**

Note:

The load-bearing capacity of rigid struts of types 81 and 82 in compression is at least twice value of critical buckling force.

**Design temperature  $T_d$**

is equal to the maximum allowable temperature of the piping without any margin. The design temperature  $T_{dc}$  must be specified by the customer, according to the procedure:

- For temperatures below the creep range, (<450 °C) -  $T_{dc}$  is equal to the maximum allowable piping temperature,
- For temperatures in creep range (approximately above 450 °C) -  $T_{dc}$  is equal to the average piping operating temperature of the most frequent cycle, if the difference between the maximum and minimum cycle temperatures is not greater than 10 °C, or
- The maximum allowable piping temperature without any margin (reserve), specified by relevant standards.

## 7.5. PERMISSIBLE LOAD AND LOAD GROUPS

The permissible load  $F_p$  is calculated for a tensile load in the direction of the strut and with respect to the permissible angular deflection of the strut of 6°.

The load groups of struts represent a uniform permissible load for all components of the rigid strut assembly and set uniform dimensions of connecting pins. The load group is a serial number to which the diameter of the strut structural attachment pin is assigned.

List of dimensions and permissible loads for load groups:

Load-bearing capacity	Pin diameter (mm)	$F_{p,G}$
(kN)	10	6
1	12	10
2	17	20
3	20	30
4	25	50
5	30	70
6	40	120
7	50	200
8	70	400

For occasional loads of category Q, the conversion shall be as follows:  $F_{p,Q} = 1,2 \times F_{p,G}$ .

The values of comparative loads  $F_p$  stated in the tables of the data sheets, are set for basic design temperature of 80 °C, and for structural attachments of the material group (MS) 1 and load category G. The load-bearing capacity at higher temperatures and for other materials shall be evaluated using the following formulas:  $F_{p,T,M} = k_{t,M} \times F_p$ , where the correction factor is set according to the tables provided for each type of pipe clamp.

## 7.6. SURFACE FINISH

The struts are available with galvanized (standard) or hot-dip galvanized (on request) ball bushing joints and other parts with a topcoat for corrosive environment C4.

Dynamic pipe clamps made of carbon steel (material groups 1, 2 and 7) are supplied, as a standard, with a primer or topcoat. A requirement for galvanized or hot-dip galvanized clamps made of material group 1 for temperatures up to 200 °C shall be specified in the order. Dynamic clamps made of alloy steel (material group 3) are supplied with a primer. Dynamic clamps made of stainless steel (material groups 4, 5, 6) are supplied without a surface finish.

Weld-on eyes and pins are supplied, as a standard, with a primer or topcoat.

## 81

Rigid strut of fixed length with ball bushing joint for tension and compression loads. Ball bushing joints allow angular deflection of the struts up to 6°. It can be used for static or dynamic (cyclic) load. Connection only to elements listed in this chapter of the catalogue (i.e. type 83 through to 86). Length adjustment during installation (no load) up to  $\pm 25$  to 50 mm from nominal length  $L_{nom}$ .

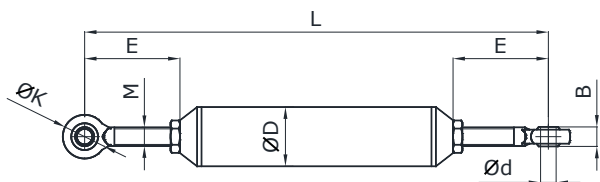

## DESIGNATION

## 81-TU-L

Example of designation: 81-3-1240

TU – load group (connecting pin diameter code)

L – required strut length

## DIMENSIONS AND PARAMETERS

TU	d	M	B	K	D	Lmin	Lmax	Enom	m/1m
-	mm	mm	mm	mm	mm	mm	mm	mm	kg
0	10	16×2	9	39	38,0	395	1500	90	3,6
0	10	16×2	9	39	48,3	395	2300	90	5,6
1	12	16×2	10	39	48,3	395	1800	90	5,6
1	12	16×2	10	39	60,3	395	2500	90	7,1
2	17	20×2	14	55	60,3	420	1800	75	7,7
2	17	20×2	14	55	76,1	420	2800	75	12,0
3	20	24×2	16	63	76,1	465	2300	80	12,6
3	20	24×2	16	63	88,9	465	3200	80	17,9
4	25	30×2	20	78	88,9	565	2500	140	19,2
4	25	30×2	20	78	114,3	565	3500	140	26
5	30	36×3	22	90	88,9	635	2200	110	21
5	30	36×3	22	90	114,3	635	3200	110	28
6	40	48×3	28	120	114,3	740	2500	115	32
6	40	48×3	28	120	139,7	740	3400	115	40
7	50	56×3	35	150	139,7	880	2500	235	46
7	50	56×3	35	150	168,3	880	3700	235	60
8	70	80×4	40	215	168,3	1190	2600	325	85
8	70	80×4	40	215	219,1	1190	3700	325	116

TU – load group, the permissible load see table on in chapter 7.5.

## MATERIAL DESIGN

Carbon steel.

## ASSEMBLY

Before installation, the length of the assembly (clamp-strut-clevis with pin) must be checked in order to make sure that the threads of the ball bushing joints are as close to the center position as possible. Appropriate pins (only the ones supplied can be used) are inserted into both ball bushing joints, and the position of joints is set on the pin center by means of washers. The pins must be secured with retaining rings. The strut is tensioned by turning the strut body by hand (one of the ball bushing joints has right-hand thread, the other has left-hand thread.) The threads of the ball bushing joints are secured against rotation with lock nuts.

## 82

Rigid strut with gap equipped with ball bushing joint for tension and compression loads. Ball bushing joints allow angular deflection of the struts up to 6°. It can be used for static or dynamic (cyclic) load. Connection only to elements listed in this chapter of the catalogue (i.e. type 83 through to 86). Length adjustment during installation (no load) up to  $\pm 25$  to 50 mm from nominal length  $L_{nom}$ .

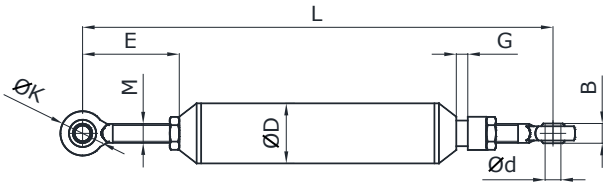

## DESIGNATION

## 82-TU-L-G

Example of designation: 82-4-1732-13

TU – load group (connecting pin diameter code)

L – required strut connection spacing

G – required gap

## DIMENSIONS AND PARAMETERS

TU	d	M	B	K	D	Lmin	Lmax	Enom	m/1m
-	mm	mm	mm	mm	mm	mm	mm	mm	kg
0	10	16x2	9	39	38,0	395	1500	90	3,6
0	10	16x2	9	39	48,3	395	2300	90	5,6
1	12	16x2	10	39	48,3	395	1800	90	5,6
1	12	16x2	10	39	60,3	395	2500	90	7,1
2	17	20x2	14	55	60,3	420	1800	75	7,8
2	17	20x2	14	55	76,1	420	2800	75	12,0
3	20	24x2	16	63	76,1	465	2300	80	12,7
3	20	24x2	16	63	88,9	465	3200	80	18,0
4	25	30x2	20	78	88,9	565	2500	140	19,5
4	25	30x2	20	78	114,3	565	3500	140	26
5	30	36x3	22	90	88,9	635	2200	110	21
5	30	36x3	22	90	114,3	635	3200	110	28
6	40	48x3	28	120	114,3	740	2500	115	33
6	40	48x3	28	120	139,7	740	3400	115	41
7	50	56x3	35	150	139,7	880	2500	235	47
7	50	56x3	35	150	168,3	880	3700	235	61
8	70	80x4	40	215	168,3	1190	2600	325	90
8	70	80x4	40	215	219,1	1190	3700	325	121

TU – load group, the permissible load see table on in chapter 7.5.

## MATERIAL DESIGN

Carbon steel.

## ASSEMBLY

Before installation, the length of the assembly (clamp-strut-clevis with pin) must be checked in order to make sure that the threads of the ball bushing joints are as close to the center position as possible. Appropriate pins (only the ones supplied can be used) are inserted into both ball bushing joints, and the position of joints is set on the pin center by means of washers. The pins must be secured with retaining rings. The strut is tensioned by turning the strut body by hand (one of the ball bushing joints has right-hand thread, the other has left-hand thread.)

The tensioning shall be carried out according to the drawing, so that the strut is its desired cold position and the gap for the desired movement in the hot condition is defined. The threads of the ball bushing joints are secured against rotation with lock nuts.

## 83

Dynamic pipe clamp for rigid strut assemblies, connection to strut via ball bushing joint. The clamp is secured against rotation by a steel strip welded to the pipe – the middle bolt of the clamp passes through the welded strip.

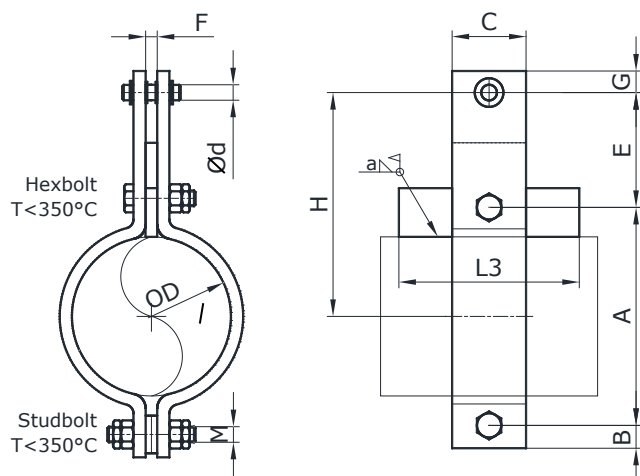

## DESIGNATION

**83-DNK- MS – (H)**

Example of designation: 83-065-2

DNK – pipe outer diameter code

MS – material group code

H – required H dimension (not specified when selecting the standard)

## ALLOWABLE LOADS

The load-bearing capacity for higher temperatures and for materials different to group 1 material shall be obtained using the following formulas:  $F_{pt,M}^G = k_{t,M} \times F_p$  a  $F_{pt,M}^Q = 1,2 \times k_{t,M} \times F_p$ , where the correction factor is listed in the table below.

## DIMENSIONS AND PARAMETERS

OD mm	DNK mm	d mm	H mm	C mm	F mm	E mm	M mm	A mm	B mm	G mm	L3 mm	Fp kN	m kg
21,3	015	10	76	50	10	50	10	52	15	17	125	8,1	0,8
26,9	020	10	80	50	10	50	10	60	15	17	125	8,1	0,9
31,8	025	10	94	50	10	60	10	68	15	17	125	8,1	0,9
33,7	025	10	94	50	10	60	10	68	15	17	125	8,1	0,9
38	038	10	106	50	10	70	10	72	15	17	125	8,1	1,0
42,4	032	10	108	50	10	70	10	76	15	17	125	8,1	1,0
48,3	040	10	122	50	10	80	10	84	15	17	125	8,1	1,1
57	057	12	130	60	12	80	12	100	18	20	150	11,5	2,1
60,3	050	12	131	60	12	80	12	102	18	20	150	11,5	2,1
73	073	12	148	60	12	90	12	116	18	20	150	11,5	2,3
76,1	065	12	150	60	12	90	12	120	18	20	150	11,5	2,3
88,9	080	12	167	60	12	100	12	134	18	20	150	11,5	2,6

## MATERIAL GROUPS

MS No.	1	2	3	4	5	6	7
Tmax (°C)	350	500	580	400	500	620	350
Material	S235JR	16Mo3	10CrMo910	1.4301	1.4571	1.4948	P275NH

## PERMISSIBLE LOAD CORRECTION FACTORS AT THE TEMPERATURE KT,M (-) FOR TYPE 83:

MS / T (°C)	80	100	150	200	250	300	350	400	450	480	490	500	510	520	530	540	550	560	570	580	600	
1	1,00	0,95	0,90	0,85	0,76	0,62	0,55															
2	1,22	1,21	1,14	1,07	0,97	0,89	0,84	0,80	0,73	0,67	0,66	0,58	0,46	0,38	0,30	0,25						
3									0,97	0,90	0,83	0,75	0,66	0,58	0,50	0,43	0,37	0,32	0,27	0,24		
4	0,98	0,87	0,79	0,72	0,66	0,62	0,60	0,59	0,57													
5	1,01	0,95	0,90	0,85	0,81	0,76	0,75	0,74	0,71	0,70	0,69	0,68	0,68									
6										0,58	0,56	0,55	0,54	0,54	0,53	0,52	0,52	0,52	0,51	0,50	0,50	
7	1,12	1,12	1,06	0,97	0,89	0,82	0,78	0,76	0,71													

## ASSEMBLY

Before installation of the clamp, the welding stop (flat bar) is to be welded on to the pipe wall with a continuous fillet weld of  $a = 3$  mm. The clamp is assembled by bolting the half-clamps together – the bolts are to be hand-tightened until the half-clamps come in full contact with the pipe. Then the bolts are to be tightened by further by  $180^\circ$  using a wrench. Spacer rings must be inserted on bolts in between the half-clamps.

## 84

Dynamic pipe clamp for rigid strut assemblies, connection to strut via ball bushing joint. The clamp is secured against rotation by a steel strip welded to the pipe – the middle bolt of the clamp passes through the welded strip. The nuts of the U-bolt are to be hand-tightened (no pre-stressing is allowed).

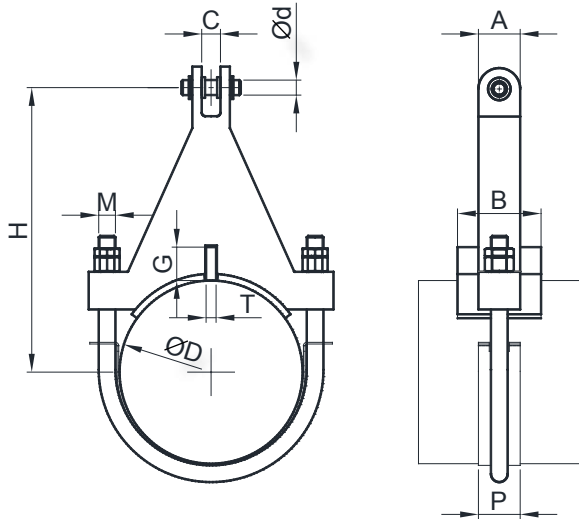

## DESIGNATION

**84-TU MS-DNK-H**

Example of designation: 84-13-250-420

TU – load group

MS – material group code

H – required H dimension (not specified when selecting the standard)

## DIMENSIONS AND PARAMETERS DEPENDING ON TUBE DIAMETER

DN-K	OD mm	Hmin* mm	Hmax mm	B mm	G mm	T mm
108	108	174	294	150	30	10
100	114,3	177	290	150	30	10
127	127	184	304	150	30	10
133	133	187	307	150	30	10
125	139,7	190	303	150	30	10
159	159	240	360	150	40	10
150	168,3	244	355	150	40	10
175	193,7	257	368	150	40	10
200	219,1	310	400	180	50	15
225	244,5	322	413	180	50	15
250	273	337	445	180	50	15
300	323,9	362	490	180	50	15
350	355,6	378	515	180	50	15
400	406,4	443	600	200	60	20
450	457	469	625	200	60	20
500	508	494	650	200	60	20
550	559	520	675	200	60	20
600	610	545	700	200	60	20

## DIMENSIONS AND PARAMETERS DEPENDING ON THE LOAD GROUP

d mm	M mm	A mm	C mm	P mm
12	12	35	19	30
17	16	50	29	50
20	20	60	30	60
25	24	80	38	70
30	30	90	48	76
40	36	120	66	100

## COMBINATIONS OF DIMENSIONS

DNK	d=12	d=17	d=20	d=25	d=30	d=40
100	x	x	x			
125	x	x	x			
150	x	x	x	x		
175	x	x	x	x	x	
200	x	x	x	x	x	x
225	x	x	x	x	x	x
250	x	x	x	x	x	x
300	x	x	x	x	x	x
350	x	x	x	x	x	x
400		x	x	x	x	x
450		x	x	x	x	x
500		x	x	x	x	x
550		x	x	x	x	x
600		x	x	x	x	x

## MATERIAL GROUPS

MS No.	1	2	3	4	5	6	7
Tmax (°C)	350	500	580	400	620	350	350
Material	S235JR	16Mo3	10CrMo910	1.4301	1.4948	P275NH	P275NH

## PERMISSIBLE LOAD CORRECTION FACTORS AT THE TEMPERATURE KT,M (-) FOR TYPE 84:

MS / T (°C)	80	100	150	200	250	300	350	400	450	480	490	500	510	520	530	540	550	560	570	580	600	
1	1	0,96	0,96	0,96	0,96	0,94	0,91															
2						0,78	0,77	0,76	0,74	0,73	0,78	0,77	0,76	0,74								
3									0,78	0,78	0,77	0,77	0,58	0,78	0,78	0,77	0,77	0,58				
4	0,75	0,75	0,75	0,75	0,74	0,73	0,71	0,69														
5									0,42	0,41	0,41	0,41	0,40	0,40	0,39	0,39	0,39	0,39	0,38	0,37		
6	0,75	0,74	0,68	0,63	0,58	0,53	0,49															0,50
7	1,12	1,12	1,06	0,97	0,89	0,82	0,78	0,76	0,71													

## ALLOWABLE LOADS

The load-bearing capacity for higher temperatures and for materials different to group 1 material shall be obtained using the following formulas:  $F_{pt,M}^G = k_{t,M} \times F_p$  a  $F_{pt,M}^Q = 1,2 \times k_{t,M} \times F_p$ , where the correction factor is listed in the table above.

## ASSEMBLY

Before installation of the clamp, the welding stop (flat bar) is to be welded on to the pipe wall with a continuous filler weld of a = 3 mm.

The clamp is to be assembled from individual components; all nuts are to be hand-tightened, until the clamp comes in full contact with the pipe, and then secured with lock nuts.

## 85

Dynamic pipe clamps for cyclic loads. Used for assemblies with 2 struts. Connection to strut via ball bushing joints. The pipe is secured against rotation in the clamps by means 2 trunnions, which are welded on to the pipe.

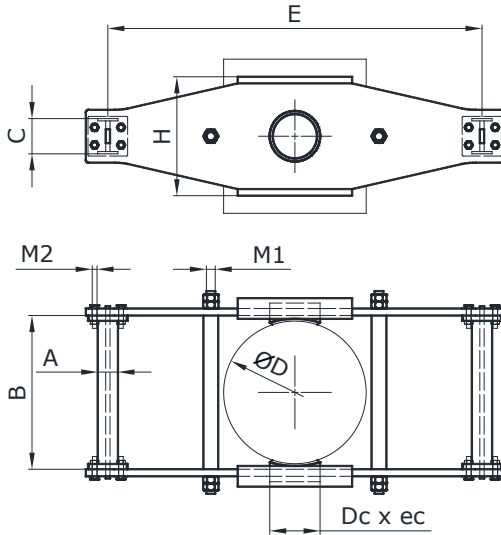

## DESIGNATION

**85-TU MS-DNK-E**

Example of designation: 85-45-550-950

TU – load-bearing capacity class

MS – material group code

E – required spacing of a pair of struts

## DIMENSIONS AND PARAMETERS: SERIES 1

Do	DNK	TU	Emin	Enom	Emax	A	B	C	H	M1	M2	Dc	m
mm	mm	-	mm	mm	mm	mm	mm	mm	mm	mm	mm	mm	kg
108	108	0 - 1	350	500	850	50	138	60	120	12	10	48	11,6
114	100	0 - 1	350	500	850	50	144	60	120	12	10	48	11,6
127	127	0 - 1	350	550	900	50	157	60	130	12	10	48	13,7
133	133	0 - 1	350	550	900	50	163	60	130	12	10	48	13,7
140	125	0 - 1	350	550	900	50	170	60	130	12	10	48	13,7
141	141	0 - 1	350	550	900	50	171	60	130	12	10	48	16,8
159	159	0 - 2	400	650	1000	60	189	80	150	12	10	60	22
168	150	0 - 2	400	650	1000	60	198	80	150	12	10	60	22
194	175	0 - 2	400	650	1000	70	224	100	180	16	12	76	26
219	200	0 - 2	480	700	1100	70	259	100	180	16	12	76	28
245	225	0 - 2	500	750	1100	70	285	100	180	16	12	89	30
273	250	0 - 2	550	800	1100	70	313	100	180	16	12	89	34
324	300	1 - 3	650	850	1200	80	364	120	200	16	12	114	39
356	350	1 - 3	660	950	1200	80	406	120	220	20	12	140	61
377	377	1 - 3	700	950	1200	80	427	120	220	20	12	140	61
406	400	1 - 3	820	1000	1300	90	451	140	220	20	16	140	64
426	426	1 - 3	840	1000	1300	90	471	140	220	20	16	140	65
457	450	1 - 3	850	1000	1300	90	502	140	220	20	16	140	65
508	500	1 - 3	900	1100	1500	100	573	160	260	24	16	168	87
530	530	1 - 3	950	1100	1500	100	595	160	260	24	16	168	88
559	550	1 - 3	980	1150	1500	100	624	160	260	24	16	168	92
610	600	1 - 3	1000	1200	1600	125	675	200	280	24	20	194	104
630	630	1 - 3	1050	1200	1600	125	695	200	280	24	20	194	105
660	650	1 - 3	1080	1200	1600	125	725	200	300	24	20	219	112
711	700	1 - 3	1200	1300	1700	140	776	200	300	30	20	219	122
720	720	1 - 3	1200	1200	1700	140	785	200	300	30	20	219	114
762	750	1 - 3	1250	1350	1700	140	827	200	320	30	20	245	134
813	800	1 - 3	1300	1400	1800	140	878	200	340	30	20	273	148
820	820	1 - 3	1320	1400	1800	140	885	200	340	30	20	273	148

Note: the dimensions and weights may vary, they are adapted to design loads and strut spacing in every individual case.



## DIMENSIONS AND PARAMETERS: SERIES 2

Do	DNK	TU	Emin	Enom	Emax	A	B	C	H	M1	M2	Dc	m
mm	mm	-	mm	mm	mm	mm	mm	mm	mm	mm	mm	mm	kg
108	108	2	350	500	850	50	138	60	140	12	12	48	19,3
114	100	2	350	500	850	50	144	60	140	12	12	48	19,3
127	127	2	350	550	900	50	157	60	150	12	12	48	23,2
133	133	2	350	550	900	50	163	60	150	12	12	48	23,2
140	125	2	350	550	900	50	170	60	150	12	12	48	23,2
141	141	2	350	550	900	50	171	60	150	12	12	48	29,6
159	159	3	400	650	1000	60	189	80	170	12	16	60	39
168	150	3	400	650	1000	60	198	80	170	12	16	60	39
194	175	3	400	650	1000	70	224	100	200	16	16	76	45
219	200	3	480	700	1100	70	259	100	200	16	16	76	49
245	225	3	500	750	1100	70	285	100	200	16	16	89	53
273	250	3	550	800	1100	70	313	100	200	16	16	89	55
324	300	4	650	850	1200	80	364	120	220	16	20	114	66
356	350	4	660	950	1200	80	406	120	240	20	20	140	108
377	377	4	700	950	1200	80	427	120	240	20	20	140	108
406	400	4	820	1000	1300	90	451	140	240	20	20	140	115
426	426	4	840	1000	1300	90	471	140	240	20	20	140	115
457	450	4	850	1000	1300	90	502	140	240	20	20	140	116
508	500	4	900	1100	1500	100	573	160	280	24	20	168	151
530	530	4	950	1100	1500	100	595	160	280	24	20	168	152
559	550	4	980	1150	1500	100	624	160	280	24	20	168	158
610	600	4	1000	1200	1600	125	675	200	300	24	20	194	176
630	630	4	1050	1200	1600	125	695	200	300	24	20	194	178
660	650	4	1080	1200	1600	125	725	200	320	24	20	219	189
711	700	4	1200	1300	1700	140	776	200	320	30	20	219	205
720	720	4	1200	1200	1700	140	785	200	320	30	20	219	192
762	750	4	1250	1350	1700	140	827	200	340	30	20	245	225
813	800	4	1300	1400	1800	140	878	200	360	30	20	273	246
820	820	4	1320	1400	1800	140	885	200	360	30	20	273	247

## DIMENSIONS AND PARAMETERS: SERIES 3

Do	DNK	TU	Emin	Enom	Emax	A	B	C	H	M1	M2	Dc	m
mm	mm	-	mm	mm	mm	mm	mm	mm	mm	mm	mm	mm	kg
108	108	3	350	500	850	60	138	80	160	12	12	48	25,3
114	100	3	350	500	850	60	144	80	160	12	12	48	25,3
127	127	3	350	550	900	60	157	80	170	12	12	48	29,9
133	133	3	350	550	900	60	163	80	170	12	12	48	29,9
140	125	3	350	550	900	60	170	80	170	12	12	48	29,9
141	141	3	350	550	900	60	171	80	170	12	12	48	41,4
159	159	4	400	650	1000	70	189	100	190	12	16	60	53
168	150	4	400	650	1000	70	198	100	190	12	16	60	53
194	175	4	400	650	1000	80	224	120	230	16	16	76	62
219	200	4	480	700	1100	80	259	120	230	16	16	76	68
245	225	4	500	750	1100	80	285	120	230	16	16	89	72
273	250	4	550	800	1100	80	313	120	230	16	16	89	78
324	300	5	650	850	1200	90	364	140	250	16	20	114	90
356	350	5	660	950	1200	90	406	140	280	20	20	140	143
377	377	5	700	950	1200	90	427	140	280	20	20	140	144
406	400	5	820	1000	1300	100	451	160	280	20	20	140	151
426	426	5	840	1000	1300	100	471	160	280	20	20	140	152
457	450	5	850	1000	1300	100	502	160	280	20	20	140	153
508	500	5	900	1100	1500	120	573	200	320	24	20	168	197
530	530	5	950	1100	1500	120	595	200	320	24	20	168	198
559	550	5	980	1150	1500	120	624	200	320	24	20	168	207
610	600	5	1000	1200	1600	140	675	220	350	24	20	194	235
630	630	5	1050	1200	1600	140	695	220	350	24	20	194	236
660	650	5	1080	1200	1600	140	725	220	370	24	20	219	250
711	700	5	1200	1300	1700	160	776	220	370	30	20	219	270
720	720	5	1200	1200	1700	160	785	220	370	30	20	219	254
762	750	5	1250	1350	1700	160	827	240	390	30	20	245	294
813	800	5	1300	1400	1800	160	878	240	410	30	20	273	321
820	820	5	1320	1400	1800	160	885	240	410	30	20	273	321

## MATERIAL GROUPS

MS No.	1	2	3	4	5	6	7
Tmax (°C)	350	500	580	400	620	350	350
Material	S235JR	16Mo3	10CrMo910	1.4301	1.4948	P275NH	P275NH

## PERMISSIBLE LOAD CORRECTION FACTORS AT THE TEMPERATURE KT,M (-) FOR TYPE 85:

MS / T (°C)	80	100	150	200	250	300	330	350	400	450	480	490	500	510	520	530	540	550	560	570	580	600		
1	1,00	1,00	1,00	1,00	1,00	0,94	0,83																	
2	1,00	1,00	1,00	1,00	1,00	1,00	1,00	1,00	1,00	1,00	0,98	0,86	0,69	0,57	0,45	0,37								
3									1,00	1,00	1,00	1,00	0,99	0,86	0,75	0,65	0,56	0,48	0,41					
4	1,00	1,00	1,00	1,00	1,00	0,93	0,90	0,89	0,86															
5	1,00	1,00	1,00	1,00	1,00	1,00	1,00	1,00	1,00	1,00	1,00	1,00	1,00											
6									0,87	0,84	0,83	0,81	0,81	0,80	0,80	0,78	0,78	0,78	0,77	0,75	0,75	0,65		
7	1,00	1,00	1,00	1,00	1,00	1,00	1,00	1,00	1,00															

## ALLOWABLE LOADS

The load-bearing capacity at higher temperatures and for other designed materials is checked, using the following formulas:  $F_{pT,M}^G = k_{v,M} \times F_{pT}$ , where the correction factor is determined, according to the above table. The permissible load for E spacing of pins other than E is determined, according to:  $F_p(E) = F_p \times E_{nom} / E$ .

## ASSEMBLY

The pipe clamp is assembled from its components in using the tongue-groove joints; all nuts are to be hand-tightened until they fully engage, and then they are to be secured with lock nuts. The attachment plate is secured against sliding away from the grooves by means of a shim plate that is secured with a bolt. This connection is tightened to a torque in (N\*m), corresponding to the bolt dimension M in (mm).

## 86

Clevis for the connection of the strut ball bushing joint of types 81 and 82, for welding to structure or to the side beams of a clamp type 85. Allowable angular deflection of the ball bushing joints is up to 6°. Used for static or cyclic load (alternating).

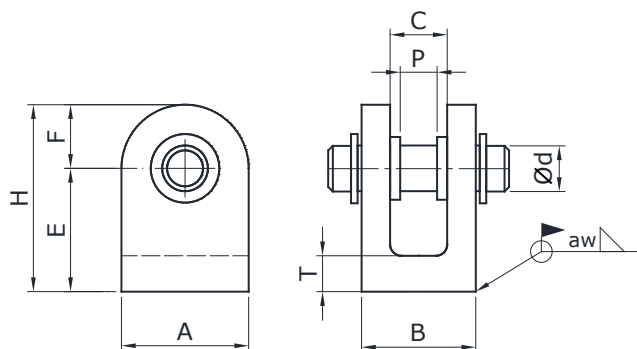

## DESIGNATION

## 86-TU

Example of designation: 86-4

TU – load-bearing capacity (connecting pin diameter code)

## DIMENSIONS AND PARAMETERS

TU	d	A	B	C	E	F	H	T	P	aw	m
-	mm	mm	(mm)	(mm)	(mm)	(mm)	(mm)	mm	mm	mm	kg
0	10	35	35	15	30	16	46	8	10	3	0,3
1	12	35,0	35	19	30	16	46	8	11	3	0,3
2	17	50,0	50	29	40	24	64	10	15	4	0,7
3	20	60,0	60	30	47	27	74	12	18	4	1,3
4	25	80,0	80	38	55	33	88	14	22,5	5	2,8
5	30	90	90	48	70	40	110	20	24,5	6	4,1
6	40	120	120	66	90	53	143	25	31	7	9,3
7	50	130	130	70	110	68	178	30	38	8	14,1
8	70	180	180	89	150	95	245	35	44	10	38,6

TU – load-bearing capacity, the permissible load see table on page 8-3.

## MATERIAL DESIGN

Carbon steel.

## ASSEMBLY

The clevises are welded to steel structure or clamps of type 85 with a continuous fillet. The pin must be secured with retention rings after installation. Washers inside the clevis limit the angular rotation of the strut ball bushing joint.

# 8

# SUPPORTS FOR NON-METALLIC AND INSULATED PIPING

## 8.1. INTRODUCTION

The supports for non-metallic and insulated piping presented in this catalogue are of lightweight design. They are manufactured of galvanized or hot-dip galvanized carbon steel or stainless steel. They are made of thin-wall steel sections and designed for the following conditions:

- Ambient temperature from -50 °C to +80 °C;
- Corrosive environment C1 to C4;
- For direct mounting on PP and PE pipe surfaces, according to DIN 8074 and DIN 8077;
- For direct mounting on PE or ALU cladding of PUR pipe insulation, according to EN 253 and other standards.

**Plastic pipes (PP, PE)** are very flexible with respect to the pipe diameter, and this flexibility (deformation) is time dependent. In order to avoid unacceptable sagging and deformations that tend to increase with the duration of loads, the supports need to be placed at relatively short distances. A high number of supports for a given pipe length leads to a requirement for a low unit weight of used supports, however, the supports usually do not restrain high loads. Therefore, it is recommended to use lightweight supports made from thin sections.

Friction has an adverse effect on the regularity of piping movements. Therefore, the friction should be minimized by the use of rollers or PTFE slide plates.

Support clamps with rubber lining are used for supporting piping – the rubber lining provides a reliable friction connection. A type 1 saddle can be used in cases where reduction of bending moment is required at the place of the support.

**Steel piping insulated with PUR insulation and with PE or ALU cladding** are supported either on saddles that wrap around the cladding (for low loads) or on saddles with load-bearing insulation filling, that is in contact with the steel pipe (for high loads or for restraints that transfer loads in the direction of pipe axis). This insulation filling has the same diameter as the insulation cladding. These two types of saddles are used to restrain small loads. Permissible loads for these saddles are limited by allowable specific load of the load bearing PUR insulation filler. Both types of saddles are then inserted into clamps of supports or hangers, with rubber lining.

The friction between the support base (a pipe shoe) and the steel element, that the support is placed on, can cause slipping between the clamp / saddle / pipe surface. Therefore, friction in the restraint that allows pipe movement should be minimized. Hot or cryogenic piping have usually high axial displacements at pipe support locations. Therefore, it is convenient to use rollers with a linear contact on the support base. This allows optimal utilization of support length for movement.

Roller supports can be designed in two ways:

- Saddle mounted directly on a V-shaped roller;
- Saddle placed in a clamped pipe shoe, which is installed on a PTFE slide plate or on a roller.

The first way of supporting can be used for all types of saddles and requires the two half-saddles to be connected with clamps of type P20.

## 8.2. SADDLES

Production group	Type	Characteristics and use
	1 Saddles for insulation cladding	Saddles mounted on insulation cladding, for low loads. Saddles made of hot-dip galvanized plate lined with rubber (EPDM) on inner side.
P1	2 Saddle with load-bearing insulation filler for supports and hangers of insulated pipes	Saddles with load-bearing insulation filler wrapped around the surface of steel pipe. Load-bearing foam glass filler wrapped from the outer side with a saddle made of hot-dip galvanized plate, with rubber (EPDM) lining on the inside of the saddle. One saddle is used under each clamp – two saddles are used for bolted base supports (pipe shoes).
	3 Anchor saddle	Saddles with load-bearing insulation filler enwrapping the steel pipe and with weld-on trunnions for transferring of forces in the direction of pipe axis. Load-bearing foam glass filler, wrapped from the outer side with a saddle made of hot-dip galvanized plate, with rubber (EPDM) lining on the inside of the saddle.

All saddles are attached to outer surface of insulation cladding or to steel pipe by assembling the half-saddles. The half-saddles are fixed with stainless steel tightening band.

The edges of a saddle must always protrude out of pipe clamps.

During the assembly of a saddle with load-bearing insulation filler, it is necessary to cut-out a section of the pipe insulation – in a zone corresponding to the length of the saddle. The surface of the insulation filler is covered with a new PE sheet that is bonded with the pipe insulation to create a moisture-tight and vapour-tight cover.

8.3. CLAMPS

Production group	Type	Characteristics and use
P2	0 Light clamp	Clamp for pipe shoes and for binding of saddles
	1 Two-bolt clamp	Clamp for hangers (uninsulated PP and PE). Inner surface of the clamp is lined with rubber.
	2 Three-bolt clamp	Clamp for single-rod hangers with higher loads (uninsulated PP and PE). Inner surface of the clamp is lined with rubber.
	3 Horizontal clamp	Clamp for single-rod hangers of horizontal pipes
	4 U-strap	Clamp for double-rod hangers of horizontal pipes

Clamps for PE and PP pipe hangers are attached directly to the surface of the pipe. Clamps for insulated pipes must be lined with saddles.

8.4. SUPPORT BASES (PIPE SHOES)

Production group	Type	Characteristics and use
P3	1 Sliding support	Light pipe shoe for a sliding support, with polished stainless-steel slide surface, or without surface finish of the sliding surface for use on rollers
	2 Support base for a V-roller	Light pipe shoe with V-shaped surface for roller guides
	3 Support base for a guide roller	Pipe shoe with a groove for roller guide (the pipe shoe is guided with a tongue-groove like connection)
	4 Anchor	Anchor base

Clamps for PE or PP pipe supports are attached directly to the pipe surface. Clamps for insulated pipes must be lined with saddles.

8.5. ROLLERS

Production group	Type	Characteristics and use
P4	1 Roller	Single cylinder roller for supports P31
	2 Roller with a tongue	Cylinder roller with guide for supports P33. Guides with specified gaps (from +/-2 to +/-10 mm).
	3 V-roller	Double cylinder roller (angled to form a V-shaped surface) with guide for supports P32. The restraint serves as a sliding support with a guide.
	4 Two-way roller	Roller for supports P34. The assembly serves as a support allowing movement in both horizontal directions.
	5 Two-way V-roller	Roller for supports P31. The assembly serves as a support allowing movement in both horizontal directions.

The rollers are made of galvanized steel. The roller bearing axes are made of stainless steel. As bearings for the rollers, bushings made of PTFE are fitted. The roller assembly is attached to the supporting structure with bolts.

8.6. ASSEMBLIES OF SUPPORT BASES

Sliding support

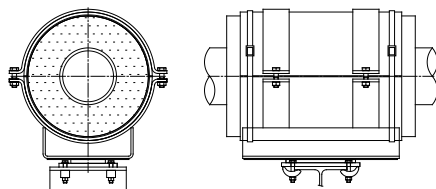

Support on a roller

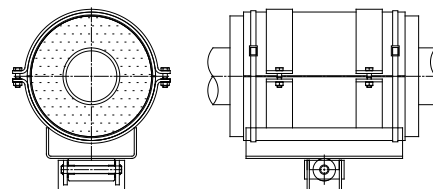

Support assembly for movement in both horizontal directions. In the direction perpendicular to pipe axis, the movement is limited to half of the difference between the width of the support base and the width of the PTFE plate or roller. A movement reserve of 25 mm in each direction must be kept.

Guided support with a V-roller

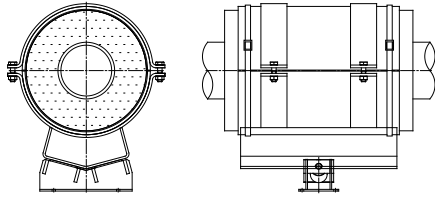

Guided support on a roller (the roller has a "tongue", the pipe shoe has a "groove")

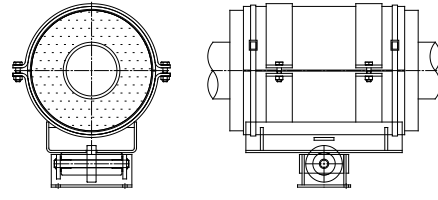

Guided pipe shoe assembly. If rollers with a tongue are used, a gap of  $\pm 2$  mm to  $\pm 10$  mm can be specified.

Support with a two-way V-roller

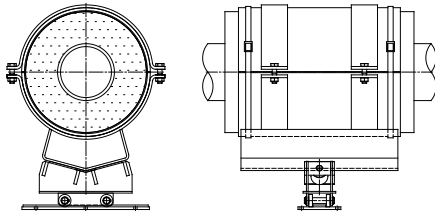

Support with a two-way stepped roller

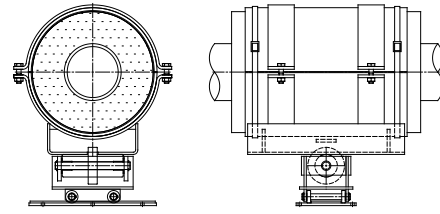

Roller support assembly allowing movement in both horizontal directions.

Anchor

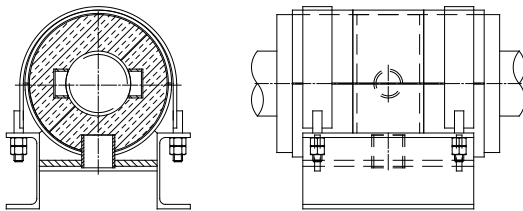

Assembly for fixed pipe support.

Guide with a V-roller

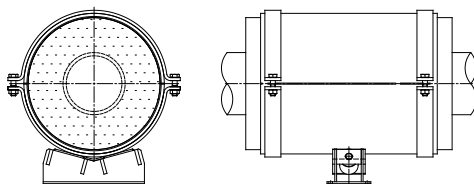

Roller guide for saddles (no pipe shoe used).

Support with a V-roller

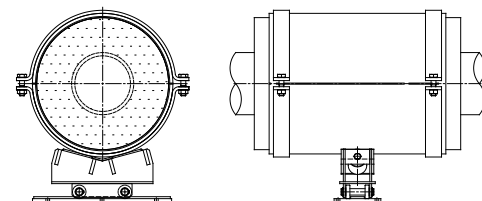

Roller support for saddles allowing movement in both horizontal directions (no pipe shoe used).

## P11

Steel saddle for direct installation on the surface of PUR pre-insulated pipes with PE/ALU cladding. It is used to distribute support loads from a hanger clamp or a support base (pipe shoe). The saddles are lined with rubber, which is shop-glued into both halves of the saddle. To facilitate the installation of the support, the saddle is tightened on both sides with stainless steel tightening band. The half saddles shall be assembled as seen on the picture below – i.e. the dividing plane of the saddle must be horizontal.

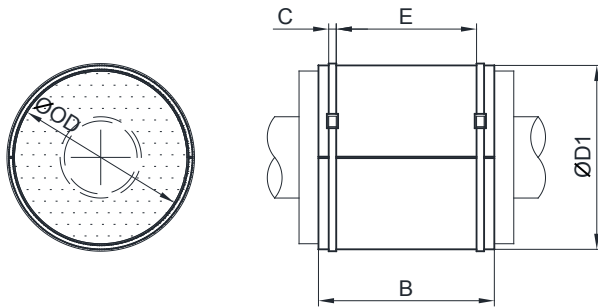

### DESIGNATION

#### P11-OD-M

OD – outer diameter of the pipe surface (insulation cladding)  
M – material group code

### DIMENSIONS AND PARAMETERS

OD	D1	B	C	E	F <sub>p</sub>	m
mm	mm	mm	mm	mm	kN	kg
090	94	200	6,4	180	1,9	0,27
110	115	220	6,4	200	2,5	0,72
125	130	220	6,4	200	2,9	0,81
140	145	250	6,4	230	3,7	1,02
160	165	300	6,4	280	5,0	1,40
180	185	300	6,4	280	5,7	1,6
200	205	350	12,7	280	7,4	2,0
225	231	350	12,7	330	8,3	3,4
250	256	400	12,7	380	10,5	4,3
280	286	400	12,7	380	11,8	4,9
315	321	450	12,7	430	14,9	6,1
355	361	450	12,7	430	16,8	6,9
400	408	500	12,7	480	21,0	11,5
450	458	550	12,7	530	26,0	14,2
500	508	600	12,7	580	31,5	17,2
560	568	650	12,7	630	38,2	20,9
630	638	650	12,7	630	43,0	23,5
670	678	700	12,7	680	49,2	26,8
710	718	750	12,7	730	55,9	30,5
800	808	750	12,7	730	63,0	34,3

F<sub>p</sub> – permissible saddle load, calculated from the load-bearing capacity of the PUR insulation filler.

### MATERIALS

Group 1 – Steel DX51D with zinc coating Z275-MAC

Group 2 – Steel 1.4301



## P12

Steel support saddle with load-bearing foam glass filler. The filler is installed on the surface of the inner pipe. It is used for hangers or support bases (bolted pipe shoes). If used on pipe shoes, one saddle is placed under each clamp. The load-bearing filler serves the purpose of distribution of higher loads from the support clamps. The inner segments of the load-bearing filler are made of foam glass; they are assembled on site and the gaps filled with a sealant. The saddle shell is made of steel plate and lined with rubber. In order to insert the load-bearing filler, it is necessary to make an assembly cut-out in the pipe insulation,

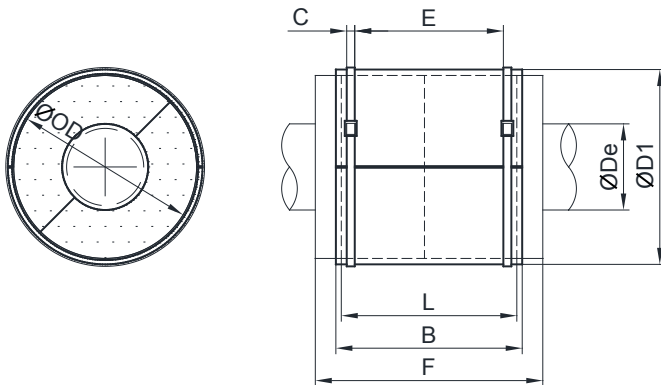

### DIMENSIONS AND PARAMETERS

OD	De	D1	B	C	E	L	Fp	m
mm	mm	mm	mm	mm	mm	mm	kN	kg
110	48,3	115	90	12,7	70	60	2,3	1,0
125	48,3	130	90	12,7	70	60	2,3	1,2
140	48,3	145	110	12,7	90	80	3,1	2,0
125	60,3	130	90	12,7	70	60	2,9	1,3
140	60,3	145	110	12,7	90	80	3,9	2,1
160	60,3	165	110	12,7	90	80	3,9	2,7
140	76,1	145	110	12,7	90	80	4,9	1,9
160	76,1	165	110	12,7	90	80	4,9	2,5
180	76,1	185	130	12,7	110	100	6,1	3,9
160	88,9	165	110	12,7	90	80	5,7	2,4
180	88,9	185	130	12,7	110	100	7,1	3,7
200	88,9	205	130	12,7	110	100	7,1	4,5
200	114,3	205	130	12,7	110	100	9,1	4,0
225	114,3	231	130	12,7	110	100	9,1	5,2
250	114,3	256	130	12,7	110	100	9,1	6,5
225	139,7	231	130	12,7	110	100	11,2	4,6
250	139,7	256	130	12,7	110	100	11,2	5,9
280	139,7	286	170	12,7	150	140	15,6	10,5
250	168,3	256	130	12,7	110	100	13,5	5,1
280	168,3	286	170	12,7	150	140	18,8	9,4
315	168,3	321	170	12,7	150	140	18,8	12,4
315	219,1	321	170	12,7	150	140	24,5	9,8

### MATERIALS OF SADDLE SHELL

Group 1 – Steel DX51D with zinc coating Z275-MAC  
Group 2 – Steel 1.4301

### MATERIALS OF LOAD-BEARING INSULATION FILLER AND INSULATION

FOAMGLASS F, pressure strength 1.6 MPa, thermal conductivity  $\leq 0.050$  W/(mK)  
PE strip of 1 mm thickness, shrink foil RL – COVALENCE WPC-C50

the length of the cut-out zone corresponds to the length of the saddle. The surface of the load-bearing foam glass filler is covered with a moisture-tight and vapour-tight PE strip, which is joined with the pipe cladding with a shrink foil. In order to simplify the installation of the support, the saddle is tightened on both sides with stainless steel tightening band. The half saddles must be assembled as seen on the picture below – i.e. the dividing plane of the saddle must be horizontal, the segments of the load-bearing filler must be turned by 90°.

### DESIGNATION

#### P11-OD-M

OD – outer diameter of the pipe surface (insulation cladding)  
M – material group code

OD	De	D1	B	C	E	L	Fp	m
mm	mm	mm	mm	mm	mm	mm	kN	kg
355	219,1	361	190	12,7	170	160	28,0	15,7
400	219,1	408	190	12,7	170	160	28,0	21
400	273	408	190	12,7	170	160	34,9	17
450	273	458	210	12,7	190	180	39,3	27
500	273	508	210	12,7	190	180	39,3	36
450	324	458	210	12,7	190	180	46,7	22
500	324	508	210	12,7	190	180	46,7	31
560	324	568	230	12,7	210	200	51,8	47
500	356	508	210	12,7	190	180	51,3	27
560	356	568	230	12,7	210	200	57,0	43
630	356	638	230	12,7	210	200	57,0	59
560	406	568	230	12,7	210	200	65,0	35
630	406	638	230	12,7	210	200	65,0	52
670	406	678	250	12,7	230	220	71,5	68
630	457	638	230	12,7	210	200	73,1	44
670	457	678	250	12,7	230	220	80,4	59
710	457	718	250	12,7	230	220	80,4	71
670	508	678	250	12,7	230	220	62,6	49,2
710	508	718	250	12,7	230	220	62,6	61,2
800	508	808	280	12,7	260	250	71,1	102,8
800	610	808	280	12,7	260	250	85,4	75,9
900	610	912	280	12,7	260	250	85,4	117,6
1000	610	1012	280	12,7	260	250	85,4	164,0

$F_p$  – permissible saddle load, calculated from the load-bearing capacity of the saddle insulation filler

$F = B + 100$  mm – width of the overlap of the pipe insulation with shrink foil

## P13

Steel support saddle with load-bearing foam glass filler. The filler is installed on the surface of the steel inner pipe. For transfer of axial forces, there are two trunnions welded on the steel inner pipe. Used for hangers or support bases (bolted pipe shoes). If used on pipe shoes, one saddle is placed under each clamp. The load-bearing filler serves the purpose of distribution of higher loads from the anchor base. The inner segments of the load-bearing filler are made of foam glass; they are assembled on site on the welded trunnions and the gaps filled with a sealant. The

saddle shell is made of steel plate and lined with rubber and there is a third trunnion that sticks out of the saddle shell at the bottom – this trunnion serves the purpose of transferring the loads to the anchor base. In order to insert the load-bearing filler, it is necessary to make an assembly cut-out in the pipe insulation, the length of the cut-out zone corresponds to the length of the saddle. The surface of the load-bearing foam glass filler is covered with a moisture-tight and vapour-tight PE strip, which is joined with the pipe cladding with a shrink foil.

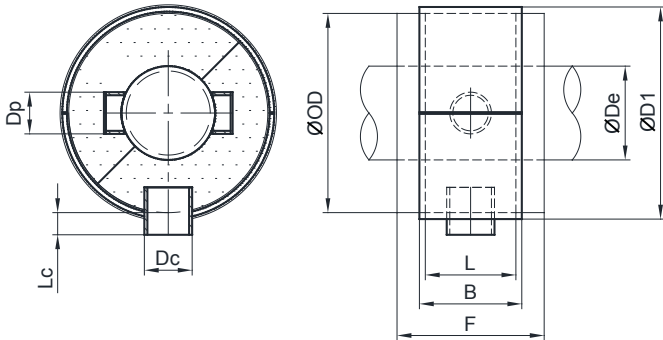

## DIMENSIONS AND PARAMETERS

OD	De	D1	Dp	Dc	Lc	B	L	Fp	Fpx*	m
mm	mm	mm	mm	mm	mm	mm	mm	kN	kN	kg
200	114,3	205	48,3	60,3	30	160	120	7,7	2,0	5,3
225	114,3	231	48,3	60,3	30	160	120	7,7	2,0	6,7
250	114,3	256	48,3	60,3	30	160	120	7,7	2,0	8,3
225	139,7	231	48,3	60,3	30	160	120	9,4	2,0	6,0
250	139,7	256	48,3	60,3	30	160	120	9,4	2,0	7,6
280	139,7	286	48,3	60,3	35	160	120	9,4	2,4	9,7
250	168,3	256	60,3	76,1	30	180	140	13,2	2,6	7,7
280	168,3	286	60,3	76,1	35	180	140	13,2	3,0	10,1
315	168,3	321	60,3	76,1	40	180	140	13,2	3,4	13,3
315	219,1	321	76,1	88,9	40	190	150	18,4	4,0	11,7
355	219,1	361	76,1	88,9	40	190	150	18,4	4,0	15,9
400	219,1	408	76,1	88,9	40	190	150	18,4	4,0	21
400	273	408	88,9	114,3	40	220	180	27,5	5,1	21
450	273	458	88,9	114,3	40	220	180	27,5	5,1	29
500	273	508	88,9	114,3	40	220	180	27,5	5,1	37
450	324	458	114,3	139,7	40	240	200	36,3	6,3	27
500	324	508	114,3	139,7	40	240	200	36,3	6,3	36
560	324	568	114,3	139,7	40	240	200	36,3	6,3	49
500	356	508	139,7	168,3	45	240	200	39,9	8,5	33
560	356	568	139,7	168,3	45	280	240	47,8	8,5	54
630	356	638	139,7	168,3	45	280	240	47,8	8,5	74
560	406	568	139,7	168,3	45	280	240	54,6	8,5	46
630	406	638	139,7	168,3	45	280	240	54,6	8,5	66
670	406	678	139,7	168,3	45	280	240	54,6	8,5	78
630	457	638	168,3	168,3	45	280	240	61,4	8,5	56
670	457	678	168,3	168,3	45	280	240	61,4	8,5	69
710	457	718	168,3	168,3	45	280	240	61,4	8,5	82
670	508	678	168,3	168,3	50	280	240	68,3	9,4	58
710	508	718	168,3	168,3	50	280	240	68,3	9,4	71
800	508	808	168,3	168,3	50	280	240	68,3	9,4	103
800	610	808	219,1	219,1	50	320	280	95,6	12,3	92
900	610	912	219,1	219,1	50	320	280	95,6	12,3	139
1000	610	1012	219,1	219,1	50	320	280	95,6	12,3	191

$F_p$  – permissible saddle load in the y- and z-axis, calculated from the load-bearing capacity of the saddle insulation filler. The relation between the y and z forces is:  $F_y/F_p + F_z/F_p \leq 1$ .

$F_{px}^*$  – basic load-bearing capacity in the direction of pipe axis. The permissible force is calculated for each load case, according to formula  $F_{px} = F_{px}^* + 0,3 \times F_z$ , where  $F_z$  is the actual load of the restraint in vertical direction.

$F = B + 100$  mm – width of the overlap of the pipe insulation with shrink foil.

## MATERIALS OF SADDLE SHELL

Group 1 – Steel DX51D with zinc coating Z275-MAC  
Group 2 – Steel 1.4301

## MATERIALS OF LOAD-BEARING INSULATION FILLER AND INSULATION

FOAMGLASS F, pressure strength 1.6 MPa, thermal conductivity  $\leq 0.050$  W/(mK).

PE strip of 1 mm thickness, shrink foil RL – COVALENCE WPC-C50.

## P20

Light clamp for pipe shoes and for binding of saddles for horizontal uninsulated PE/PP pipes or insulated pipes with saddle of type P11.

### DESIGNATION

#### P20-OD-M

OD – outer diameter of pipe or saddle

M – material group code

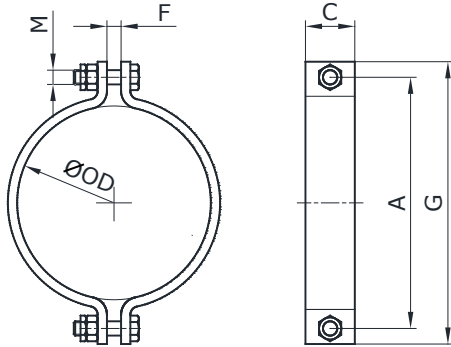

### DIMENSIONS AND PARAMETERS

OD	A	G	C	F	M	m
mm	mm	mm	mm	mm	mm	kg
90	118	134	30	6	6	0,26
110	145	165	40	8	8	0,56
125	161	181	40	8	8	0,62
140	176	196	40	8	8	0,68
160	198	218	40	10	8	0,94
180	218	238	40	10	8	1,04
200	238	258	40	10	8	1,14
225	273	301	50	12	10	1,94
250	298	326	50	12	10	2,1
280	329	357	50	12	10	2,3
315	364	392	50	12	10	2,6
355	404	432	50	12	10	2,9
400	454	486	60	12	12	4,0
450	505	537	60	12	12	4,4
500	559	591	60	12	12	6,4
560	619	651	60	12	12	7,1
630	689	721	60	12	12	8,0
670	729	761	60	12	12	8,4
710	769	801	60	12	12	8,9
800	860	892	60	12	12	10,0

### MATERIAL GROUPS

1 – Steel S235JR with zinc coating Z275

2 – Steel 1.4301

## P21

Two-bolt clamp for horizontal uninsulated PE/PP pipes or insulated pipes with saddle of type P11. Connection to the rod via eye nut. The clamps are lined with rubber, which is shop-glued on to both half-clamps.

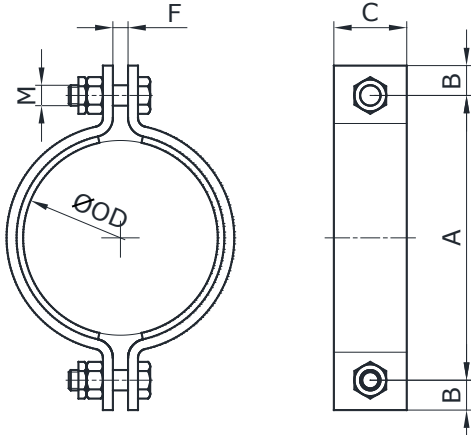

### DESIGNATION

#### P21-OD-M

OD – outer diameter of pipe or saddle

M – material group code

### DIMENSIONS AND PARAMETERS

OD	A	B	C	F	M	F <sub>p</sub>	m
mm	mm	mm	mm	mm	mm	kN	kg
25	63	11	30	7	10	2,9	0,33
35	77	11	30	7	10	2,9	0,37
40	82	11	30	7	10	2,9	0,39
50	103	11	40	9	10	3,5	0,64
63	121	11	40	9	10	3,5	0,74
75	128	11	40	9	10	3,5	0,78
90	173	11	40	9	10	3,5	0,9
110	193	13	50	11	12	6,2	1,8
125	208	13	50	11	12	6,2	2,0
140	227	13	50	11	12	6,2	2,2
160	237	13	50	11	12	6,2	2,3
180	263	13	50	11	12	6,2	2,5
200	290	17	60	17	16	9,3	3,3
225	327	17	60	17	16	9,3	3,5
250	357	17	60	17	16	8,3	3,9
280	372	17	60	17	16	7,8	4,1
315	409	17	60	17	16	6,9	4,5
355	454	17	60	17	16	6,1	5,0
400	515	17	70	23	16	10,0	8,1
450	566	17	70	23	16	8,9	9,0
500	617	17	70	23	16	8,0	9,8
560	707	17	90	28	16	12,3	21
630	782	21	90	28	20	18,3	24
670	823	21	90	28	20	17,2	26
710	863	21	90	28	20	16,2	27
800	954	21	90	28	20	14,4	30

F<sub>p</sub> – permissible load of the clamp transferred to hanger rod

### MATERIAL GROUPS

1 – Steel S235JR with zinc coating Z275

2 – Steel 1.4301

## P22

Three-bolt clamp for hangers with higher loads used for horizontal non-insulated PE/PP pipes or insulated pipes with saddle of type P12. Connection to the rod nut eye. The clamps are lined with rubber, which is shop glued on to both halves.

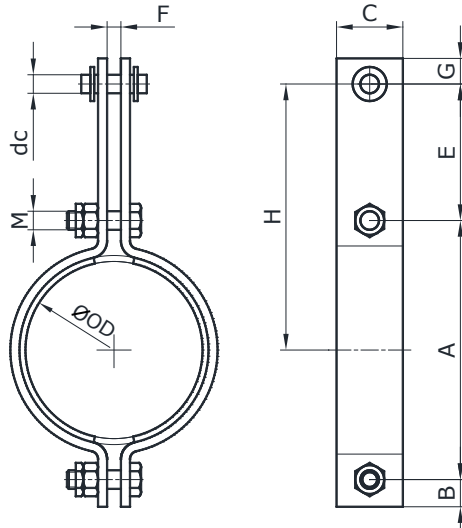

### DESIGNATION

#### P22-OD-M

OD – outer diameter of pipe or saddle

M – material group code

### DIMENSIONS AND PARAMETERS

OD	A	B	C	G	H	E	F	M	dc	F <sub>p</sub>	m
mm	mm	mm	mm	mm	mm	mm	mm	mm	mm	kN	kg
40	82	15	30	14	81	40	7	10	10	6,5	0,50
50	99	15	50	17	100	50	9	10	12	9,4	1,1
63	117	15	50	17	109	50	9	10	12	9,4	1,2
75	123	15	50	17	112	50	9	10	12	9,4	1,2
90	154	15	50	17	127	50	9	10	12	9,4	1,4
110	181	18	60	17	161	70	11	12	12	7,7	2,8
125	196	18	60	22	168	70	11	12	16	16,2	3,0
140	215	18	60	22	178	70	11	12	16	14,3	3,2
160	225	18	60	22	183	70	11	12	16	13,4	3,3
180	251	18	60	22	196	70	11	12	16	11,6	3,6
200	289	24	80	22	215	70	17	16	16	13,9	5,1
225	314	24	80	28	237	80	17	16	20	12,4	5,7
250	344	24	80	28	252	80	17	16	20	11,0	6,1
280	372	30	100	28	260	80	17	20	20	13,0	8,8
315	409	30	100	28	278	80	17	20	20	11,5	9,5
355	454	30	100	28	301	80	17	20	20	10,1	10,4
400	515	36	120	28	345	100	23	24	20	17,1	17,8
450	566	36	120	28	370	100	23	24	20	15,2	19,3
500	617	36	120	34	396	100	23	24	24	13,6	21
560	685	36	120	34	440	110	28	24	24	27,6	34
630	760	36	120	34	484	110	28	24	24	24,3	37
670	801	36	120	34	504	110	28	24	24	22,9	39
710	841	36	120	34	524	110	28	24	24	21,6	41
800	932	36	120	34	570	110	28	24	24	19,1	45

F<sub>p</sub> – permissible load of the clamp transferred to hanger rod

### MATERIAL GROUPS

1 – Steel S235JR with zinc coating Z275

2 – Steel 1.4301

## P23

Clamp for hangers of horizontal uninsulated PE/PP pipes or insulated pipes with saddle of type P13. Connection to threaded rod.

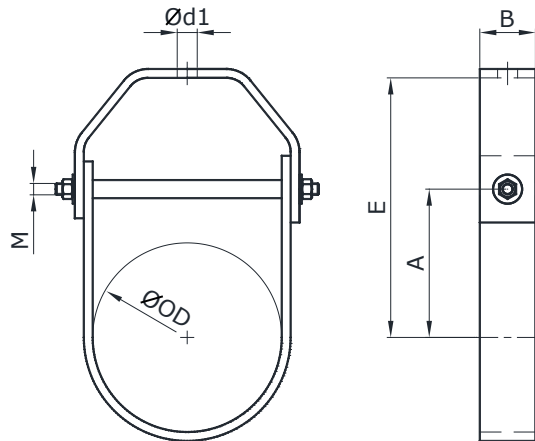

### DESIGNATION

#### P23-OD-M

OD – outer diameter of pipe or saddle

M – material group code

### DIMENSIONS AND PARAMETERS

OD	A	B	E	M	d1	F <sub>p</sub>	m	tl. izol.
mm	mm	mm	mm	mm	mm	kN	kg	mm
40	70	50	86	10	14	3,7	0,75	40
50	80	50	100	10	14	3,7	0,9	40
63	90	50	115,2	10	14	3,7	1,0	40
75	100	50	130	10	14	3,7	1,1	50
90	110	50	146	10	14	3,7	1,2	50
110	120	60	164	12	18	5,3	2,3	50
125	130	60	180	12	18	5,3	2,6	50
140	140	60	196	12	18	5,3	2,8	50
160	160	80	224	12	18	5,3	4,2	60
180	170	80	242	12	18	5,3	4,5	60
200	180	80	260	12	18	5,3	4,9	60
225	190	80	280	16	22	9,4	5,5	60
250	210	100	310	16	22	9,4	9,4	60
280	220	100	332	16	22	9,4	10,2	60
315	240	100	366	16	22	9,4	11,3	60
355	260	100	402	16	22	9,4	12,4	60
400	280	100	440	16	22	9,4	13,7	60
450	310	100	490	16	22	9,4	15,2	60
500	350	100	550	20	26	14,7	20	80
560	380	100	604	20	26	14,7	23	80
630	420	100	672	20	26	14,7	25	80
670	440	100	708	20	26	14,7	26	80
710	460	100	744	20	26	14,7	28	80
800	500	100	820	20	26	14,7	31	80

F<sub>p</sub> – permissible load of the clamp transferred to hanger rod

### MATERIAL GROUPS

1 - Steel S235JR with zinc coating Z275

2 - Steel 1.4301

## P24

U-strap clamp used for double-rod hangers of horizontal insulated pipes with saddle of type P13. Connection to hanger rods via clevis and pin. The clamp is lined with rubber.

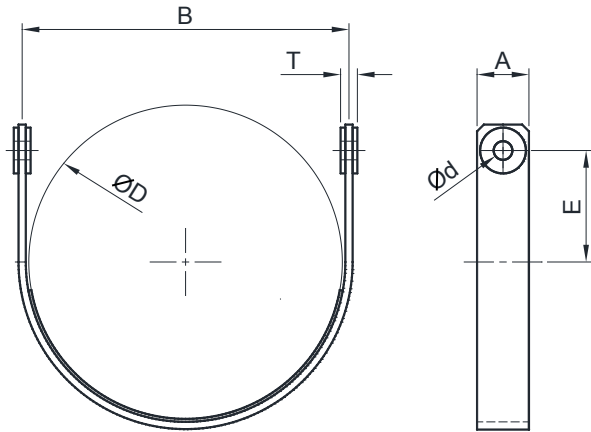

### DESIGNATION

#### P24-OD-M

OD – outer diameter of pipe or saddle

M – material group code

### DIMENSIONS AND PARAMETERS

OD	A	B	E	T	d	F <sub>p</sub>	m
mm	mm	mm	mm	mm	mm	kN	kg
400	100	412	200	18	10	26,3	5,4
450	100	462	225	18	10	26,3	6,1
500	100	512	250	18	10	26,3	6,7
560	100	572	280	18	10	26,3	7,5
630	120	644	315	22	12	39,5	13,3
670	120	684	335	22	12	39,5	14,1
710	120	726	355	22	12	39,5	15,0
800	120	816	400	22	12	39,5	16,8
900	140	918	450	26	15	59,2	27
1000	140	1018	500	26	15	59,2	30

F<sub>p</sub> – permissible load of the clamp transferred to hanger rod

### MATERIAL GROUPS

1 - Steel S235JR with zinc coating Z275

2 - Steel 1.4301

## P31

Light pipe shoe for a sliding support, with polished stainless-steel slide surface, or without surface finish of the sliding surface for use on rollers. The clamps are lined with rubber, which is shop-glued on to both half-clamps.

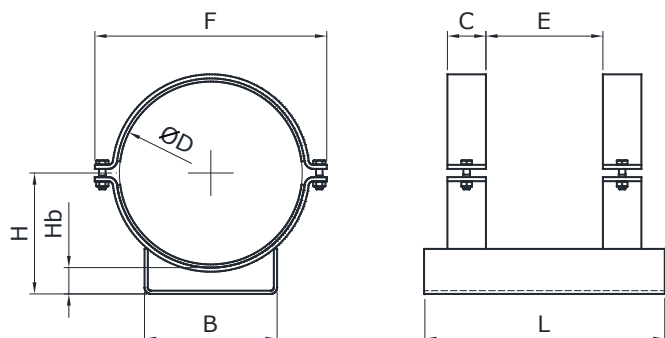

## DESIGNATION

## P31-OD-M

OD – outer diameter of pipe or saddle  
M – material group code

## DIMENSIONS AND PARAMETERS

OD	H	B	L	Hb	C	E	F	F <sub>p</sub>	m
mm	mm	mm	mm	mm	mm	mm	mm	kN	kg
25	41	40	180	29	30	60	68	9,5	0,7
35	55	50	180	38	30	60	80	9,5	0,8
40	59	50	180	39	30	60	85	9,5	0,8
50	72	60	180	47	30	60	97	12,9	1,2
63	81	60	180	50	30	60	111	12,9	1,3
75	95	80	180	58	30	60	123	12,0	1,6
90	104	80	190	59	30	70	138	12,1	1,7
110	117	80	220	62	40	60	170	16,1	2,5
125	125	80	220	63	40	60	186	16,1	2,6
140	133	80	240	63	40	80	201	16,2	2,8
160	145	80	270	65	40	110	223	16,3	3,5
180	155	120	270	65	40	110	243	22,0	4,6
200	166	120	270	66	40	110	263	22,0	4,8
225	180	120	330	68	50	130	307	27,7	6,9
250	193	120	360	68	50	160	333	27,7	7,6
280	208	120	360	68	50	160	363	27,7	8,0
315	244	160	390	87	50	190	398	32,0	11,0
355	264	160	390	87	50	190	438	32,0	11,6
400	288	160	450	88	60	210	494	38,4	14,6
450	314	160	480	89	60	240	545	38,5	15,9
500	359	210	510	109	60	270	599	35,2	22,6
560	390	210	550	110	60	310	659	35,3	24,8
630	425	210	550	110	60	310	729	35,3	26
670	445	300	580	110	60	340	769	52,6	35
710	466	300	580	111	60	340	809	52,6	36
800	511	300	580	111	60	340	900	52,6	38

F<sub>p</sub> – permissible support load in vertical direction

## MATERIAL DESIGN

1 – Steel S235JR with zinc coating Z275  
2 – Steel 1.4301

## SLIDING SURFACES

S – support base without sliding treatment, for mounting on rollers  
M – with stainless steel mirror finish of the sliding surface.



## P32

Light pipe shoe with a V-shaped bottom side for mounting on the V-roller guide. The clamps are lined with rubber, which is shop-glued on to both half-clamps.

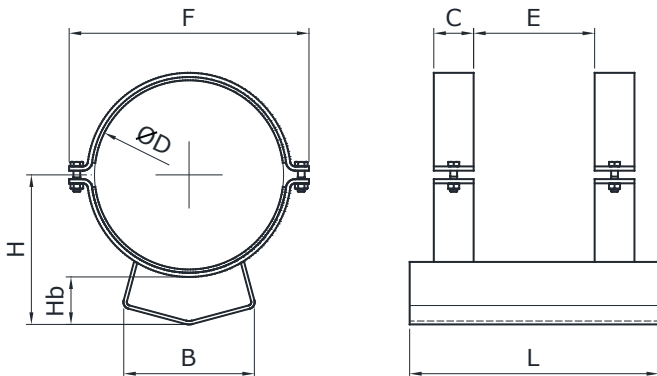

### DESIGNATION

#### P32-OD-M

OD – outer diameter of pipe or saddle  
M – material group code

### DIMENSIONS AND PARAMETERS

OD	H	B	L	Hb	C	E	F	F <sub>p</sub>	m
mm	mm	mm	mm	mm	mm	mm	mm	kN	kg
75	95	80	300	58	30	270	123	11,8	2,3
90	104	80	300	59	30	270	138	11,8	2,4
110	117	80	300	62	40	260	170	15,7	3,0
125	125	80	300	63	40	260	186	15,7	3,1
140	131	120	360	61	40	320	201	17,1	4,7
160	144	120	360	64	40	320	223	17,1	5,2
180	155	120	360	65	40	320	243	21,3	5,4
200	166	120	360	66	40	320	263	21,3	5,6
225	200	160	400	87	50	350	307	26,6	8,2
250	212	160	400	87	50	350	333	26,6	8,6
280	227	160	400	87	50	350	363	26,6	9,0
315	263	160	400	105	50	350	398	28,8	10,2
355	283	200	400	105	50	350	438	30,7	12,5
400	305	200	400	105	60	340	494	36,9	14,6
450	330	200	400	105	60	340	545	36,9	15,5
500	360	250	400	110	60	340	599	33,8	21
560	390	280	400	110	60	340	659	33,8	23
630	425	300	400	110	60	340	729	33,8	25
670	445	300	400	110	60	340	769	50,1	29
710	465	340	400	110	60	340	809	50,1	31
800	510	380	400	110	60	340	900	50,1	34

F<sub>p</sub> – permissible support load in vertical direction

### MATERIAL DESIGN

- 1 – Steel S235JR with zinc coating Z275
- 2 – Steel 1.4301

## P33

Light pipe shoe with a groove for mounting on roller with a tongue. The assembly works as a guide support (the pipe shoe is guided with a tongue-groove like connection), the gap is in the range from  $\pm 2$  mm to  $\pm 10$  mm, the value of required gap must be specified. Axial movement in the range of A-25 mm. The clamps are lined with rubber, which is shop-glued onto both half-clamps.

## DESIGNATION

## P33-OD-M-G

OD – outer diameter of pipe or saddle

M – material group code

G – groove width (determines the guide gap)

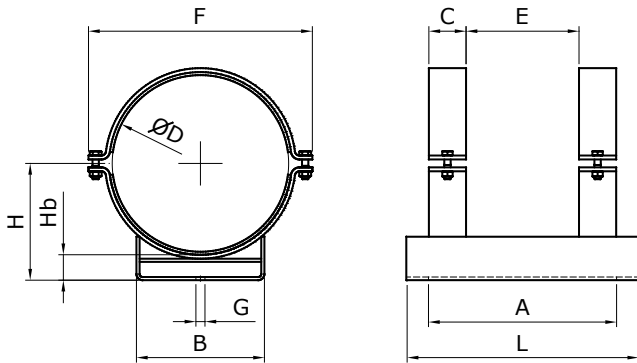

## DIMENSIONS AND PARAMETERS

OD	H	B	L	Hb	C	E	F	G	A	F <sub>p</sub>	m
mm	mm	mm	mm	mm	mm	mm	mm	mm	mm	kN	kg
25	41	40	180	29	30	60	68	10	100	9,5	0,7
35	55	50	180	38	30	60	80	10	100	9,5	0,8
40	59	50	180	39	30	60	85	10	100	9,5	0,8
50	72	60	180	47	30	60	97	10	100	12,9	1,2
63	81	60	180	50	30	60	111	10	100	12,9	1,3
75	95	80	180	58	30	60	123	12	100	12,0	1,6
90	104	80	190	59	30	70	138	12	100	12,1	1,7
110	117	80	220	62	40	60	170	12	130	16,1	2,5
125	125	80	220	63	40	60	186	12	130	16,1	2,6
140	133	80	240	63	40	80	201	12	130	16,2	2,8
160	145	80	270	65	40	110	223	12	130	16,3	3,5
180	155	120	270	65	40	110	243	18	130	22,0	4,6
200	166	120	270	66	40	110	263	18	130	22,0	4,8
225	180	120	330	68	50	130	307	18	180	27,7	6,9
250	193	120	360	68	50	160	333	18	180	27,7	7,6
280	208	120	360	68	50	160	363	18	180	27,7	8,0
315	244	160	390	87	50	190	398	24	180	32,0	11,0
355	264	160	390	87	50	190	438	24	180	32,0	11,6
400	288	160	450	88	60	210	494	24	200	38,4	14,6
450	314	160	480	89	60	240	545	24	200	38,5	15,9
500	359	210	510	109	60	270	599	30	200	35,2	22,6
560	390	210	550	110	60	310	659	30	200	35,3	24,8
630	425	210	550	110	60	310	729	30	200	35,3	26
670	445	300	580	110	60	340	769	30	200	52,6	35
710	466	300	580	111	60	340	809	30	200	52,6	36
800	511	300	580	111	60	340	900	30	200	52,6	38

F<sub>p</sub> – permissible support load in vertical direction

## MATERIAL GROUPS

1 – Steel S235JR with zinc coating Z275

2 – Steel 1.4301

## P34

Anchor base for saddles type P13, connected to steel pipe by means of welded trunnions.

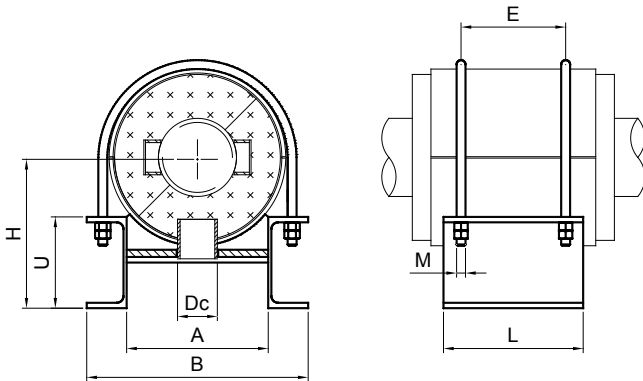

### DESIGNATION

#### P34-OD-Dc-M

OD – outer diameter of pipe or saddle

Dc – outer diameter of trunnion

M – material group code

### DIMENSIONS AND PARAMETERS

OD	H	B	L	A	U	M	E	m
mm	mm	mm	mm	mm	mm	mm	mm	kg
200	166	260	200	168	100	16	160	9,6
225	180	297	200	193	120	16	160	11,6
250	193	312	200	208	120	16	160	12,4
280	208	340	200	236	120	16	160	13,9
315	244	384	220	268	140	20	180	21
355	264	430	220	302	160	20	180	25
400	288	480	230	340	180	20	190	29
450	314	550	260	398	200	20	220	40
500	359	591	260	427	220	20	220	45
560	390	651	280	487	220	20	240	54
630	425	732	320	552	240	24	280	84
670	445	772	320	592	240	24	280	92
710	466	812	320	632	240	24	280	100
800	511	902	320	722	240	24	280	119

$F_p$  – permissible load of the support in both vertical and horizontal direction is identical with P13 saddles

### MATERIAL GROUPS

1 – Steel S235JR with zinc coating Z275

2 – Steel 1.4301

## P41

Roller used under pipe shoes allowing movement in both horizontal directions. The equivalent friction coefficient calculated from rolling resistance in axial direction is  $f = 0.04$ . The rollers are made of galvanized steel. The roller bearing axles are made of stainless steel. As bearings for the rollers, bushings made of PTFE are fitted. The roller assembly is attached to the supporting structure with bolts.

### DESIGNATION

#### P41-VEL

VEL – Roller size

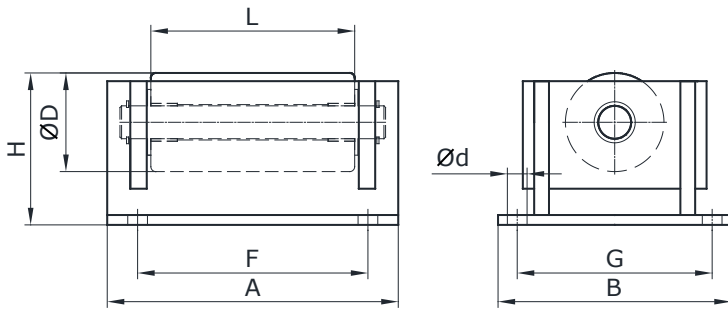

### DIMENSIONS AND PARAMETERS

Size/VEL	D	H	L	A	B	F	G	d	F <sub>p</sub>	m
-	mm	mm	mm	mm	mm	mm	mm	mm	kN	kg
1	40	55	50	95	112	60	92	9	5,3	1,9
2	50	65	80	135	126	93	106	9	8,4	4,1
3	60	85	100	180	150	119	126	12	12,4	8,9
4	80	105	150	160	180	170	156	12	21,1	15,5
5	80	110	180	180	190	200	162	14	54,0	18,1
6	90	125	200	305	230	225	194	18	75,5	36,2

F<sub>p</sub> – permissible load in vertical direction

### MATERIALS

Steel S235JR with zinc coating Z275

## P42

Roller with a tongue, for insertion under pipe shoes used as guided supports. It limits movement perpendicular to the pipe axis. The equivalent slide friction coefficient, calculated from rolling resistance in axial direction, is  $f = 0.04$ . The rollers are made of galvanized steel. The roller bearing axles are made of stainless steel. As bearings for the rollers, bushings made of PTFE are fitted. The roller assembly is attached to the supporting structure with bolts.

### DESIGNATION

#### P42-VEL

VEL – Roller size

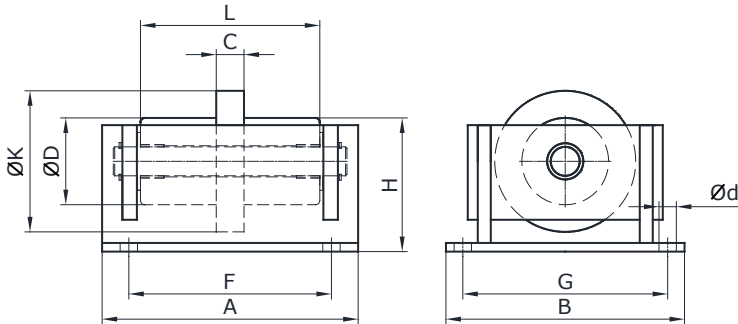

### DIMENSIONS AND PARAMETERS

Size/VEL	D	K	C	H	L	A	B	F	G	d	F <sub>p</sub>	m
-	mm	mm	mm	mm	mm	mm	mm	mm	mm	mm	kN	kg
1	40	50	8	55	50	95	112	60	92	9	5,3	2,1
2	50	55	10	65	80	135	126	93	106	9	8,4	4,7
3	60	75	14	85	100	180	150	119	126	12	12,4	9,4
4	80	95	25	105	150	160	180	170	156	12	21,1	16,2
5	80	105	25	110	180	180	190	200	162	14	54,0	18,9
6	90	115	30	125	200	305	230	225	194	18	75,5	38

F<sub>p</sub> – permissible load of the support in both vertical and horizontal direction is identical with P13 saddles

### MATERIAL DESIGN

1 – Steel S235JR with zinc coating Z275

2 – Steel 1.4301

## P43

Double cylinder V-roller (the rollers are angled to form a V-shaped surface), for insertion under pipe shoes or saddles. It limits movement perpendicular to the pipe axis. The equivalent slide friction coefficient, calculated from rolling resistance in axial direction, is  $f = 0.04$ . The rollers are made of galvanized steel. The roller bearing axles are made of stainless steel. As bearings for the rollers, bushings made of PTFE are fitted. The roller assembly is attached to the supporting structure with bolts.

### DESIGNATION

#### P43-VEL

VEL – Roller size

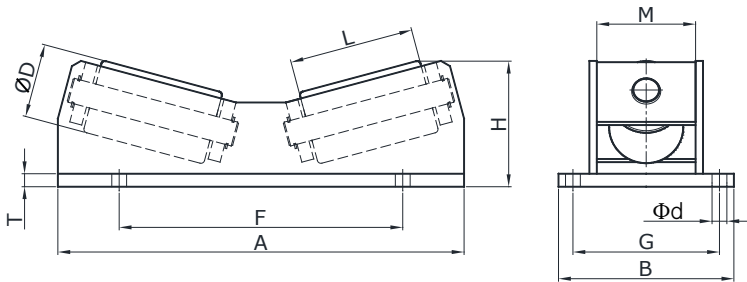

### DIMENSIONS AND PARAMETERS

Size/VEL	D	H	L	A	B	F	G	d	F <sub>p</sub>	m
-	mm	mm	mm	mm	mm	mm	mm	mm	kN	kg
1	40	75	50	200	112	125	92	9	8,0	4,4
2	50	85	60	220	126	125	106	9	12,6	7,7
3	60	105	80	350	150	250	126	12	18,6	16,5
4	80	140	120	450	180	320	156	12	31,7	38,3
5	80	160	140	460	190	350	162	14	81,0	51

F<sub>p</sub> – permissible load in vertical direction

### MATERIAL DESIGN

Steel S235JR with zinc coating Z275

## P44

Double roller with a tongue, for insertion under pipe shoes P33, bidirectional roller bearing. Upper part for axial movement is made up of a roller type P42, lower part for lateral movement consists of 2 rollers that roll on an anchor plate with a tongue that acts as a guide of the rollers.

The equivalent slide friction coefficient, calculated from rolling resistance in axial direction, is  $f = 0.04$ . The rollers are made of galvanized steel. The roller bearing axles are made of stainless steel. As bearings for the rollers, bushings made of PTFE are fitted.

### DESIGNATION

#### P44-VEL

VEL – Roller size

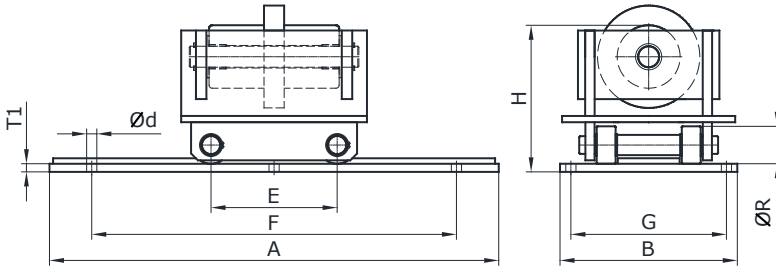

### DIMENSIONS AND PARAMETERS

Size/VEL	H	A	B	F	G	E	R	T1	d	F <sub>p</sub>	y <sub>max</sub>	m
-	mm	mm	mm	mm	mm	mm	mm	mm	mm	kN	mm	kg
1	93	270	130	170	110	78	26	6	10	5,3	85	2,1
2	110	310	170	190	147	93	31	8	10	8,4	85	10,9
3	139	330	215	190	190	108	36	10	12	12,4	85	21,3
4	177	380	270	230	245	147	49	15	12	21,1	85	36,8
5	195	410	305	250	277	180	60	15	14	54,0	85	46,7

Other dimensions as the P42 type

y<sub>max</sub> – maximum movement in lateral direction

F<sub>p</sub> – permissible load in vertical direction

### MATERIAL DESIGN

Steel S235JR with zinc coating Z275

## P45

V-roller for insertion under pipe shoe type 32 or saddles. It limits movement perpendicular to the pipe axis. Upper part for axial movement is made up of a roller type P43, lower part for lateral movement consists of 2 rollers that roll on an anchor plate with a tongue that acts as a guide of the rollers. The equivalent slide friction coefficient, calculated from rolling resistance in axial direction, is  $f = 0.04$ . The rollers are made of galvanized steel. The roller bearing axles are made of stainless steel. As bearings for the rollers, bushings made of PTFE are fitted.

### DESIGNATION

#### P45-VEL

VEL – Roller size

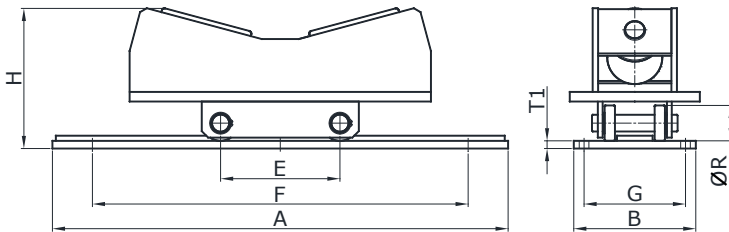

### DIMENSIONS AND PARAMETERS

Size/VEL	H	A	B	F	G	E	R	T1	d	F <sub>p</sub>	y <sub>max</sub>	m
-	mm	mm	mm	mm	mm	mm	mm	mm	mm	kN	mm	kg
1	113	270	130	170	110	78	26	6	10	8,0	85	2,1
2	130	310	170	190	147	93	31	8	10	12,6	85	13,9
3	159	330	215	190	190	108	36	10	12	18,6	85	28,4
4	212	380	270	230	245	147	49	15	12	31,7	85	58,9
5	245	410	305	250	277	180	60	15	14	81,0	85	78,8

Other dimensions as the P42 type

y<sub>max</sub> – maximum movement in lateral direction

F<sub>p</sub> – permissible load in vertical direction

### MATERIAL DESIGN

Steel S235JR with zinc coating Z275



# 9

# GENERAL TECHNICAL INFORMATION

## 9.1. PIPE SUPPORTS

The term “pipe support” refers to all assemblies and mechanical elements, such as pipe shoes or hangers, that connect the pipe and/or other parts of piping system to supporting or foundation structure.

The main function of a pipe support is to uphold a piping system at desired location:

- By transferring the weight of the piping to supporting structures (or floors);
- By transferring internal and external forces from piping to supporting structures;
- By limiting operating or assembly displacements and rotations of the piping, caused by internal or external forces or thermal expansion;
- By controlling the distribution of forces related to pipe displacement.

Also, other secondary but just as important functions of a pipe support include the following:

- Possibility of single or multiple adjustments of the pipe position or support reaction forces;
- Protection of pipe surface against damage, abrasion and related corrosion;
- Protection of piping insulation;
- Protection of the against the effects of dynamic and seismic shocks;
- Reduction of the frictional forces that would result from the use of common supports;
- Reduction of heat transfer from the pipe to the environment and vice versa.

## 9.2. FIELD OF APPLICATION

In terms of application parameters, the catalogue covers the following pipe supports for:

- Standardized assemblies and components that are verified by manufacturer’s technical experience;

- Piping of nominal size **DN from 15 mm to 800 mm**;
- Piping made of following materials: carbon steel, Cr-Mo steel, austenitic steel, polyolefins (PE, PP), fiberglass (GRP);
- Steel pipes with the ratio  $e/D_e \Rightarrow 0.006$  of the wall thickness “e” and diameter “De”;
- **Piping working temperature from -180 °C to +700 °C**;
- Ambient temperature from -50 °C to +200 °C;
- Loads up to 500 kN;
- Static, cyclic, dynamic (shock), seismic and other loads.

In terms of production standards, the catalogue covers pipe supports for:

- All piping designed and constructed in accordance with the European Pressure Equipment Directive (PED);
- Metallic industrial piping designed according to EN 13480, all design classes;
- Boiler piping and headers designed according to EN 12952;
- Piping designed according to EN 1993-4-3 regulations for steel structures;
- Piping designed in accordance with European regulations for gases and long-distance liquid or heat pipelines;
- Piping for power, chemical and petrochemical industries designed according to ASME B31.1 and B31.3, with further reference to MSS SP-58 and MSS SP-69;
- Boiler piping according to ASME BVPC Section I;
- Process piping according to ПБ 03-585-03;
- Steam and hot water piping according to ПБ 03-573-03;
- Boiler piping, according to ПБ 10-574-03;
- Non-metallic piping, such as polypropylene (PP), polyethylene (PE) and fiberglass reinforced plastic (GRP).

In terms of industrial use the catalogue covers pipe supports for:

- Power industry (conventional and nuclear power plants, cogeneration plants, heating plants, etc.);
- Chemical and petrochemical industries;
- Transport or supply of fluids and heat, including long-distance pipelines;
- Building services.

## 9.3. TERMS AND DEFINITIONS

### 9.3.1. TERMS

**Pipe supports** - A general term used to describe a series of assembled components which make up a pipe hanger, pipe support, restraint, anchor, guide, etc. It includes all elements and components that connect a pipe to supporting structure, as defined by boundaries (see below). They are also called pipe support assemblies.

**Boundaries** - boundaries between pipe support and other structures, shown in Figure 9.3-1.

Fig. 9.3-1 – Boundaries

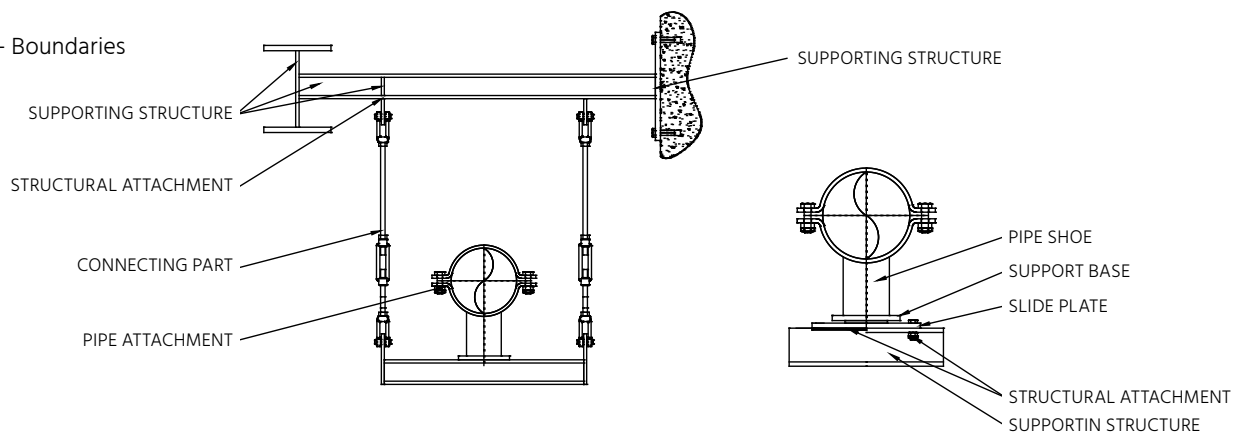

**Supporting structure** – in various standards also called auxiliary, steel or main structure. It is fixed and has no other functional relation to pipe supports than a load-bearing one (it is not used to control friction, displacement, elasticity, etc.). The supporting structure is part of building and as such is constructed according to civil or structural standards. Its boundaries are defined in 9.3.1.

**Support component** – a part of a pipe support assembly, e.g. clamp, hanger rod, pipe shoe, spring, etc.

**Structural attachment** – forms the boundary between the pipe support and the supporting structure. It can be a weld, bolt joint, anchor bolt, anchor plate, etc. The design of the attachment is the responsibility of the supplier of pipe supports or supplier of the piping system, except for anchor plates embedded or anchored to concrete, which are considered to be part of the structure (due to specific properties).

**Pipe attachment** – forms the boundary between the support and the pipe wall. It can be of welded or clamped design.

**Support (or resting/sliding support)** – A device by which piping is carried from beneath and is used to carry the piping weight in compression. It usually consists of one or more pipe shoes, attached to pipe with a weld or a clamp, that carry the piping weight to a slide plate or directly to structure. In most cases the support consists of one pipe shoe. Supports with more pipe shoes usually form a guide or. The pipe shoe may also be equipped with a lift-off restraint – in this case it is also capable of transferring tension forces. However, permissible in tension loads are different to compression loads.

**Hanger** – A device which is suspended from a structure and is used to carry the piping load in tension (without friction). It consists of a pipe attachment and a structural attachment connected with a rod. In order to avoid rod bending or torsion stresses, the rod assembly must include a link that allows rotation of rod all directions.

**Rigid strut** – A device used to carry the piping load both in tension and compression. It can be used as a vibration limiter or a restraint.

**Connecting element** – all parts of hanger rods. Does not include bolting material used for attaching slide plates or anchor plates.

**Support base** – the bottom component of a pipe support, which performs relative movement with respect to the slide plate or supporting structure during piping movement.

**Slide plate** – A flat plate, fixed to support structure, whose surface has been prepared in a manner which will facilitate a sliding motion

**Guide** – A device used to permit pipe movement in axial direction while restraining movement in lateral direction. It can consist of one or multiple pipe shoes. A gap is specified between the pipe shoes and supporting structure or stops welded to slide plate.

**Snubber** – Usually a hydraulic (but can also be mechanical, or spring) device used for the control of shock and sway in piping systems, while allowing for normal thermal expansion.

**Axial direction** – direction of pipe axis.

**Lateral direction** – direction perpendicular to pipe axis.

**Vertical direction** – vertical direction perpendicular to pipe axis.

**Definitions** – in order to ensure various effects of pipe restraints, i.e. limiting movements and transfer of forces in a specific way, standard support types are specified, as defined in the following

text. The definitions may vary from EN 13480-3.

**Characteristic load value  $F_k$**  – load values specified piping manufacturer's engineer, obtained from piping stress and flexibility analysis and categorized according to load categories, see 9.6.3.

**Design load  $F_d$**  – The combination of operating and other loads as defined by job specification. Load values for support design, obtained from characteristic values  $F_k$ , usually increased by a load reliability factor, according to 9.6.3. The design loads are compared with permissible load values.

**Piping design temperature  $t_d$**  – maximum operating temperature of the piping or other temperature specified by piping engineer. Permissible load  $F_p$  – load acting on a support element or assembly obtained by calculation during the design of supports elements.

**Support design temperature  $t_c$**  – temperature of support element obtained piping design temperature by using the temperature corrections, according to 9.6.4.

**Cold load  $F_c$**  – Support load at ambient temperature (usually equal to the installation reference temperature, not the minimum design temperature).

**Spring pre-set force  $F_s$**  – is worked out from the value of cold load, or any other value specified by piping stress and flexibility analysis, increased by the weight of pipe attachment elements.

**Rod hanger (or rigid hanger)** – An adjustable vertical assembly consisting of a structural attachment, hanger rod (with or without intermediate components), and pipe attachments. It is designed to withstand tension loads only. For piping of DN80 and larger the hanger assembly shall contain length adjusting elements for adjustment during assembly or operation. The hanger assembly shall allow angular deflection of rods from vertical axis of +/- 4°. There are single rod hangers for horizontal piping or double rod hangers for both horizontal and vertical piping.

**(Variable) Spring hanger** – A pipe hanger that uses a spring or springs (with a linear characteristic) to permit vertical movement in a piping system. The spring hanger assembly shall contain a length adjusting elements for adjustment during assembly or operation. The hanger assembly shall allow angular deflection of rods from vertical axis of +/- 4°. There are single rod spring hangers for horizontal piping or double rod spring hangers for both horizontal and vertical piping.

**Constant effort hanger** – A mechanical and spring coil device which produces a relatively constant supporting effect, while permitting vertical pipe movement. Other features and versions are the same as for the spring hanger.

**Sliding support** – A device consisting of a pipe shoe placed under a horizontal pipe or two brackets for vertical piping, to accommodate horizontal pipe movement.

**(Variable) Spring support** – A device used for transfer of vertical loads and allowing vertical movement. It consists of a pipe shoe placed under a horizontal pipe (or two brackets for pipes) and a spring block (with linear characteristics).

**Constant effort support** – A device used for transfer of vertical loads and allowing vertical movement. It consists of a pipe shoe placed under a horizontal pipe (or two brackets for pipes) and a constant effort spring block (with constant characteristics).

**Anchor** – A rigid device used to prevent essentially all pipe rotation and displacement at the point of application.

**Support with lift-off restraint** – a sliding support that prevents movement in both positive and negative vertical direction. It allows the pipe to move in horizontal direction.

**Sliding support with guide** – a sliding support with elements limiting lateral movement – usually a pipe shoe with stops welded to support structure or a slide plate.

**Sliding support with guide and lift-off restraint** – a guided pipe shoe with elements limiting vertical direction in the upward direction.

**Axial stop** – device used to limit pipe movement in a axial pipe direction with or without a gap.

**Sliding support with axial stop** – a sliding support with elements limiting axial movement – usually a pipe shoe with stops welded to support structure or a slide plate.

**Stop** – A device used to limit pipe movement in in all directions but allows pipe rotation – i. e. moment-free anchor.

## 9.4. TYPES OF PIPE SUPPORT ASSEMBLIES – HANGERS AND SUPPORTS

### 9.4.1. GENERAL REQUIREMENTS AND TYPES OF PIPE RESTRAINTS

The piping manufacturer is responsible for selecting the type and design of restraints, order specifications and design and construction of auxiliary structures. The manufacturer's piping engineer shall provide the supplier of pipe supports all data of loads, required movement limitations and required connection

dimensions, as specified in the piping design standards (e.g. EN13480-3, ASME B31.1. etc). The support manufacturer will design the pipe supports based on required restraint function. Basic pipe support types, according to their required function, are listed in Table 9.4-1.

Table 9.4-1 – Types of pipe restraints

Abbreviation	Name	Description, type of restraint
HR	Rod hanger	Transfer of vertical load and prevention of vertical downwards movement by means of a rigid rod. Single- or double-rod design for both vertical and horizontal piping. It allows horizontal movement.
HS	Spring hanger	Transfer of vertical load by means of a rod and a spring, with linear or constant characteristics. Single- or double-rod design for both vertical and horizontal piping. It allows horizontal and vertical movement.
VS, VV, SB	Spring support	Transfer of vertical load, by means of a pipe shoe under horizontal pipes or two brackets for vertical pipes, and a spring block with linear or constant characteristics. It allows horizontal and vertical movement.
SS, SV	Sliding support	Transfer of vertical loads and prevention of vertical downward movement by means of a pipe shoe under horizontal pipe or two brackets on vertical piping. It allows horizontal movement. Frictional forces act in direction of movement.
SL, SG, GV	Sliding support with guide	Pipe shoe with limited lateral movement and a specified gap of min. +/-2 mm. Friction forces act in the direction of pipe axis and in the direction of pipe movement.
SA	Sliding support with axial stop	Sliding support with elements limiting axial movement with specified gap of min. +/-2 mm. Friction forces act in the in the direction of pipe movement.
G2, G4	Guide	A device used to permit pipe movement in axial direction while restraining movement in lateral direction with a specified gap of min. +/-2 mm. Friction forces act in axial pipe direction.
SR	Stop	Limits movement in all directions, transfer of all forces (no moments). A moment-free anchor.
FP, FV	Anchor	Limits movement and rotation in all directions, transfer of all force and moment components.
RS	Lateral stop	Limits movement in one direction perpendicular to pipe axis, without a gap. Transfer of forces in both positive and negative lateral direction. It usually has the form of a rigid strut (without friction).
AS	Axial stop	Limits movement in axial pipe direction, without a gap, transfer of forces in both positive and negative axial pipe direction. It usually has the form of rigid struts (without friction).
DS	Snubber	Limits movement in one direction, if the speed of movement exceeds the threshold speed. Thermal expansion is not limited (movement below the threshold speed is not limited).

The boundaries dividing the pipe support element or assembly from surrounding equipment or structures, is determined, according to EN 13480-3, clause 13.1.4.

**9.4.2. SELECTION OF HANGERS, SUPPORTS AND PIPE GUIDES FROM THE PIPE SUPPORT CATALOGUE**

The pipe support type is selected based on required function of the restraint and in accordance with Figures 9.4-3 (supports) and 9.4-4 (hangers). Pipe support materials and load group are selected by the pipe support supplier taking into consideration load

parameters and design temperature. These standard assemblies are proven to be reliable and they consist of standard catalogue components. The pipe support assemblies meet the requirements of EN 13480-3 and MSS-SP 69.

**9.4.3. SUPPORT ASSEMBLIES AND THEIR STRUCTURAL AND PIPE ATTACHMENTS**

PIPE ATTACHMENT ELEMENTS

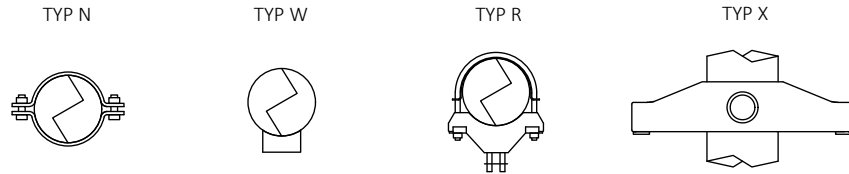

SUPPORTS, GUIDES

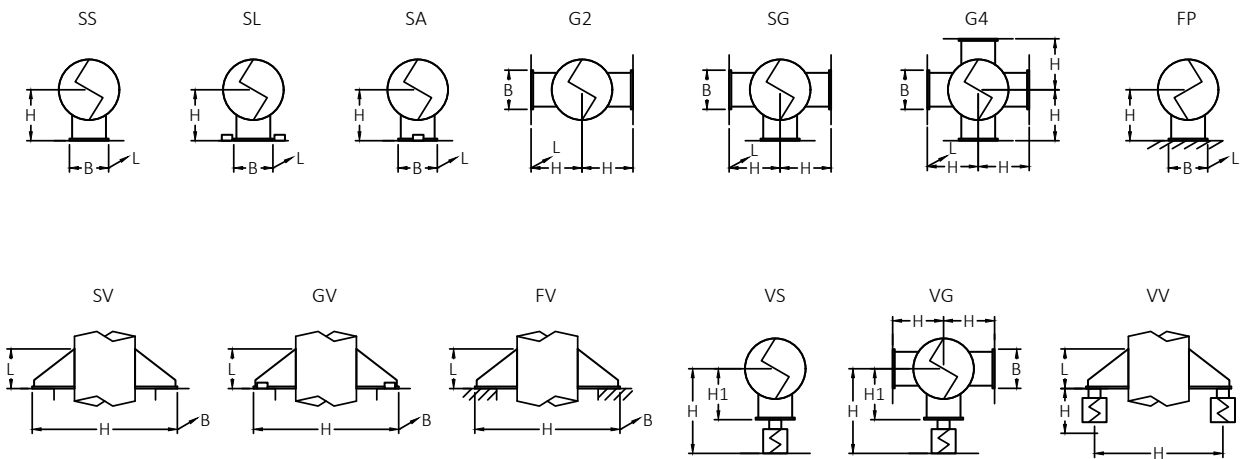

ANGULATED SUPPORTS AND STRUTS

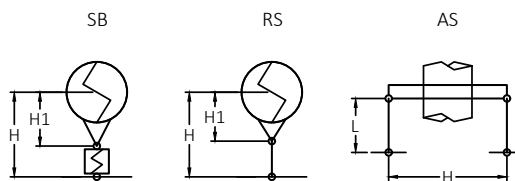

STRUCTURAL ATTACHMENT ELEMENTS

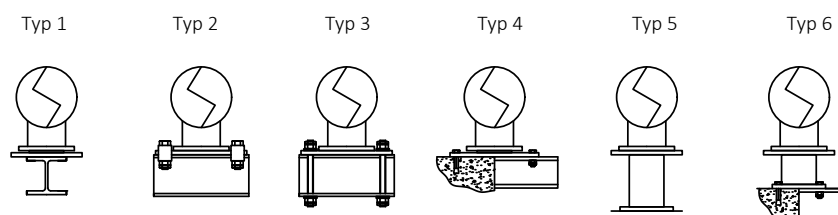

9.4.4. HANGER ASSEMBLIES AND THEIR STRUCTURAL AND PIPE ATTACHMENTS

STRUCTURAL ATTACHMENT ELEMENTS

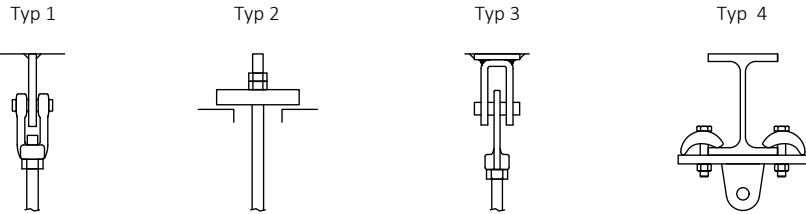

ROD HANGERS

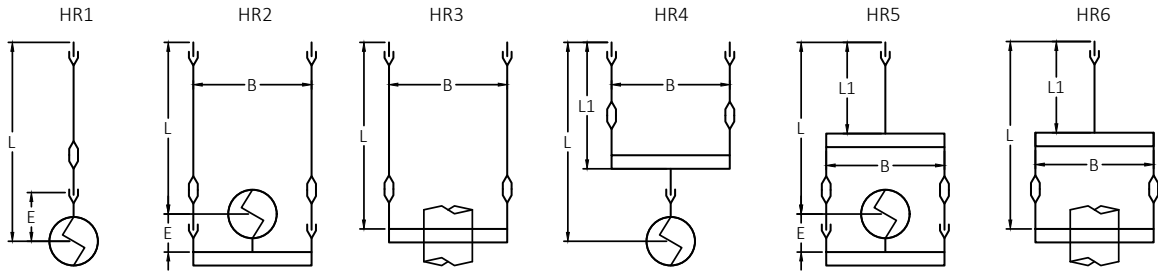

SPRING HANGERS

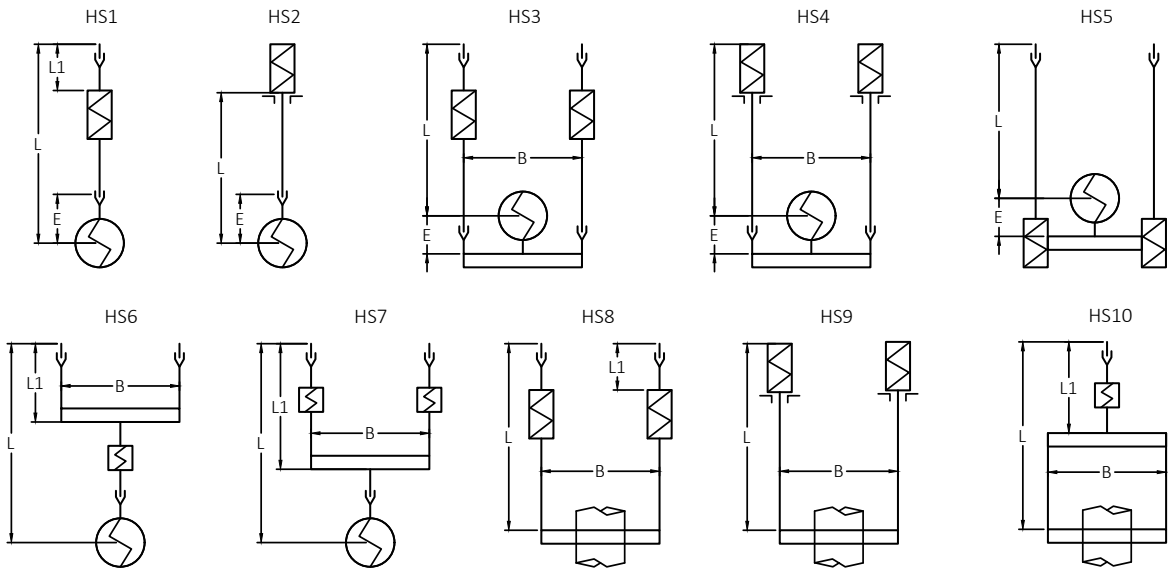

PIPE ATTACHMENT ELEMENTS

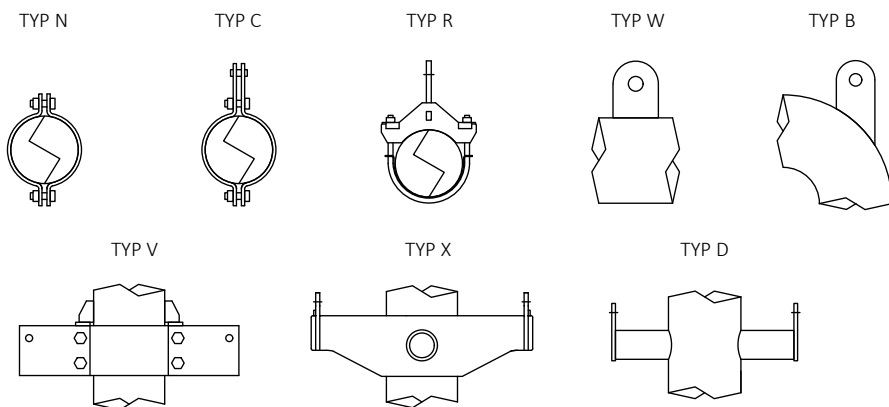

### 9.4.5. TYPE DESIGNATION OF ASSEMBLIES

Standardized catalogue assemblies of piping supports can be identified by a code that defines the type and design of the

restraint, and contains basic dimensional data, nominal load data and data on the material of the part that is in contact with the pipe.

Table 4-3

ST	T	P/S	DNK	M	L*	sN**	H/L	L1/B
XX	X	XX	XXX	X	X	X	XXX(X)	XXX(X)
Assembly type code	Assembly configuration code	Pipe connection element / structural attachment	Pipe diameter code	Material group code	Load group code / spring size	Nominal displacement code	Additional dimension 1	Additional dimension 2

\* not used for rigid supports

\*\* only used for spring supports/hangers, not used for other elements

#### Examples of designation:

HR1-R1-200-33-1500-240	Single-rod hanger with a clamp with U-bolt for horizontal piping, attached to structure by a weld-on eye, nominal pipe diameter of DN200, material group 3, load group 3, total assembly length 1 500 mm, pipe attachment height 240 mm.
HS3-N2-159-142-2000-600	Double-rod spring hanger for horizontal piping with clamped pipe shoe, attached to the structure with a spherical washer, pipe of outer diameter of 159 mm pipe, material group 1 (see 9.4.7), spring size 4, spring travel range of 100 mm, overall assembly length 2 000 mm, rod spacing 600 mm.
SS-W5-080-1-320-170	Pipe shoe for horizontal pipe with welding support, attached to the structure by the support pipe, DN 50 mm pipe, material group 1, overall assembly height 320 mm, support height 170 mm.

#### 9.4.6. PIPE DIAMETERS AND THEIR DESIGNATION CODE NUMBERS

Standard pipe supports and pipe attachment elements are designed for outer pipe diameters according to EN 10220 (EN 10216-2 to -5, EN 10217-1 to -7) and EN ISO 1127 (selection).

The pipe outer diameter is identified by the DNK code, according to Table 9.4-6, which determines the pipe outer diameter OD to corresponding nominal diameter DN.

Table 9.4-4

DN	OD (mm)	DNK code
10	14	010
	18	018
15	21,3	015
20	26,9	020
25	31,8	025
	33,7	025
32	38	038
	42,4	032
40	48,3	040
50	57	057
	60,3	050
65	73	073
	76,1	065
80	88,9	080
100	108	108
	114,3	100
125	127	127
	133	133
	139,7	125
	141,3	141
150	159	159
175	168,3	150
	193,7	175
200	219,1	200
225	244,5	225
250	273	250
300	323,9	300
350	355,6	350
	377	377
400	406,4	400
	426	426
450	457	450
500	508	500
	530	530
550	559	550
600	610	600
	630	630
650	660	650
700	711	700
	720	720
750	762	750
800	813	800
	820	820

**Outer diameter tolerance** – pipe clamps are designed for outer diameter tolerances according to EN 10216 or ASME B36.10, for pipes calibrated to outer diameter.

**Pipe clamps for pipe calibrated to the inner diameter** – if pipe clamps are required for this type of pipes then tolerances of pipe diameter and wall thickness shall be specified in the order. The pipe support manufacturer will design the clamps so that the conditions of usability are fulfilled.



### 9.4.7. MATERIAL GROUPS

Material group codes are listed in the table below, the materials have been grouped based on material composition and design temperatures.

Table 9.4-5

Material group	Type of steel according to composition	Temperature of use °C	Group – CEN ISO TR/20172
1	Structural carbon steel	Up to 350	1.1, 1.2
2	Carbon steels C-1/2Mo	Up to 480	1.1
3	Ferritic-pearlitic steels 21/4Cr-1Mo	up to 600	5.2
4	Austenitic steels 18Cr-8Ni	Up to 400	8.1
5	Austenitic steels 16Cr-12Ni-2Mo(Ti)	Up to 550	8.1
6	Austenitic steels 18Cr-10Ni	Up to 650	8.1
7	Fine-grained carbon and Mn steels	Less than -20	1.1
0	Hot-dip galvanized steels	Up to 150	1.1

### 9.4.8. LOAD GROUS

The load groups of hanger rods express unified load-bearing capacities of rod components and unified connection dimensions that apply also to other product groups (pipe connection

elements, structural attachment elements, trapezes.) The load group is a sequence number, which is related to rod thread diameter and pin diameter. The pin diameter is compatible for all components in a load group.

Table 9.4-6

Load group	Rod thread (mm)	Pin diameter (mm)	$F_p$ (kN)	Spring size	$F_N$ of spring (kN)
0	M10	10	1,0	M	0,375
				L	0,75
1	M12	12	7,6	1	1,5
				2	3,0
2	M16	16	14,9	3	6,0
3	M20	20	23,7	4	11
4	M24	24	32,0	5	20
5	M30	33	52,3	6	35
6	M36	40	68,2	7	57
7	M42	45	93,6	8	80
8	M48	50	125	9	100
9	M56x4	60	176	H	-
H	M64x4	70	200	X	-
X	M72x4	80	328	S	-

$F_p$  Permissible load of the rod assembly  
 $F_N$  Nominal spring size

Code designation of spring nominal working travel  $s_N$ :

Table 9.4-7

Code $s_N$	Nominal spring travel (mm)
1	50
2	100
3	200
4	300
5	450

## 9.5. PIPE SUPPORT CLASSIFICATION

### 9.5.1. CLASSIFICATION ACCORDING TO EN 13480-3

The support is classified into classes, depending on the category of the piping on which the supports are installed (according to EN 13480-1, chapter 4):

Table 9.5-1

Piping category	Support class
III	S3
II	S2
I a 0	S1

Requirements for material quality, manufacturing, testing and documentation are specified for each support class – according to EN 13480-3 Annex N, Table N-1.

The support class must always be specified by the client in the order.

### 9.5.2. CLASSIFICATION ACCORDING TO ASME B31.1, ASME B31.3 AND MSS SP-58

The standard MSS SP-58 classifies the pipe supports into classes according to pipe temperature. The support classes then define applicable components and requirements for design, material and manufacturing.

#### Classes according to MSS SP-58, Annex A:

1. Host Systems  
Class A-1 (49 to 232 °C), A-2 (233 to 399 °C), A-3 (over 399 °C);
2. Ambient Systems  
Class B (16 to 48 °C);
3. Cold Systems  
Class C-1 (1 to 15 °C), C-2 (-28 to 0 °C), C-3 (-39 to -29 °C), C-4 (below -40 °C).

### 9.5.3. CLASSIFICATION ACCORDING TO RUSSIAN REGULATIONS

Pipe supports for maximum permissible piping pressures up to 10 MPa and maximum permissible temperatures above 450 °C are designed and manufactured in accordance with ГОСТ 22130-76.

## 9.6. DESIGN RULES

### 9.6.1. SELECTION OF SUPPORT TYPE

The piping design engineer should follow these recommendations during the process of selection of pipe support types. The recommendations are based on years of design and maintenance experience with piping systems in power stations, refineries, etc. The engineer should consider:

- Required movement limitations;
- Location piping system – i.e. if a hanger or a support is required;

- Horizontal pipe movements – i.e. if a hanger or a support is required – permissible angular deviation of hanger rods from vertical axis is 4°;
- Effects of friction – under some operating conditions it may be difficult to guarantee a support friction coefficient of 0.3. It cannot be always guaranteed that supports with special treatment of sliding surface will keep their assumed friction properties in the long term;
- Hangers allow (easier) adjustment even during operation and do not require treatment of sliding surfaces;
- Pipe shoe support should be used where the distance between the pipe surface and the steel structure or floor under the pipe is up to a max. 2 x DN; if the distance is greater, the supports should be placed on posts;
- Piping on hangers – requirements for headroom clearance shall be observed – the distance from the ground to the bottom of the pipe shall be at least 2.1 m (the distance shall include insulation and expected thermal expansion in the downward direction);
- The distance between the insulation surface and the support base should preferably be at least 30 to 50 mm;
- Hanger clamps are easier to insulate than pipe shoes;
- Springs or PTFE sliding surfaces must always be outside the insulation, with a gap of at least 50 mm;
- Use of spring or constant supports should be avoided for support locations with large horizontal movements;
- Vertical piping should be preferably supported on hangers – the reason being is the possibility of multiple re-adjustments
- Hangers shall be of sufficient length, so that the rod deflection from the vertical axis does not exceed +/- 4°, measured on the effective rod length. (i.e. the distance from the clamp connection pin, to the structure connection pin)
- It is preferable to use spring hangers with the spring located in the rod chain (e.g. see picture in chapter 9.4.4 – type HS1, HS3) rather than those with the spring sitting on a beam or on a support trapeze (e.g. type HS2, HS4 or HS5)
- Single-rod hangers should be preferred, double-rod hangers should only be used when there is insufficient space for the minimum required length, or the rod collides with the piping above the point of support;
- The springs should be positioned in such a way that they are visible from the ground or from service platforms. However, the springs should preferably be positioned as close as possible to the top attachment pin (because of rod swinging);
- The use of hangers on piping with dual-phase flow lines should be limited;
- The length of hanger rods should be limited in consideration of hanger swinging and seismicity;
- The first pipe support closest to rotating equipment, heat exchangers or vessels should allow height-adjustment during operation;
- Rigid struts shall be used instead of hangers for suspension of piping where it is required that vertical upward movement is restrained;
- In order to reduce piping vibration, rigid struts shall be used rather than guides or guided pipe shoes;
- If there is a requirement for guides or stops without friction or with minimum possible gaps, rigid struts shall be used.

### 9.6.2. GENERAL PRINCIPLES OF SUPPORT DESIGN

The pipe support systems must be designed so that the requirements of the design of piping system are met. All main design characteristics of assemblies and individual elements shall be described in the support data sheet.

**9.6.3. DESIGN LOAD  $F_d$**

The design load is specified based on loads provided by the piping engineer so that this value can be compared with the permissible load of a support component or assembly.

**a. Load categorization**

Depending on the nature of the action (constant/variable, occasional) and the nature of the reaction (with or without possible effect on the structure), the loads are categorized as follows:

Table 9.6-3

G Permanent loads	Permanent load – all assumed loads and effects that have a long-term effect. The main examples include: <ul style="list-style-type: none"> <li>• Dead weight of piping, fluid and other components,</li> <li>• Loads from restrained thermal expansion,</li> <li>• Forces from anchor movement,</li> <li>• Forces from cold-springing of the piping,</li> <li>• Forces from axial (un-tied) flexible joints,</li> <li>• Frictional forces from pipe movement,</li> <li>• Forces from tightening of bolts,</li> <li>• Deformation effect when the pipe diameter changes due to pressure or creep.</li> </ul>
Q Occasional loads	Expected short-term load. The main occasional load types include: <ul style="list-style-type: none"> <li>• Wind load,</li> <li>• Dynamic forces during valve opening,</li> <li>• Earthquake,</li> <li>• Pressure test,</li> <li>• Snow load.</li> </ul>
A Accident loads	Expected one-off load of an emergency nature, the action of which may affect the condition of the structure. The main examples include: <ul style="list-style-type: none"> <li>• Exceptional earthquake,</li> <li>• Explosion, impact,</li> <li>• Failure of a support.</li> </ul>

The categorization provided in Tab. 9.6.3 is specified according to EN 1990 and EN13480-3. When a different standard or regulation is required for evaluation, categorization according to standard specified in the order (ASME, VGB, GOST, PNAEG, etc.) shall be followed.

All loads listed in Table 9.6.3 shall be considered primary mechanical external loads for all components of the support assembly, including parts welded to the piping.

**b. Design value of an action  $F_d$**

It is the load value that is compared with the permissible load value (does not apply when establishing the required load of spring cannisters). It is determined, according to formula /1/ and the following methodology, which is derived from methodology, according to EN 1990.

$$F_d = \gamma_F \times F_{rep}, \text{ where} \quad /1/$$

$F_{rep}$  is a representative value of an action, usually  $F_{rep} = F_k$   
 $\gamma_F$  is the partial load safety factor

Load combination	Partial load safety factor $\gamma_F$
G Permanent load	$\gamma_{FG} = 1,0$ for pipes with wall thickness tolerance up to +/- 20% $\gamma_{FG} = 1,1$ for pipes with wall thickness tolerance up to -0/+ 20% $\gamma_{FG} = 1,15$ for pipes with wall thickness tolerance up to -0/+ 25%
Q Variable load	$\gamma_{FQ} = 1,0$ for pressure test and wind load $\gamma_{FQ} = 1,2$ for dynamic load

The factor  $\gamma_F$  expresses possible adverse variations of values of an action from characteristic values, such as:

- The piping stress and flexibility analysis is performed for nominal pipe wall thickness, but the wall thickness has a positive tolerance (which also increases the weight);
- Spring hangers and supports are required to have the possibility of additional load adjustment of 15% of the pre-set load, which can be performed during operation.

**Note:** the coefficient  $\gamma_F$  should be chosen by the piping engineer, as the support manufacturer may not be informed of tolerances of the pipes used.

**9.6.4. DESIGN TEMPERATURE  $T_d$**

The design temperature for individual parts of pipe supports is specified considering the pipe design temperature  $t_p$ , according to the following procedure and Figure 9.6.4 for insulated piping. The piping design temperature  $t_p$  is not the design or calculation temperature in terms of the pipe support design but it is specified as the highest mean pipe wall temperature.

**a. General parts**

The design temperature of all parts should be at least  $t_d = 80^\circ\text{C}$ . Slide plates and their bolting elements are considered to be general parts, which also applies to insulated piping. The minimum design metal temperature MDMT equals to the minimum ambient temperature.

**b. Parts in contact with uninsulated piping**

$$T_d = \max \{0.5 t_p; 80^\circ\text{C}\}; \quad /2/$$

**For connected pins or bolts and nuts of clamps:**

$$T_d = \max \{0.33 \times t_p; 80^\circ\text{C}\} \quad /3/$$

**c. Parts located inside insulation**

For parts in direct contact with piping:  
 $T_d = t_p \quad /4/$

For parts not in direct contact with the piping:  
 $T_d = t_p - 20^\circ\text{C} \quad /5/$

For screws and nuts:  
 $T_d = t_p - 30^\circ\text{C} \quad /6/$

**d. Parts close to insulation**

$$T_d = \max \{0.5 \times t_p; 80^\circ\text{C}\}, \quad /7/$$

For connected pins, parts, bolts and nuts:  
 $T_d = \max \{0.33 \times t_p; 80^\circ\text{C}\} \quad /8/$

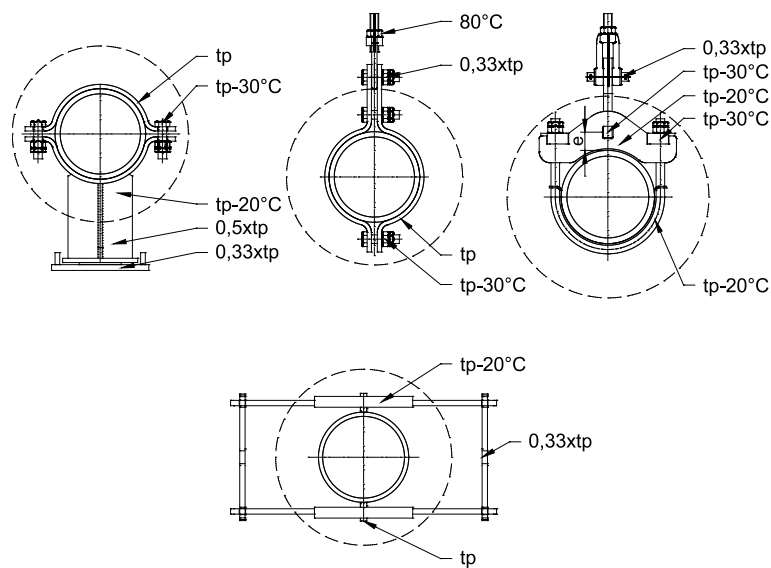
Fig. 9.6.4 Temperature  $t_d$  of components

### 9.6.5. PERMISSIBLE LOAD $F_p$

The permissible load of a support component is the value of the lowest load-bearing capacity of the component, determined for the given design temperature and material. It is specified for reference temperature of 80 °C. For higher design temperatures, the value obtained this way is then multiplied by the temperature correction factor  $k_{tm}$ .

### 9.6.6. CYCLIC LOAD

Components of pipe supports are always exposed to cyclic load that occurs due to the transition of the piping from cold to operating condition, due to temperature fluctuations during operation, pipe vibrations and other cyclic. Therefore, the following load combinations must be considered in the design process:

#### a. Fixed support assemblies (hangers, supports, etc.)

Load change in the range from 0 to  $F_d$  for 2 000 cycles (number of possible equipment cold starts), for the mean temperature of cycle  $t^* = 0,5 \times t_d$

Load change in the range of  $0,25 \times F_d$  pro 8 000 cycles (number of possible equipment cold starts), for the mean temperature of cycle  $t^* = t_d$

Load change in the range of  $0,1 \times F_d$  pro 1E 6 cycles (number of possible cycles from vibrations and other fluctuations), for the mean temperature of cycle  $t^* = t_d$

#### b. Spring support assemblies (hangers, supports, etc.)

Load change in the range from  $0,5 \times F_N$  for 2 000 cycles (number of possible equipment cold starts), for the mean cycle temperature  $t^* = 0,5 \times t_d$

Load change in the range of  $0,25 \times F_d$  pro 8 000 cycles (number of possible equipment cold starts), for the mean cycle temperature  $t^* = t_d$

Load change in the range of  $0,1 \times F_d$  pro 1E 6 cycles (number of possible cycles from vibrations and other fluctuations), for the mean cycle temperature  $t^* = t_d$

#### c. Rigid strut and snubber assemblies

Load (amplitude)	Number of cycles
$1,5 \times F_N (F_d)$	25
$1,0 \times F_N (F_d)$	3 300
$0,5 \times F_N (F_d)$	47 000
$0,1 \times F_N (F_d)$	330 000

For mean temperature of cycle  $t^* = t_d$

## 9.7. GENERAL DESIGN REQUIREMENTS

### 9.7.1. SUPPORTS

Sliding supports are designed so that contamination of sliding surfaces during normal operation is prevented. This means that the support base should overlap the sliding surface under all operating conditions.

The sliding surfaces shall be of sufficient size to allow displacement reserve of 25 mm in all directions under all operating conditions. This applies especially for supports with PTFE sliding surfaces.

Sliding supports shall be designed so that it is ensured that the calculated static frictional forces are not exceeded, even after long-term operation. When used outdoors or in a dusty environment, measures must be taken to protect the sliding surfaces against contamination with dirt. The position of sliding surfaces must be properly secured. Special sliding materials (slide paints, PTFE) may only be used, if their properties cannot be compromised by heat conduction, radiation, contamination or other operating influences.

Sliding supports are designed for horizontal forces with a friction coefficient of 0.3 (corroded steel-steel contact) in all directions perpendicular to the action of main forces.

For pipe shoes, designed to be used as guiding elements, the permissible loads in all directions and their combinations must be specified in all directions and their combinations.

Clamped pipe shoes shall be designed and sized, so that the clamp and the pipe do not slip against each other when the pipe shoe or is loaded laterally – support tilting shall be avoided.

Guide assemblies and guided pipe shoes shall have a sufficient gap for the operating condition. Unless stated otherwise in the specification (gap for different thermal expansion), a gap of  $\pm 2$  mm is normally sufficient.

Clamp supports and guides for vertical piping for  $DN > (200-300)$  must be equipped with shear lugs against movement in axial pipe direction.

Axial stops and anchors shall be equipped, where appropriate, with shear lugs on both sides to prevent the pipe from slipping in the axial pipe direction.

### 9.7.2. HANGERS

The hangers are preferably mounted vertically during assembly. The deflection of hanger rods under operating conditions shall not exceed angular deflection of  $4^\circ$  from the vertical axis.

The spring units should preferably be position so that they are accessible for inspection of pre-setting after installation.

Rod hangers shall be designed so that they can move freely between two rod joints. Permissible design of rod joints is: spherical washer in a spherical hole, pin-eye, ball bushing joint. The pin-eye joint must have a gap of a min. of 2 mm.

### 9.7.3. ROD HANGERS

Rigid hangers for piping of  $DN \geq 80$  shall be provided with a tensioning element for proper adjustment or re-adjustment of the piping during operation.

Extension of hanger rods must be provided with threaded elements; welding of rods is not permitted.

Rod hangers for the vertical piping shall be designed so that one rod is capable of carrying the entire load of the assembly unless a clamp, that allows its rotation in a direction perpendicular to the plane of the rod pair, is used.

Double-rod rigid hangers for horizontal piping shall be designed so that one rod is capable of carrying 2/3 of the total load of the assembly.

Double-rod rigid hangers for horizontal movements causing angular deflections of the rod from vertical direction of more than  $2.5^\circ$  shall be attached to the structure at one point (see chapter 9.4.4 – hanger type HR4, HR6).

### 9.7.4. SPRING HANGERS AND SUPPORTS

Spring blocks with linear characteristics (variable springs) are usually used to compensate movements up to 50 mm.

It is recommended to limit the load variation between hot and cold conditions to maximum 25 %, unless otherwise proven by the piping stress and flexibility analysis.

Travel reserve must be considered when selecting spring units. Required travel reserve for spring hangers/supports:

- For installation (cold condition) position – at least 5 mm to each extreme position;
- For operating position – 10 % of the maximum design travel  $s_H$  to each extreme position but not less than 5 mm;
- For position under cyclic load – no reserve is required;
- For position under an occasional load – even travel outside the working range can be achieved;
- Some project specifications require that there is a possibility of additional adjustment of the pre-set load by 10% (which results in the same difference in force  $F_H$ ).

The load variation between the actual and the theoretical spring load shall not exceed 5 % in the whole travel range of the springs – this applies for both tension and compression spring load. The spring supports are designed to transfer lateral loads of  $0.3 \times F_N$ .

The spring blocks are shop-set for a cold load and locked against movement in both directions. The locking device is secured in place so that it does not fall out during handling.

When secured with the locking device the spring hangers and spring supports can withstand a vertical load of  $2 \times F_N$  without permanent deformation.

The spring units are provided with a name plate that contains the following information:

- Support reference number;
- Spring type (spring unit type);
- Size (nominal load);
- Nominal travel;
- Set load;
- Set pre-stressing;
- Position under operating condition (usually nominal);
- Manufacturer details

### 9.7.5. CONSTANT EFFORT HANGERS AND SUPPORTS

For the determination of  $F_{S_r}$ , the weight of all moving parts of the hanger/support shall be added to the load  $F_C$ , if the weight is greater than  $0,015 \times F_S$ .

Travel reserve must be taken into account when selecting constant effort spring units:

- For installation (cold condition) position – at least 25 mm to each extreme position;
- For operating position – 10% of the maximum design movement  $s_H$  to each extreme position but not less than 25 mm;
- For a position under cyclic load – no reserve is required;
- For a position under an occasional load – the position outside the working range can be achieved;

The load variation between the actual and the theoretical spring load shall not exceed 5 % in the whole travel range of the springs – this applies for both tension and compression spring load.

A requirement for additional adjustment of the pre-set load of 15 % shall be considered when selecting a constant effort spring unit without limiting the specified travel.

The load variation between the actual and the theoretical spring load shall not exceed 5 % in the whole travel range of the springs – this applies for both tension and compression spring load.

The constant spring supports are designed to transfer lateral loads of  $0.3 \times F_N$ .

The constant spring blocks are shop-set for required load and locked against movement in both directions. The locking device is secured in place so that it does not fall out during handling.

When secured with the locking device the constant spring blocks can withstand a vertical load of  $2.5 \times F_N$  without permanent deformation.

The constant spring units are provided with a name plate that contains the following information:

- Support reference number;
- Spring type (spring unit type);
- Size (nominal load);
- Nominal travel;
- Set load;
- Set pre-stressing;
- Position under operating condition (usually nominal);
- Manufacturer.

### 9.7.6 RIGID STRUTS

Rigid struts are equipped with maintenance-free ball bushing joints.

The length of adjustable rigid struts of all sizes and types can be adjusted by at least  $\pm 25$  mm.

The maximum permissible length of adjustment (by unthreading the joint heads) is marked so that minimum length of engaged thread is guaranteed.

The ball bushing joints allow an angular deflection of  $6^\circ$ .

The total free play of the rigid struts, including their connecting parts, is less than 0.5 mm when pins or fitting bolts up to a diameter of 33 mm are used; for larger pin diameters the free play shall be less than 1.5 % of the pin diameter.

All parts of the rigid strut assemblies are designed, according to their use and for cyclic loads, according to Table 9.7-6.

Table 9.7-6

Load amplitude $F_{Nn}$	Number of cycles
1,5 × FN	25
1,0 × FN	3 300
0,5 × FN	47 000
0,1 × FN	330 000

The dynamic pipe clamps for the rigid struts for cyclic loads are designed on the basis of allowable stress values that are calculated using creep rupture strength for 10 000 hours.

### 9.7.7 PIPE ATTACHMENTS

The attachments are designed in such a way that relative movement of the attachment relative to the pipe is avoided. Where necessary, positive engagement elements limiting this movement should be added, or the attachment should be modified to compensate for tolerances of pipe diameter.

The clamp type shall be selected, with regard to the tolerances of the pipes and clamps, so that the openings for the weld-on trunnions are axially aligned after assembly.

U-bolts with line contact shall not be used for supports of S2 and S3 classes or for temperatures  $t_d > 150^\circ\text{C}$ . For supports of S1 class, the U-bolts can be used for temperatures over  $100^\circ\text{C}$ , only for  $DN < 150$  and  $t_d < 300^\circ\text{C}$ , and only if there are no axial pipe loads.

To reduce the stress intensification on the pipe wall of piping with working temperatures above  $500^\circ\text{C}$  and for piping with OD greater than 168.3 mm, trunnions shall be welded to pipe with full penetration welds.

For non-insulated outdoor piping it is preferable to use weld-on lugs or welded pipe shoe supports.

Weld-on trunnions or shear lugs shall be designed so that the connected pipe clamps or their parts are attached outside the weld area. The free play between pipe clamps and pins shall not be too high.

### 9.7.8 STRUCTURAL ATTACHMENTS

Welds of plates thicker than 15 mm, shall be welded with partial penetration weld (i.e. the edges of the structural attachment are made with a bevel).

The rod pads and slide plates shall always be mechanically secured against relative movement on the supporting structure. Beam attachment brackets for attaching pipe hangers of  $DN > 50$  to beams without welding shall be designed in such a way that the transferred load is in the neutral axis of the beam.

The minimum size of anchor bolts is M12. If more than one anchor or fixing bolt is used to mount pipe hanger assembly of piping of  $DN > 50$ , M10 bolts may be used.

Slide plates shall be bolted to structure with bolts of minimum size of M8 provided that sufficient corrosion resistance of the bolts is provided.



### 9.7.9. ASSEMBLY WELD JOINTS

Assembly welds are most often used when hanger rods are attached to steel structure. Welds for all types of structural attachments shall be carried out as continuous. Single-layer welds are only permissible for welding of clevises and rod eyes of M10 and M12 sizes. For flat weld-on eyes, welding by method 111 is recommended. Method 135 may only be used in special justified cases.

Weld-on trunnions or shear lugs are welded on to the piping, according to documentation of the piping manufacturer. The piping manufacturer shall specify the pipe material in the technical specification for the supplier of pipe support, so that the two parts to be joined with a weld are made of mutually weldable materials and with the same or similar thermal expansion coefficient. The welds of shear lugs shall always be continuous. Welding of trunnions with full penetration one-sided fillet welds is permitted.

A welding plan of assembly welded joints shall be prepared by the piping supplier, including the specification of required welding methods and non-destructive testing.

The beam flanges, to which the welding eyes or clevises of hangers and rigid struts with a heavy load (approximately above 50 kN) are welded, shall be ultrasonically checked for lamination defects at the point of connection.

Welded joints shall be of quality class C, according to ISO 5817.

When welding surfaces of parts to be welded are treated with shop paint, which is not intended for welding by the manufacturer, it is necessary to grind the paint off at least 20 mm from the edge of the weld before welding.

Welding of threaded parts is not permitted, with the exception of carbon steel hanger rods with guaranteed weldability. The joint must always be subjected to a volumetric inspection of the weld and internal defects!

Welds of pipe shoes or shear lugs on piping, and weld-on eyes or clevises must be continuous.

Surface finish of the assembly joints must always be carried out, according to the project design specification (repair coat and topcoat).

### 9.7.10. SURFACE FINISH

The piping support components are supplied with a manufacturer-designed surface finish for specified corrosion aggressiveness of the outdoor environment and for required service life. Outdoor conditions and service life must be specified in the order specification.

Atmospheric corrosion aggressivity, according to EN ISO 12 944-2:

- C2 Low
- C3 Medium
- C4 High

Surface finish life:

- M Medium 5 to 15 years
- H High More than 15 years

Table 9.7-9

Part	Temperature	Environment	Surface finish	Coating thickness (mkm)
U-bolts, pipe clamps, pipe shoes, trapezes, auxiliary structures	Up to 120 °C	C3	Galvanizing	15
			Primer and topcoat	160
U-bolts, pipe clamps, pipe shoes, trapezes	Up to 120 °C	C4-C5	Hot dip galvanizing	85
			Primer and topcoat	240
U-bolts, pipe clamps, pipe shoes	140-500 °C	C3 *	Coating	100
U-bolts, pipe clamps, pipe shoes	Above 500 °C	C3 *	Coating	50
Structural attachment elements Weldable coating	Up to 80 °C	C3-C4	Coating	40
Spring units	Up to 80 °C	C3-C4	Galvanizing	15
Springs	Up to 80 °C	C3-C4	Powder coating	200
Threaded connecting elements	Up to 80 °C	C3	Galvanizing	15
Threaded connecting elements	Up to 80 °C	C4	Galvanizing	25
Threaded connecting elements	Up to 80 °C	C5	Hot dip galvanizing	50

#### Notes:

\* - components exposed to this temperature are assumed to be insulated and exposed to a temperature that does not allow effect of corrosive moisture.

**Sliding surfaces of supports** – for supports and guides, it is necessary to choose a suitable combination of surface finish of the sliding pair of support base – slide plate. If both sliding surfaces are painted with a topcoat, the friction coefficient of 0.15-0.3 is not guaranteed, and the surfaces may stick together and block the movement of the support or guide.

## 9.8. SPECIFICATIONS AND DOCUMENTATION

### 9.8.1. ORDER SPECIFICATION

#### 9.8.1.1. GENERAL INFORMATION

The order specification, prepared by the piping manufacturer's design engineer, shall include the following:

1. Project name;
2. Piping system identification;
3. Support reference number;
4. Required standard for design and delivery, piping category and support class;
5. Pipe outer diameter;
6. Pipe material;
7. Insulation thickness;
8. Type of support, or description of required function (movement limitation, etc.);
9. Pipe orientation – vertical, horizontal;
10. Type of structural attachment;
11. Type of pipe attachment – welding or clamped – (to be stated in a note);

12. Required characteristic dimensions – hanger length or support height, spacing of hanger rods, spacing guide elements, etc.
13. Maximum operating temperature of the fluid in the piping;
14. Set of characteristic loads (see 6.3);
15. Movements – horizontal and vertical;
16. Required spring rate;
17. Required gaps and specification of their direction for guides;
18. Specification of required friction coefficient for supports and guides (to be stated in a note);
19. Minimum ambient temperature;
20. Corrosion aggressivity of the environment;
21. Desired surface finish.

If no piping category or support class is specified, the piping will be classified as the one with the highest requirements.

#### 9.8.1.2. CHARACTERISTIC LOAD VALUES

The characteristic load values are equal to the values obtained from the piping stress and flexibility analysis or specifications.

Table 8-1.2 provides their description.

Table 8-1-2

Type of support	Fixed	Spring
Characteristic cold load value	Equals to dead weight of the piping including content and insulation at normal reference ambient temperature	Required spring pre-set load
Characteristic hot load value	Loads for the condition with the highest operating pipeline temperature or for the load condition with the highest loads	Load for the condition with operating or design temperature under nominal standard operating condition
Characteristic values of occasional loads	Pressure test – load value for piping filled with test fluid at test temperature	

If the characteristic operating (hot) load is specified for spring supports, the characteristic cold load is calculated, using the values of vertical travel and spring rate.

Pressure test – load shall always be specified if it exceeds 1.16 times the value of design cold load provided in the specifications.

#### 9.8.1.3. DISPLACEMENTS

The characteristic values of displacement are equal to the values obtained from the piping stress and flexibility analysis or specifications.

Table 9.8.1-3 provides description of characteristic displacements

Table 9.8.1-3

Type of support	Fixed	Spring
Characteristic value of cold displacement	Displacement value for a filled pipeline at a normal reference ambient temperature	Displacement value for a filled pipeline at a normal reference ambient temperature
Characteristic value of hot displacement	Highest displacement value of all permanent load conditions	Vertical displacement – for the condition with a working or design temperature in a standard operational nominal condition
Horizontal displacements – the highest displacement value of all permanent load conditions	Pressure test – force value for filled pipeline at a test temperature	

For supports and guides, it is necessary that the maximum displacements are specified unambiguously and unmistakably in the local coordinate system, otherwise the support may fall from the structure, or the slide plates/rollers may get jammed!







**Moravia Systems a.s.**

Engineering:  
+420 775 427 510  
[engineering@moraviasystems.cz](mailto:engineering@moraviasystems.cz)

Manufacturing:  
Průmyslová 1760, 696 42 Vracov  
+420 778 727 198  
[info@moraviasystems.cz](mailto:info@moraviasystems.cz)

[www.moraviasystems.cz](http://www.moraviasystems.cz)