



- designed for process, steam or condensate piping systems
- wafer type body, disc and spring made of stainless steel
- metal-metal seat
- automatic operating

APPLICATION

- cooling systems
- food industry
- chemical industry



ADVANTAGES

- reliable prevention of backflow
- easy installation in horizontal, vertical or inclined pipes
- short face to face
- low pressure drop
- quiet operation
- maintenance-free operation

TECHNICAL DATA

Working range:	water, steam and other non-aggressive fluids in temperature range -25 °C to +260 °C, max. working pressure depending on temperature
Face to face:	EN 558-1, serie 49
Connection:	between flanges according to EN 1092-1, B1 / DIN PN10/16/25/40
Testing:	check valves are tested according to EN 12266 and supplied with accompanying documentation according to EN 10204

DESIGN AND CONSTRUCTION MATERIALS

Table 1 List of materials

Pos.	Name of part	Material
1	Body	A351 CF8M
2	Disc	A351 CF8M
3	Spring	AISI 316
4	Spring holder	AISI 316
5	Screw	AISI 316

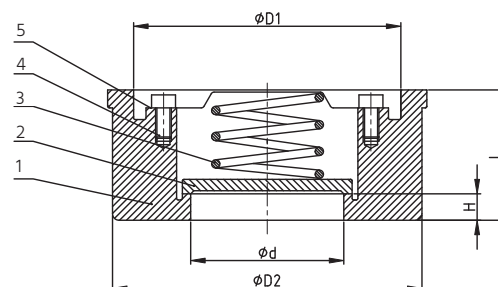
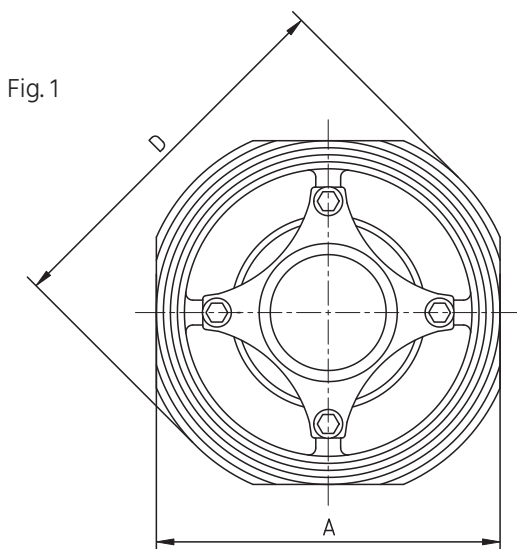

MAIN DIMENSIONS (in mm)

Table 2

DN	d	D	D1	D2	A	L	H	weight (kg)
15	15	53	38	43	45	16,5	4,40	0,11
20	20	63	46,5	53	55	19,5	4,80	0,19
25	25	73	55,5	63	65	22	5,40	0,30
32	30	84	65	75	78	28	6,00	0,40
40	38	94	75	86	88	31,5	6,60	0,60
50	47	107	84	96	98	40	7,10	0,88
65	62,5	126	103	115	118	46	7,80	1,26
80	77	144	117	130	134	50	8,40	1,86
100	96	164	137	151	154	60	9,00	3,30

PRESSURE – TEMPERATURE DIAGRAM

Graph 1

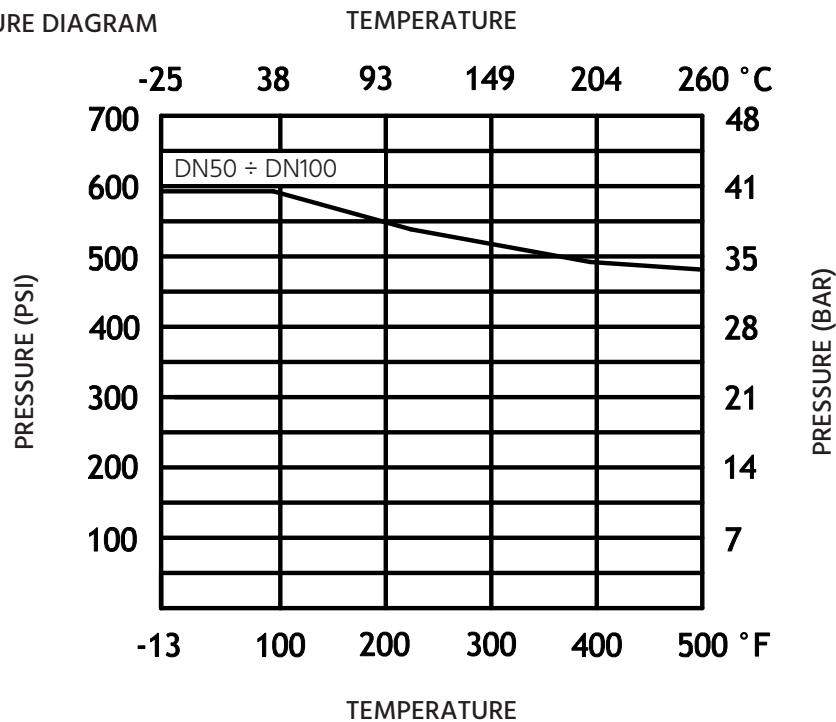

OPENING PRESSURES AND FLOW COEFFICIENT VALUES

Table 3

DN	Opening pressure (mbar)	Flow coefficient Kv (m³/h)
15	38	4,9
20	34	8,8
25	24	11,2
32	18	20,7
40	30	29
50	25	40
65	30	57
80	25	85
100	20	92

The information in the catalog sheet is for information only and the manufacturer reserves the right to make technical changes.