



DESIGN:

- according to MSS SP-110, EN12516
- full bore
- 3-PC body, floating ball, TFM 1600 seats
- KV-L30 – threaded BSPP ends acc. to ISO 228
- KV-L31 – welding ends (BW) – ASME B16.25 (ØB1 Sch40)
- ISO5211 top flange for direct mounting of operating locking device
- spindle protected against firing in case of overpressure
- compensating hole preventing the concentration of pressure in the space between ball and body
- antistatic (ball - spindle - body)
- flanges acc. to EN1092-1
- testing according to EN12266-1 P10, P11, P12 tightness A (water, air)
- production of castings in accordance with technical regulation TUV AD 2000-Merkblatt W0

CERTIFICATION:

- PED 2014/68/EU
- NACE MR-0175
- TA-Luft/ISO15848-1

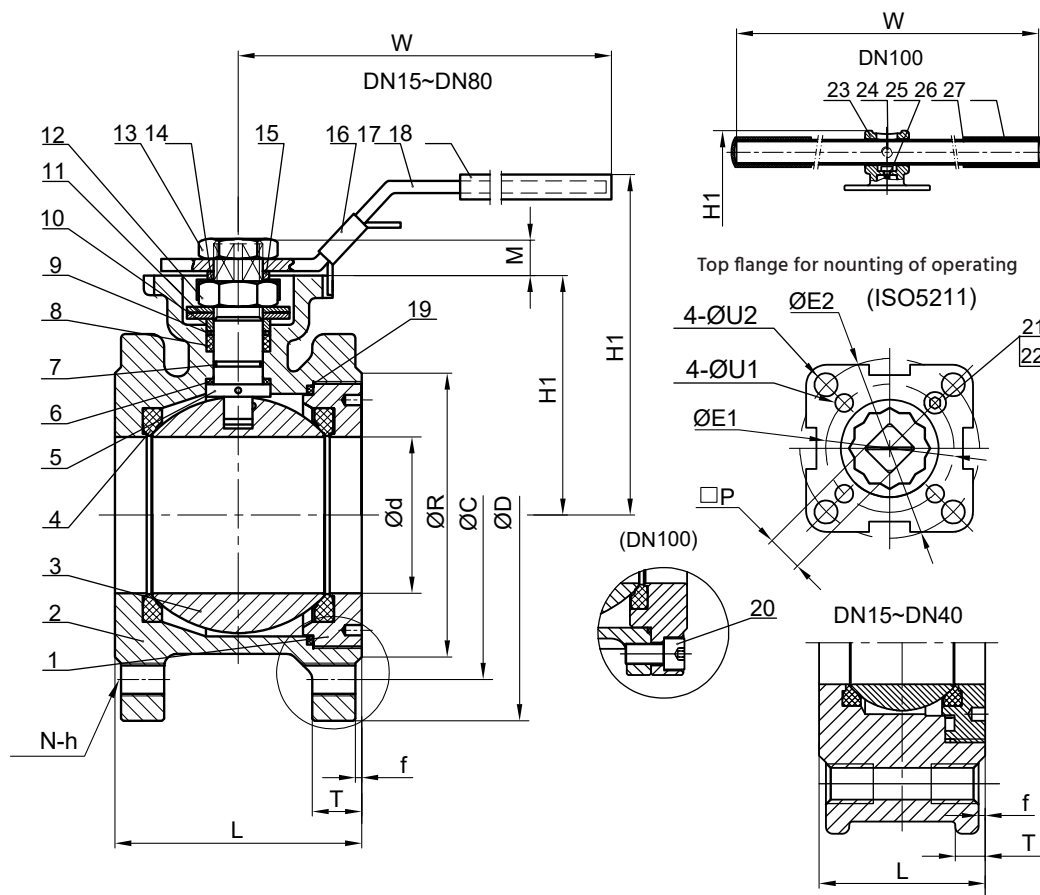

GENERAL DIMENSIONS AND WEIGHT

Dimensions are in mm.

DN	PN	d	R	C	D	f	T	L	H1	H	E	P	N	h	W	E1	E2	U1	U2	ISO5211	kg
15		15	45	65	95	2	9	42	78	48	9	9	4	M12	147	36	42	6	6	F03~F04	1,38
20	10	20	58	75	105	2	9	44	85	54	9	9	4	M12	147	36	42	6	6	F03~F04	1,76
25	16	25	68	85	115	2	9	50	94	62	11	11	4	M12	177	42	50	6	7	F04~F05	2,35
32	25	32	78	100	140	2	12	60	104	72	11	11	4	M16	177	42	50	6	7	F04~F05	3,88
40	40	38	88	110	150	3	13	65	114	78	14	14	4	M16	197	50	70	7	9	F05~F07	4,83
50		50	102	125	165	3	20	80	120	86	14	14	4	M16	197	50	70	7	9	F05~F07	6,64
65	10/16	63,5	122	145	185	3	18	110	158	108	17	17	4	M16	267	70	102	9	11	F07~F10	10,07
	22						113	10,68													
80	10/16	76,0	138	160	200	3	20	120	165	116	17	17	8	M16	267	70	102	9	11	F07~F10	14,65
	24						120	14,65													
100	10/16	95	158	180	220	3	20	150	212	140	22	22	8	M16	400	-	102	-	11	F10	22,92
	24		154	M20	26,96																

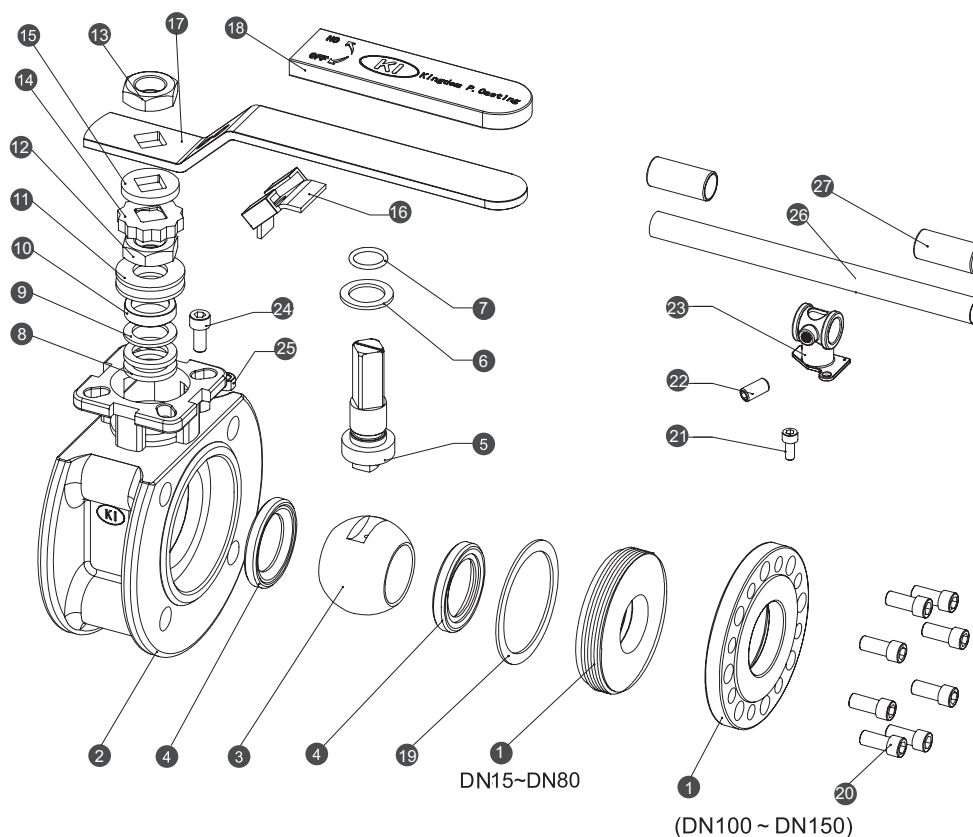

CONSTRUCTION AND MATERIALS

Pos.	Component name	Material
1	Bonnet	1.4408
2	Body	1.4408
3	Ball	CF8M/F316
4	Seats	TFM1600
5	Spindle	316
6	Axial sliding washer	PTFE
7	O-ring	FKM
8	Packing	Grfit
9	Spacer ring	304
10	Packing case	316
11	Disc spring	301
12	Spindle nut	A194-8
13	Nut of lever (DN15~DN80)	304
14	Lock washer	304

Pos.	Component name	Material
15	Lever washer	304
16	Locking device (DN15~DN80)	304
17	Hand lever (DN15~DN80)	304
18	Cover of lever (DN15~DN80)	VINYL
19	Body seal	316 Spiral wound +Graphite
20	Screws (DN100~DN150)	A2-70
21	Stop screw	A2-70
22	Stop nut	A2-70
23	Lever adapter (DN80~DN150)	CF8
24	Adjusting screw (DN80~DN150)	A2-70
25	Nut (DN80~DN150)	A2-70
26	Pipe of lever (DN80~DN150)	A53+Zn
27	Cover of lever (DN80~DN150)	Vinyl

FLOW COEFFICIENT Cv, Kv

DN	Cv [US gal.mm-1]	Kv [m³.h-1]
15	18	15,57
20	36	31,14
25	48	41,52
32	93	80,45
40	165	142,73
50	207	179,06
65	450	389,25
80	780	674,70
100	1360	1176,40

DEPENDENCE OF TORQUE ON PRESSURE DIFFERENCE ΔP

DN	ΔP ₁		ΔP ₂		ΔP ₃		ΔP ₄	
	5 bar	75 psi	10 bar	150 psi	16 bar	300 psi	40 bar	600 psi
	[Nm]	[lb _f -in]	[Nm]	[lb _f -in]	[Nm]	[lb _f -in]	[Nm]	[lb _f -in]
15	5	44	5	5	5	44	5	44
20	6	53	6	6	6	53	6	53
25	10	88	10	10	11	97	11	97
32	13	115	13	13	15	133	17	150
40	19	168	19	19	22	195	24	212
50	25	221	29	29	32	283	34	301
65	40	354	45	45	49	434	52	460
80	65	575	72	72	81	717	88	779
100	100	885	110	110	122	1080	132	1168

For design of an actuator it is necessary to take into account the safety factor (recommended min. 30%).

PRESSURE-TEMPERATURE DIAGRAM

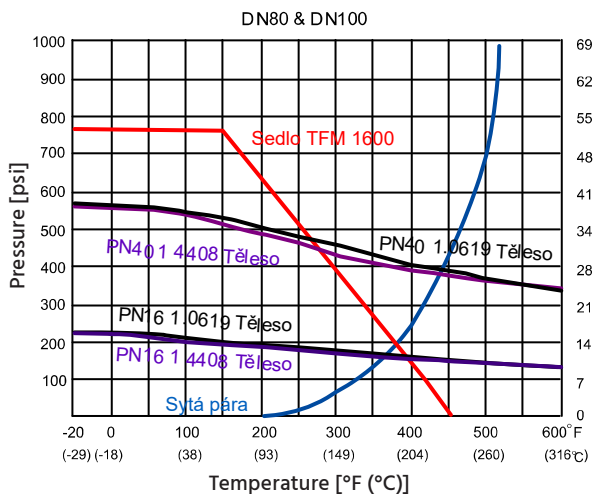
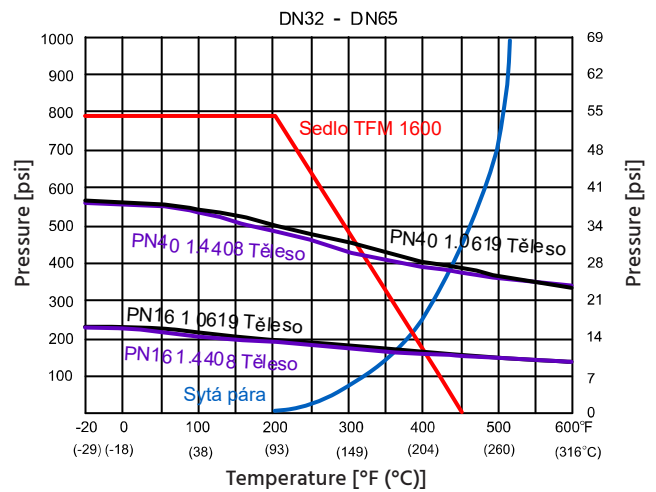
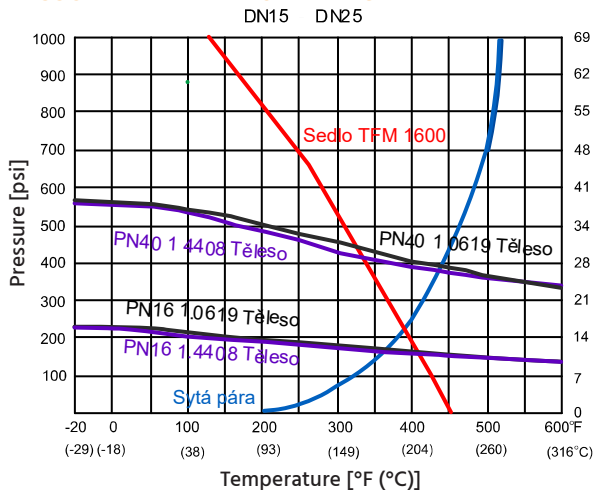

Sedlo = Seat
 Těleso = Body
 Sytá pára = Saturated steam

BALL VALVE KV-L7NF / PN40 DN15 – DN50 WIT PRISMA DOUBLE-ACTING PNEUMATIC ACTUATOR

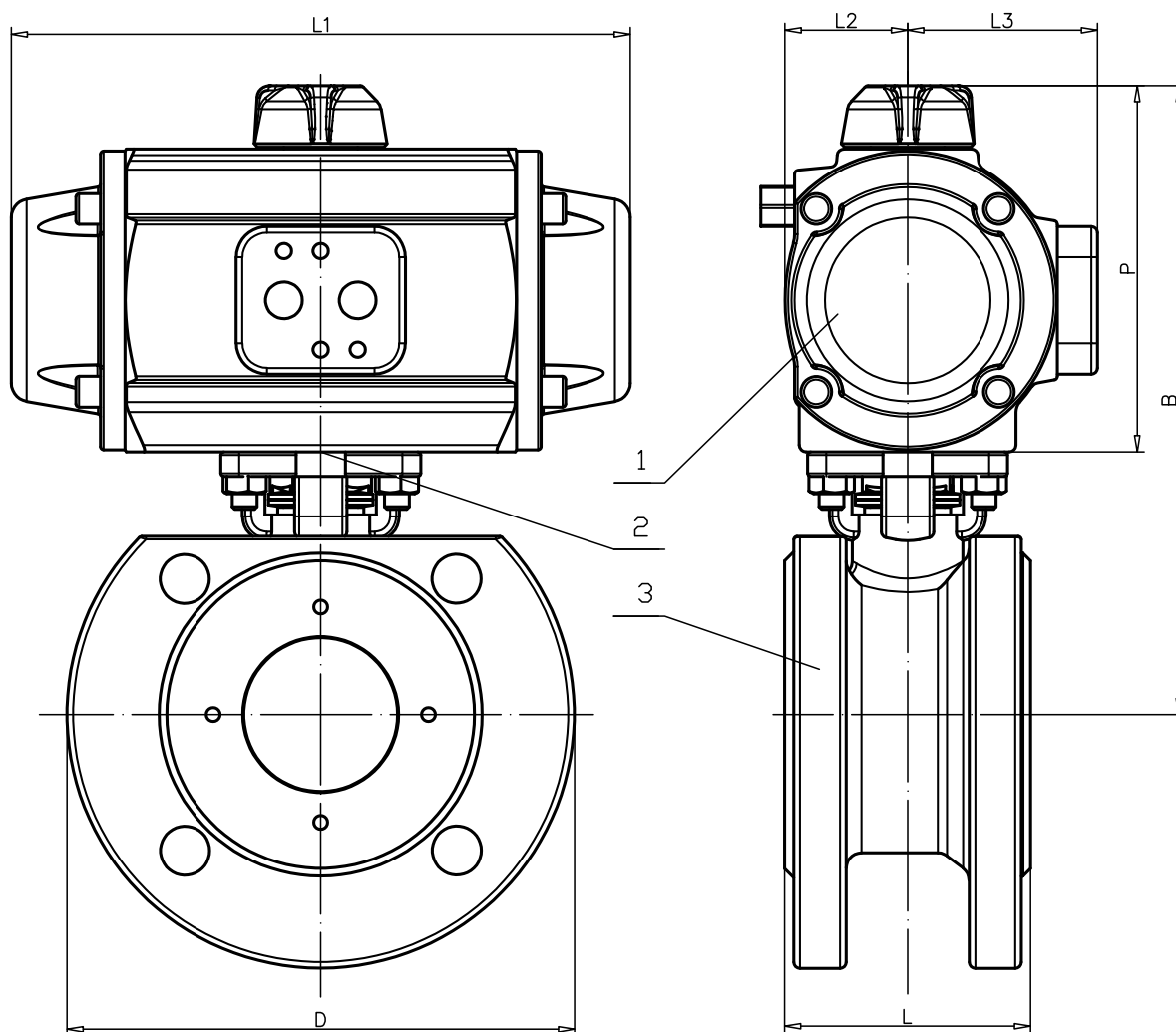

Position	Name of component
1	Double-acting pneumatic actuator
2	Mounting kit
3	Ball valve

Wafer ball valve KV-L7NF with Prisma D/A pneumatic actuator										
DN	PN	Actuator	D	L	P	L1	L2	L3	B	Kg
15	40	PAW	95	42	89	141	28	48	137	2,6
20	40	PAW	95	42	89	141	28	48	137	3
25	40	PAW	115	50	89	141	28	48	151	3,4
32	40	PA00	140	60	102	155	32	52	174	5,6
40	40	PA05	150	65	119	201	40	62	197	7,8
50	40	PA05	165	80	119	201	40	62	205	9,6

BALL VALVE KV-L7NF / PN40 DN15 – DN50 WITH PRISMA SINGLE-ACTING PNEUMATIC ACTUATOR

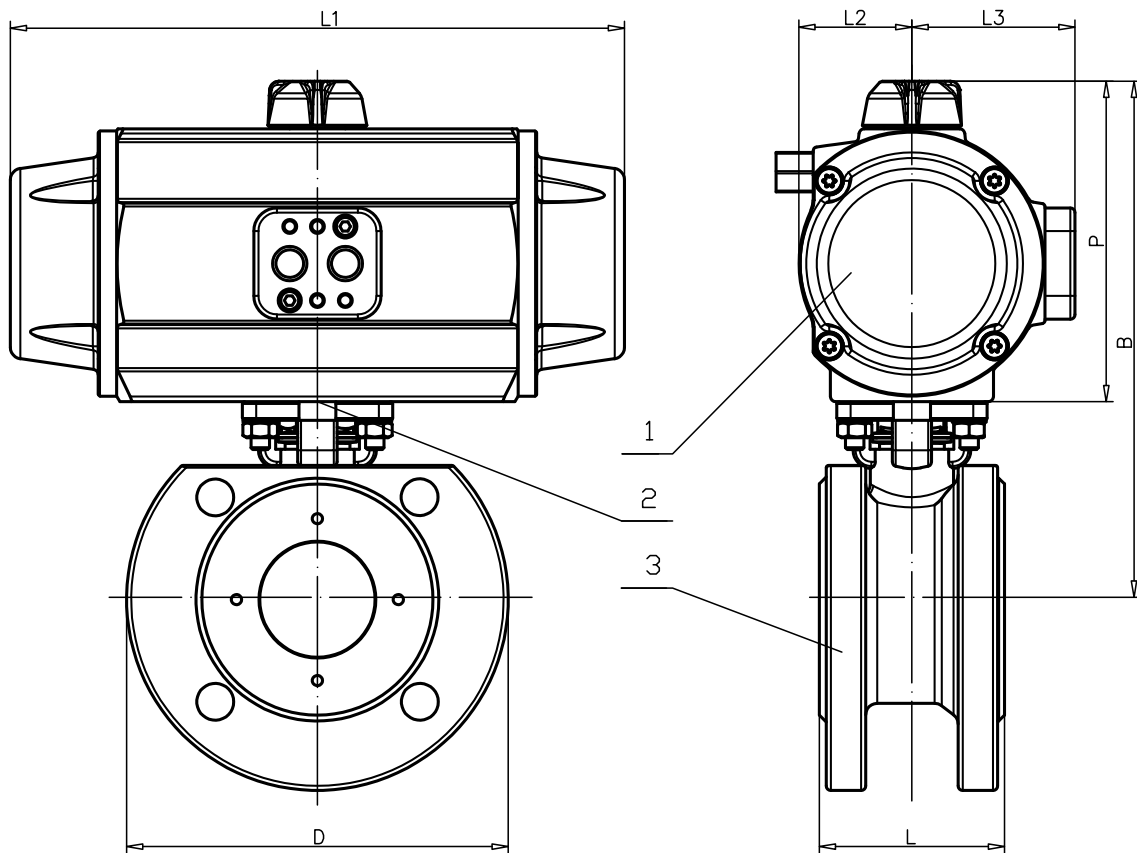

Position	Name of component
1	Single-acting pneumatic actuator
2	Mounting kit
3	Ball valve

Wafer ball valve KV-L7NF with Prisma S/A pneumatic actuator										
DN	PN	Actuator	D	L	P	L1	L2	L3	B	Kg
15	40	PAWS	95	42	89	141	28	48	137	2,7
20	40	PA00S	105	44	102	155	32	52	156	3,7
25	40	PA05S	115	50	119	201	40	62	181	5,6
32	40	PA10S	140	60	119	201	40	62	191	7,7
40	40	PA15S	150	65	139	265	48	71	217	10,3
50	40	PA15S	165	80	139	265	48	71	225	12,2

BALL VALVE KV-L7KF / PN16 DN65 – DN100 WITH PRISMA DOUBLE-ACTING PNEUMATIC ACTUATOR

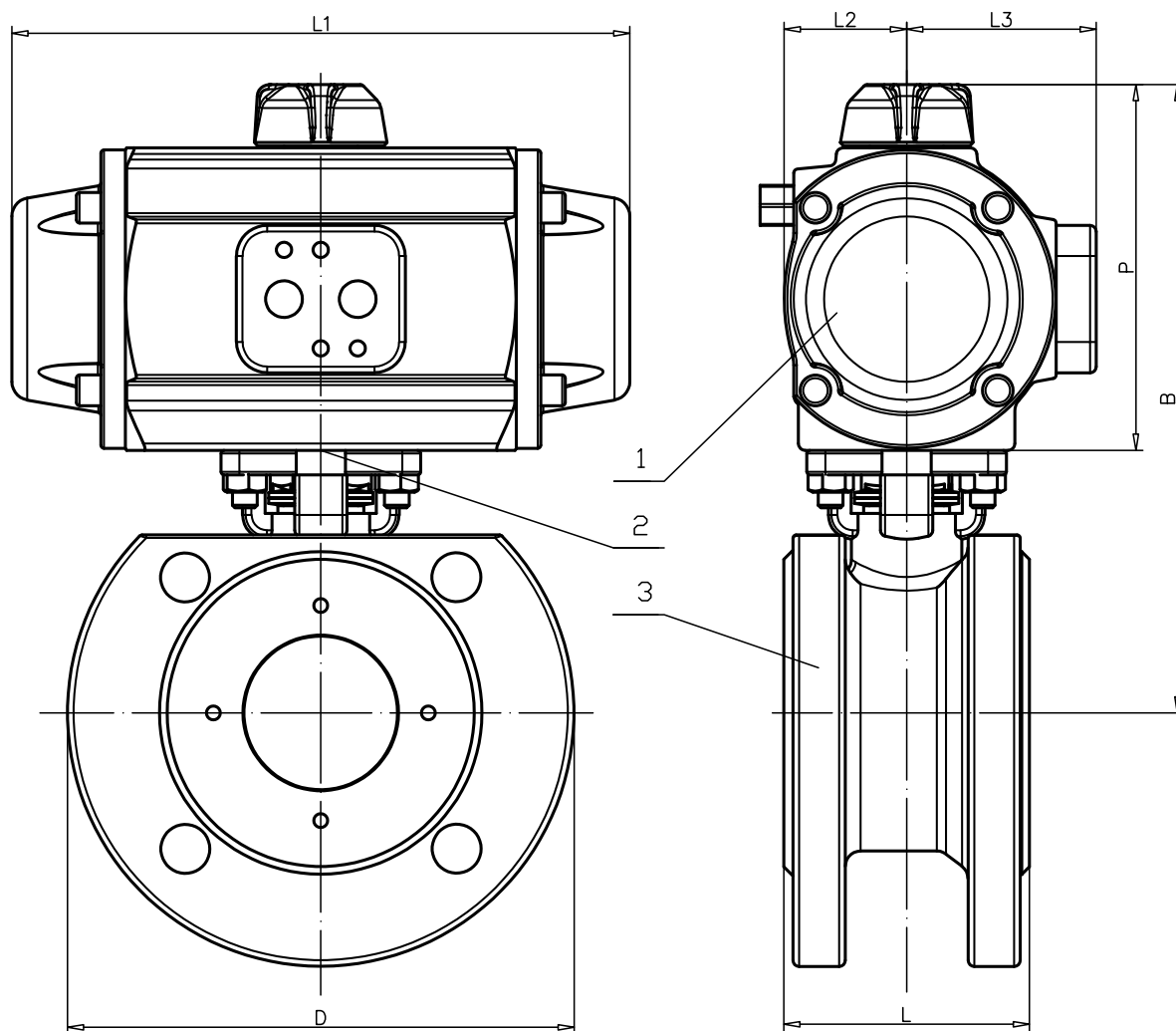

Position	Name of component
1	Double-acting pneumatic actuator
2	Mounting kit
3	Ball valve

Wafer ball valve KV-L7KF with Prisma D/A pneumatic actuator										
DN	PN	Actuator	D	L	P	L1	L2	L3	B	Kg
65	16	PA10	185	110	123	226	41	63	231	13,6
80	16	PA15	200	120	139	265	48	71	255	19,3
100	16	PA25	220	150	139	265	48	71	279	34

BALL VALVE KV-L7KF / PN16 DN65 – DN100 WITH PRISMA SINGLE-ACTING PNEUMATIC ACTUATOR

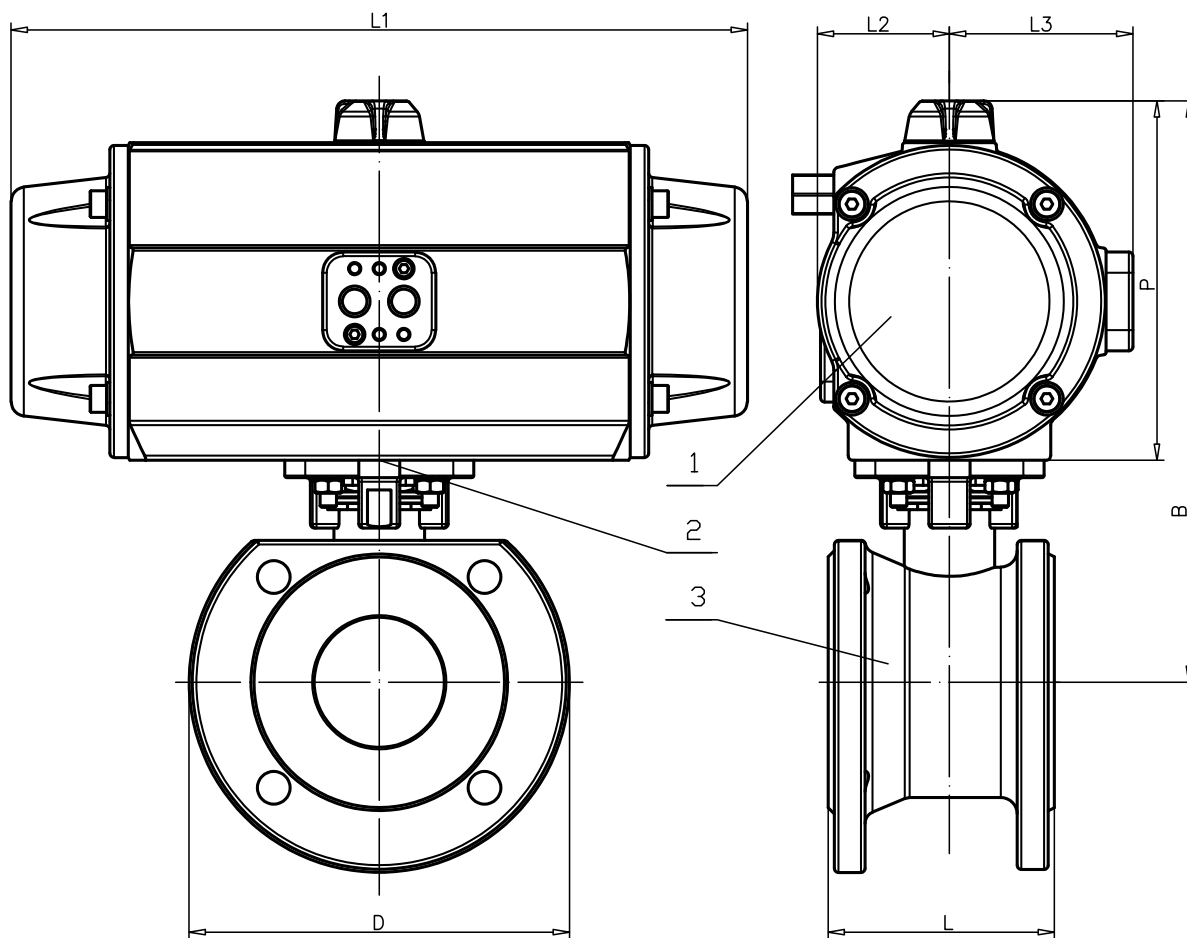

Position	Name of component
1	Single-acting pneumatic actuator
2	Mounting kit
3	Ball valve

Wafer ball valve KV-L7KF with Prisma S/A pneumatic actuator										
DN	PN	Actuator	D	L	P	L1	L2	L3	B	Kg
65	16	PA25S	185	110	123	358	64	89	283	22
80	16	PA25S	200	120	139	358	64	89	291	27
100	16	PA30S	220	150	139	429	72	97	331	40

CERTIFICATES

ISO 9001

ISO 14001

OHSAS 18001

PED 2014/68/EU

AD2000-W0

AD2000-HP0

AD2000- A4

DNV

SIL 3

TA-Luft

ISO 15848-1

ATEX 94/9/EC

EN 14432

API 6D

API607 / ISO10497

CRN

CU-TR

CCS

TS

Lloyd's Register

Bureau Veritas



The data in the catalog sheet are for information only and the manufacturer reserves the right to make technical changes.