

- design BS 5351
- full bore
- split body, floating ball, PTFE seats
- ISO 5211 top flange
- DN ≥ 25 antistatic device
- fire safe BS 6755, API 6FA, API 607

APPLICATION

- piping systems for processing, treatment and transport of liquid and gaseous media

ADVANTAGES

- low weight
- low pressure loss
- easy installation and maintenance
- high corrosion resistance
- reliability
- possibility of automatic operation

TECHNICAL DATA

Working fluid:	non-aggressive liquids and gases (water, steam, oil, air, fuel gases, oil and oil derivatives) depending on construction materials of valve
Working temperature:	from -10 °C to +180 °C
Max. working pressure:	more in Pressure/Temperature Diagram
Construction materials:	more in table of Materials of main construction parts
Face to face:	EN 558-1, serie 27
Flanges:	EN 1092-1, B1/ PN 16/40

The ball valve is a two-way shut-off valve intended for installation in horizontal or vertical piping. The shut-off element is a ball with a through hole, which rotates through 90 ° and closes the working fluid flow in the seats. The ball valve is not suitable for abrasive working media and coagulating liquids. It is designed to operate either in the OPEN or CLOSED position.

Operating:	hand wheel
Option:	from DN 150 gearbox with hand wheel on request electric or pneumatic operating antistatic device for DN 15 – DN20 degreasing service delivery including counter-flanges, sealing and bolting material

Testing: each ball valve shall be tested in accordance with EN 12266 and supplied with accompanying documentation according to EN 10204

Certification: PED 2014/68/ EU
ATEX 94/9/ CE

DESIGN AND CONSTRUCTION MATERIALS

Fig. 1

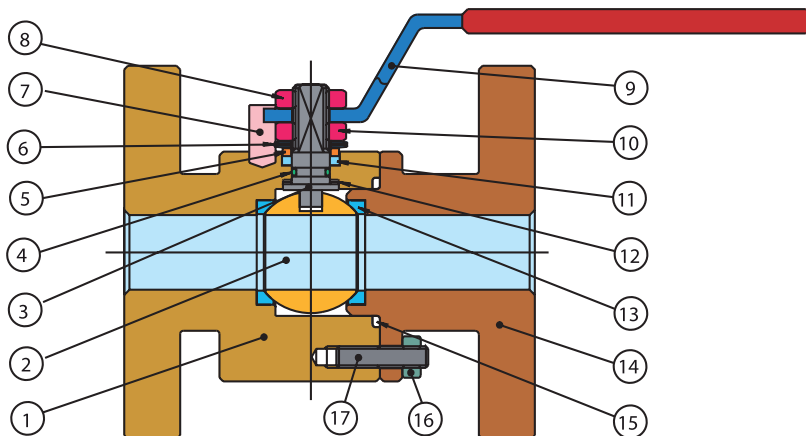

Table 1 Materials of main construction parts

Pos.	Description	Material
1	Body	ASTM A 105
2	Ball	AISI 304 (DIN 1.4301)
3	Stem	AISI 304 (DIN 1.4301)
4	O-ring	Viton
5	Washer	AISI 304 (DIN 1.4301)
6	Spring washer	50 Cr V4
7	Operation - stop	uhlíková ocel 8.8
8	Fixing nut	A 105 Nickel-plated
9	Hand lever	A 105 Nickel-plated
10	Stem nut	A 105 Nickel-plated
11	Packing	PTFE
12	Thrust washers	PTFE
13	Seats	PTFE
14	Body flange	ASTM A 105*
15	Static gasket	PTFE
16	Locking nut	ASTM A 105 Nickel-plated
17	Stud bolt	A 193 B7

TECHNICAL DRAWING AND DIMENSIONS

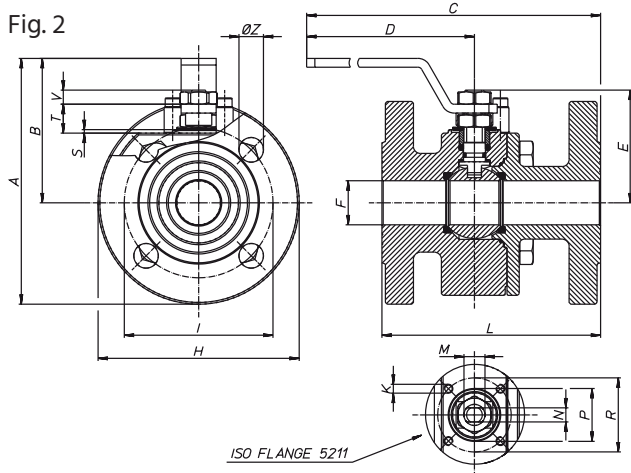
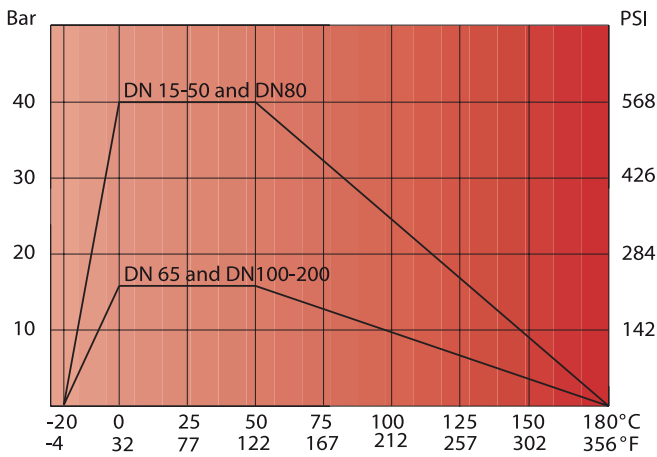

Table 2

Size	Dimension (mm)																			PN	ISO 5211	kg
	A	B	C	D	E	F	G	H	K	I	L	M	N	P	R	S	T	V	Number of wholes			
DN 15	40	113,5	66	207	140	48	15	14	95	M5	65	115	M10	6	-	36	-	5	9	4	F03	3,60
DN 20	40	121,5	69	210	140	51	20	14	105	M5	75	120	M10	6	25	36	2	8	9	4	F03	4,64
DN 25	40	139,5	82	252	180	62,3	25	14	115	M5	85	125	M12	8	30	42	2	11,5	11,5	4	F04	5,75
DN 32	40	157	87	257	180	67	32	18	140	M5	100	130	M12	8	30	42	2	10	11	4	F04	8,32
DN 40	40	183	108	312	230	87,3	40	18	150	M6	110	140	M16	10	35	50	2,5	14,5	15,5	4	F05	11,16
DN 50	40	197,5	115	317	230	94,5	49,5	18	165	M6	125	150	M22	10	35	50	2,5	14,5	15,5	4	F05	14,90
DN 65	40	231	139	418	320	119,5	65	18	185	M8	145	185	M22	14	55	70	3	18,7	20,8	4	F07	23,75
DN 80	40	250	150	425	320	130	78	18	200	M8	160	180	M22	14	55	70	3	18,7	20,8	8	F07	28,53
DN 100	40	281	163	484	370	148,5	96	22	235	M10	190	190	M27	16	-	102	-	1,5	26	8	F10	35,56
DN 100	16	273	163	484	370	148,5	96	18	220	M10	190	190	M27	16	-	102	-	1,5	26	8	F10	35,56
DN 125	16	309	181	603	370	166,5	118	18	250	M10	210	325	M27	16	70	102	3	22	26	8	F10	65,50
DN 150	16	392	249	771	584	200	144	22	285	M12	240	350	M42	26	-	125	-	4	31,5	8	F12	108,90
DN 200	16	460	288	784	584	235	192	22	343	M12	295	400	M42	26	-	125	-	4	27	12	F12	194,65

PRESSURE/ TEMPERATURE DIAGRAM - TOPAZ PN16/40



HEAD LOSS DIAGRAM - TOPAZ PN16/40

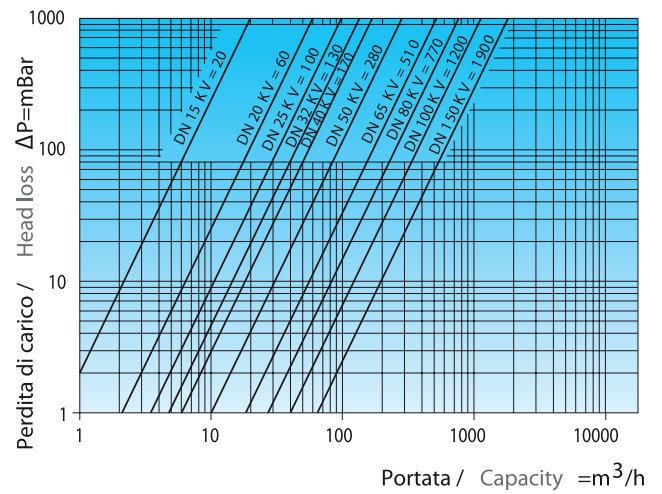

BREAKING TORQUES - TOPAZ PN 16/40

DN	15	20	25	32	40	50	65	80	100	125	150	200
PN (bar)												
0	4	7	15	21	26	36	51	81	130	240	310	600
16	5	8	17	23	28	39	54	86	150	300	400	800
40	6	10	22	28	32	45	62	120	200	475	900	1800

Note:

For safe operation of valves with pneumatic or electric control, the relevant safety factor must be taken into account when dimensioning the actuator.

TECHNICAL DRAWING AND DIMENSIONS OF BALL VALVE TOPAZ PN16 DN 100 ÷ 200 AND PN40 DN 15 ÷ 100 WITH DOUBLE-ACTING PNEUMATIC ACTUATOR

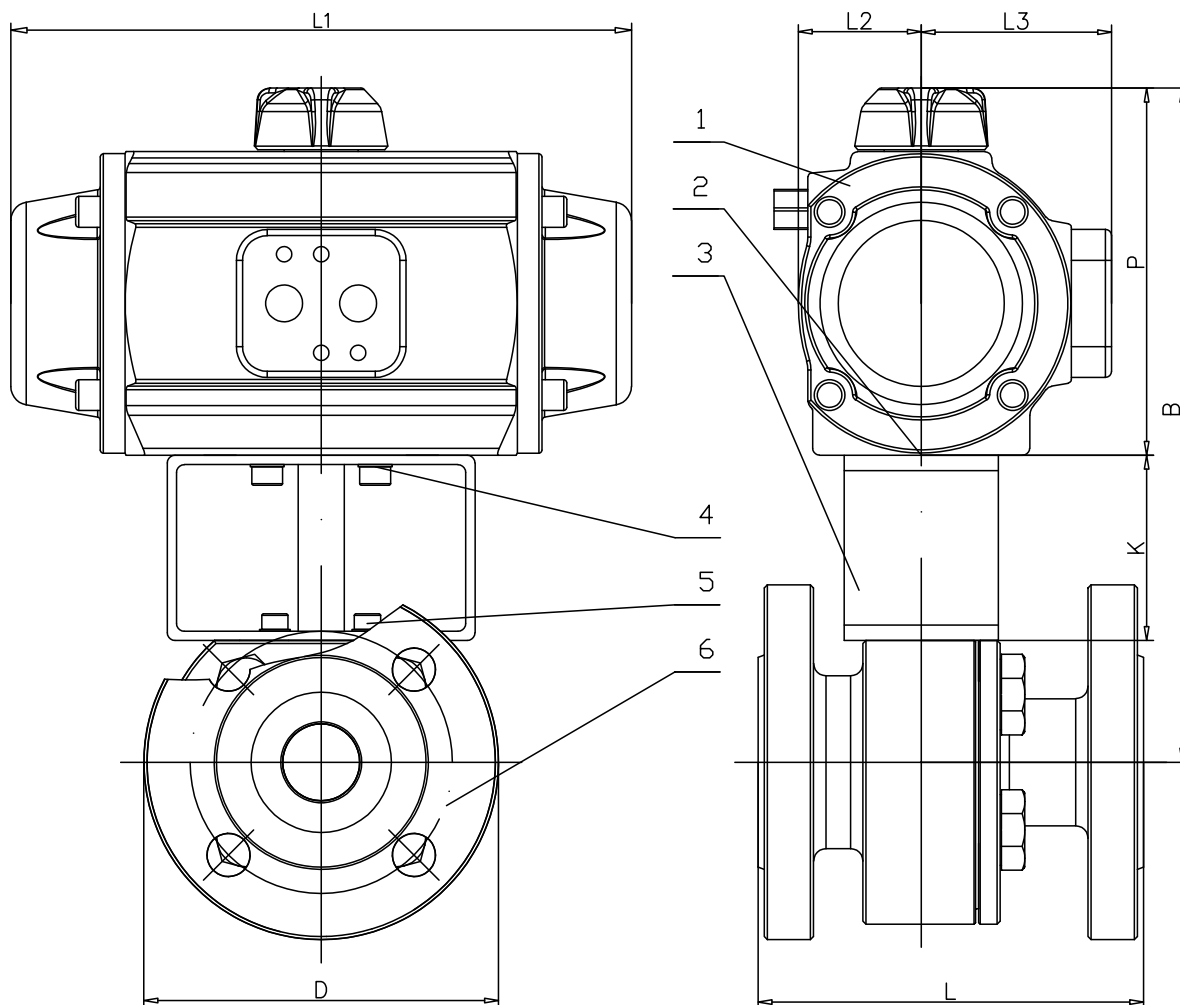

1	Dvojitý pneumatický pohon / Double acting pneumatic actuator										
2	Vložka / Connection										
3	Montážní sada / Mounting Kit										
4	Šrouby / Bolts A										
5	Šrouby / Bolts B										
6	Kulový kohout / Ball valve TOPAZ										
Kohout kulový přírubový s dvojitým pneumatickým pohonem TOPAZ											
Flanged ball valve with doubleacting pneumatic actuator TOPAZ											
DN	PN	Pohon / Actuator	D	L	K	P	L1	L2	L3	B	Kg
15	40	PAW	95	115	60	89	141	28	48	183	5,4
20	40	PAW	105	120	60	89	141	28	48	183	6,4
25	40	PA05	115	125	60	119	201	40	62	219	9,3
32	40	PA05	140	130	60	119	201	40	62	225	12
40	40	PA05	150	140	60	119	201	40	62	237	14,9
50	40	PA10	165	150	60	123	226	41	63	248	19,3
65	40	PA15	185	170	80	139	265	48	71	299	30,2
80	40	PA20	200	180	80	147	312	52	75	318	37
100	40	PA25	235	190	80	175	358	64	89	376	49,5
100	16	PA25	220	190	80	175	358	64	89	376	48
125	16	PA30	250	325	80	191	429	72	97	391	80
150	16	P40	285	350	80	272	444	106	120	517	132
200	16	P40	343	400	80	272	444	106	120	557	218

TECHNICAL DRAWING AND DIMENSIONS OF BALL VALVE TOPAZ PN16 DN 100 ÷ 200 AND PN40 DN 15 ÷ 100 WITH SINGLE-ACTING PNEUMATIC ACTUATOR

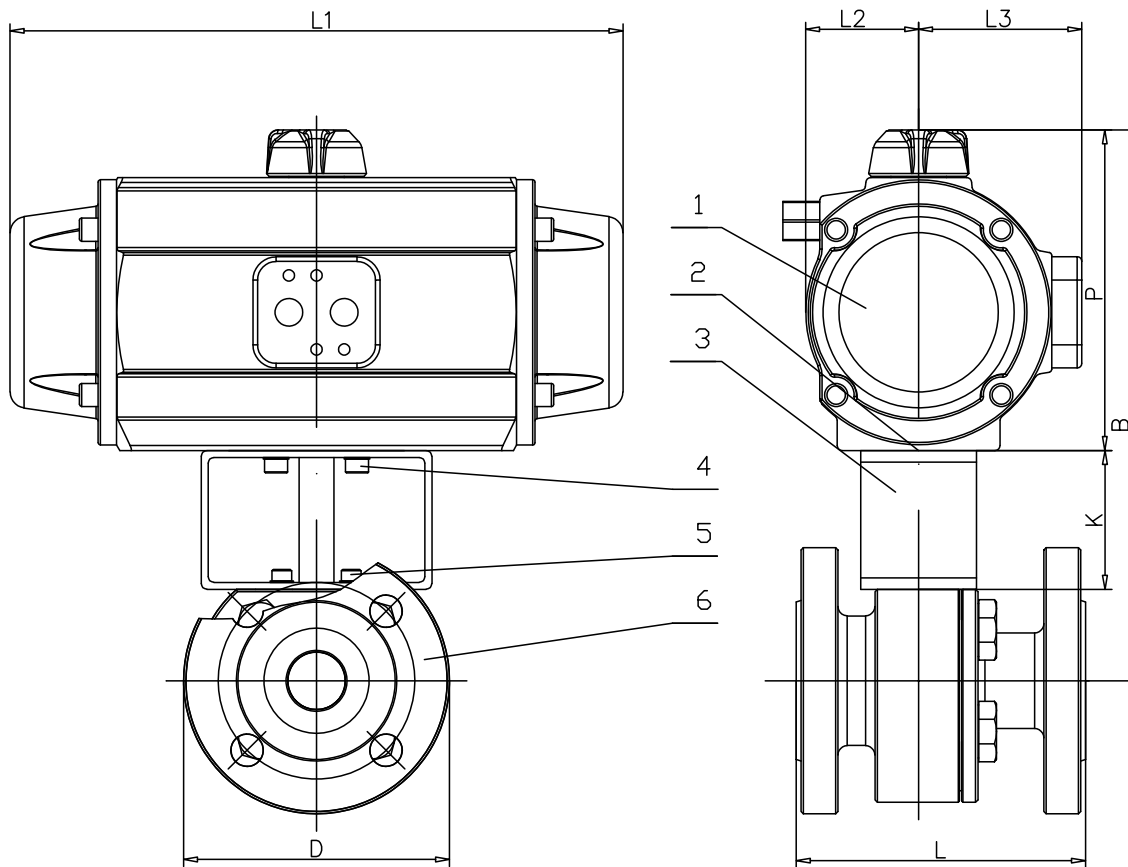

1	Jednočinný pneumatický pohon / Single acting pneumatic actuator										
2	Vložka / Connection										
3	Montážní sada / Mounting Kit										
4	Šrouby / Bolts A										
5	Šrouby / Bolts B										
6	Kulový kohout / Ball valve TOPAZ										
Kohout kulový přírubový s jednočinným pneumatickým pohonem TOPAZ Flanged ball valve with single acting pneumatic actuator TOPAZ											
DN	PN	Pohon / Actuator	D	L	K	P	L1	L2	L3	B	Kg
15	40	PA00S	95	115	60	102	155	32	52	196	6,1
20	40	PA05S	105	120	60	119	201	40	62	213	8,5
25	40	PA15S	115	125	60	139	265	48	71	239	12,2
32	40	PA15S	140	130	60	139	265	48	71	245	14,7
40	40	PA15S	150	140	60	139	265	48	71	257	14,9
50	40	PA20S	165	150	60	147	312	52	75	272	23,3
65	40	PA25S	185	170	80	175	358	64	89	335	38
80	40	PA30S	200	180	80	191	429	72	97	362	47
100	40	P40S	235	190	80	272	598	106	120	473	77
100	16	P40S	220	190	80	272	598	106	120	473	75
125	16	P40S	250	325	80	272	598	106	120	472	105
150	16	PA50S	285	350	90	309	694	128	141	564	171
200	16	PA60S	343	400	120	368	672	160	185	693	283

The data given in the catalog are informative and the manufacturer reserves the right to make technical changes.