



- design EN 13709
- straight cast body
- wedled seat
- rising stem with outside screw and yoke
- asbestos-free packing

APPLICATION

- water or steam distribution
- cooling systems
- petrochemical or chemical industry

ADVANTAGES

- compliance of emission standards
- easy installation and maintenance
- long service life



TECHNICAL DATA

Working range: water, steam, natural gas, oil, petroleum derivates and another non-aggressive working fluids;
temperature range from -10 °C to +400 °C

The allowable pressure/temperature rating acc. to EN 12516:

Nominal pressure	Material	Max. working pressure (bar) – Temperature (°C)						
		100 °C	150 °C	200 °C	250 °C	300 °C	350 °C	400 °C
PN 40	GP240GH	37,1	35,2	33,3	30,4	27,6	25,7	23,8

Construction materials: carbon steel (pls see more in table of materials of main parts)

Face to face: EN 558-1, serie 1

Flanges: EN 1092-1, B1/ DIN PN40

Straight globe valves have a flow direction of the working fluid equal to the direction of the arrow on the body and are designed to operate in the OPEN or CLOSED position. They are not suitable for flow control in the basic version.

Operating: hand wheel

Options: hand wheel with lock
hand wheel with limit switches
operating by electric actuator
other types of coatings according to customer requirements
delivery including counter-flanges, bolting and sealing material

Testing: each globe valve is tested according to EN 12266 and supplied with accompanying documentation according to EN 10204

Certification: PED 2014/68/ EU

DESIGN AND CONSTRUCTION MATERIALS

Fig.1 DN 15 – DN 50

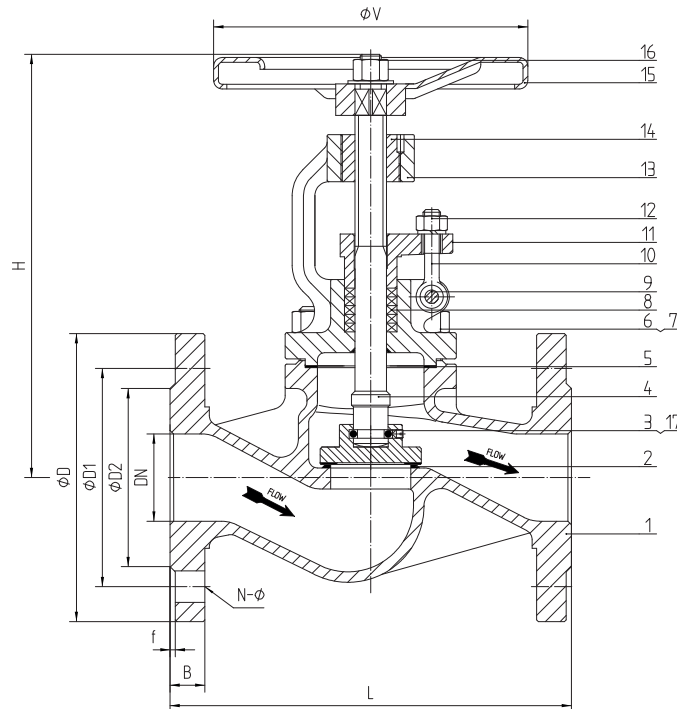
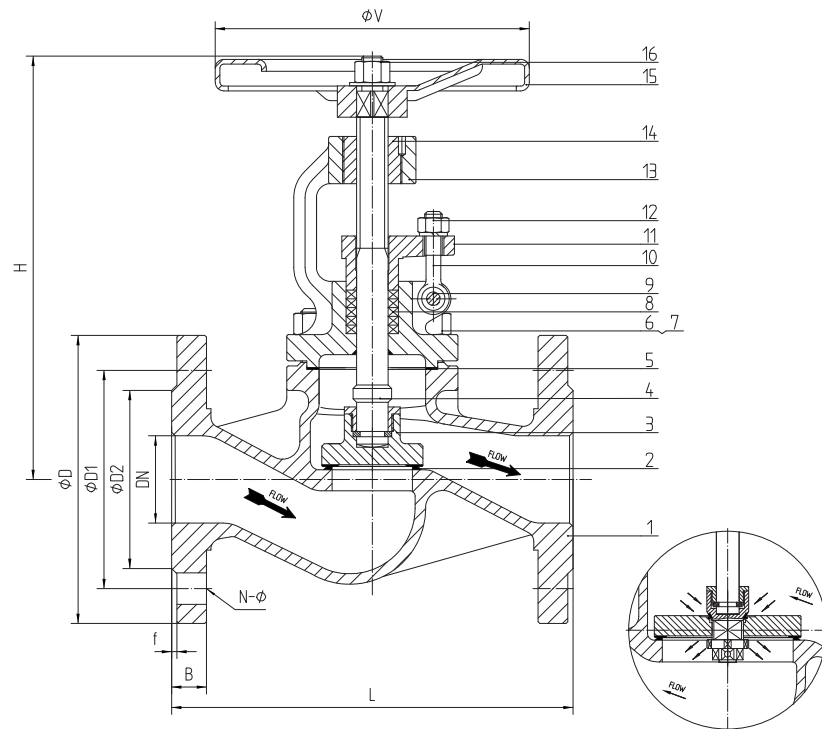

Fig.2 DN 65 – DN 150



DN125 - DN150 IS BALANCING PLUG DISC DESIG

Table 1 Materials of main parts DN 15 – DN 150

Position	Description	Material	Position	Description	Material
1	Body	GP240GH ¹⁾	10	Eye bolt	ASTM A193 B7
2	Seat	X2013Cr	11	Gland	GP240GH ¹⁾
3	Disc	C22.8 + X20Cr13	12	Nut	ASTM A194 2H
4	Stem	X2013Cr	13	Bonnet	GP240GH ¹⁾
5	Gasket	AISI304 + graphite	14	Stem nut	GGG40.3
6	Nut	ASTM A194 2H	15	Hand wheel	steel
7	Bolt	ASTM A193 B7	16	Lock nut	stainless steel
8	Packing	Graphite	17	Bearing of disc ²⁾	AISI304
9	Pin	AISI301			

1) with protective paint, thickness 40-100 μm , colour RAL 5002

2) DN 15 – DN 50

Fig. 3 DN 200

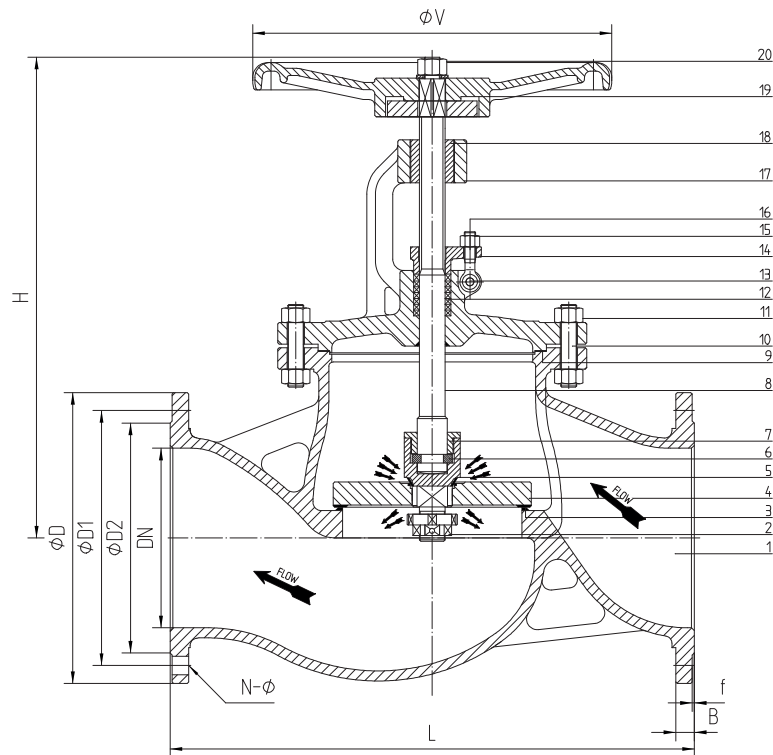

Table 2 Materials of main parts DN 200

Position	Description	Material	Position	Description	Material
1	Body	GP240GH ¹⁾	11	Nut	ASTM A194 2H
2	Bolt	C22.8	12	Packing	Graphite
3	Body seat	X2013Cr	13	Pin	AISI301
4	Disc	C22.8	14	Gland	GP240GH ¹⁾
5	Disc seat	C22.8 + STL 6	15	Nut	ASTM A194 2H
6	Ring	X10Cr13	16	Eye bolt	ASTM A193 B7
7	Bolt	C22.8	17	Bonnet	GP240GH ¹⁾
8	Stem	X2013Cr	18	Stem nut	Cu- alloy
9	Gasket	AISI304 + graphite	19	Hand wheel	EN GJS 400-18
10	Bolt	ASTM A193 B7	20	Lock nut	AISI304

1) with protective paint, thickness 40-100 µm, colour RAL 5002

GENERAL DIMENSIONS (mm)

DN	PN	L	D	D1	D2	B	f	N-Ø	H	Stroke	ØV
15	40	130	95	65	45	16	2	4×14	190	10	140
20		150	105	75	58	18	2	4×14	197	12	140
25		160	115	85	68	18	2	4×14	217	16	160
32		180	140	100	78	18	2	4×18	218	18	160
40		200	150	110	88	18	3	4×18	252	20	180
50		230	165	125	102	20	3	4×18	259	22	180
65		290	185	145	122	22	3	8×18	294	24	200
80		310	200	160	138	24	3	8×18	332	29	250
100		350	235	190	162	24	3	8×22	359	34	300
125		400	270	220	188	26	3	8×26	440	42	350
150		480	300	250	218	28	3	8×26	490	52	400
200		600	375	320	285	34	3	12×30	576	85	450

The data in this datasheet are informative only and the manufacturer reserves the right to changes of technical details.