



- 2-PC wafer type cast body, short face to face, full bore
- knife passes between the two parts of bolted body
- knife with special guide for fast and trouble-free closing
- metal or soft sealing seat (2 seats)
- rising stem
- wide range of material options for soft elastomer seats
- low torque

APPLICATION

- paper industry
- food industry
- chemical industry
- sewage treatment plants, sludge management

ADVANTAGES

- low pressure drop
- low weight
- easy to install between flanges in or on the end of pipe (or under silo)
- low maintenance costs
- long service life



TECHNICAL DATA

Working medium: liquid substances with a maximum solids concentration of 20 % (eg. dense sludge, paper pulp), depending on construction materials of the knife gate valve

Maximal working pressure:

DN	Maximal working pressure (bar)
50 - 150	10
200	8
250 - 300	6
350 - 400	5
450 - 600	3
700 - 1200	2

Maximum temperature range: depends on the design and construction materials of the knife gate valves, working medium and working conditions

Types of seats:

Fig. 1

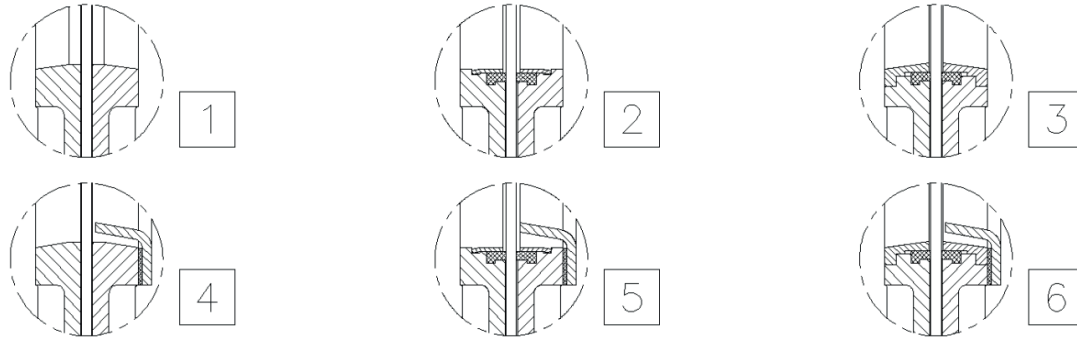

Types of seat

Types of seat	Tightness (%)
1 metal-metal	98,8
2 metal-elastomer	100
3 metal-elastomer with scraper to protect the seat from abrasion	100
4 metal-metal with deflector to protect the body from abrasion	98,8
5 metal-elastomer with deflector to protect the body from abrasion	100
6 metal-elastomer with scraper to protect the seat from abrasion and with deflector to protect the body from abrasion	100

Note: In order to select the appropriate type of seat and materials of body, knife, seat and packing don't hesitate to contact our sales department.

Face to face:	according to manufacturer
Installation between flanges acc. to:	EN 1092-1/ DIN PN10
Operating:	up to DN 500 – hand wheel DN 600 - 1200 – gear box with hand wheel
Options:	non-rising stem extended stem hand wheel with lock quick-closing lever chain wheel electric, pneumatic or hydraulic actuator low control knife position indicator limit switches other type or color of coating according to customer requirements delivery including counter-flanges, bolting and sealing material
Testing:	each knife gate valve is tested according to EN 12266 and supplied with accompanying documentation according to EN 10204
Certification:	PED 2014/68/EU ATEX (II, 2 a 22 GD) 94/9/ES

Fig. 2

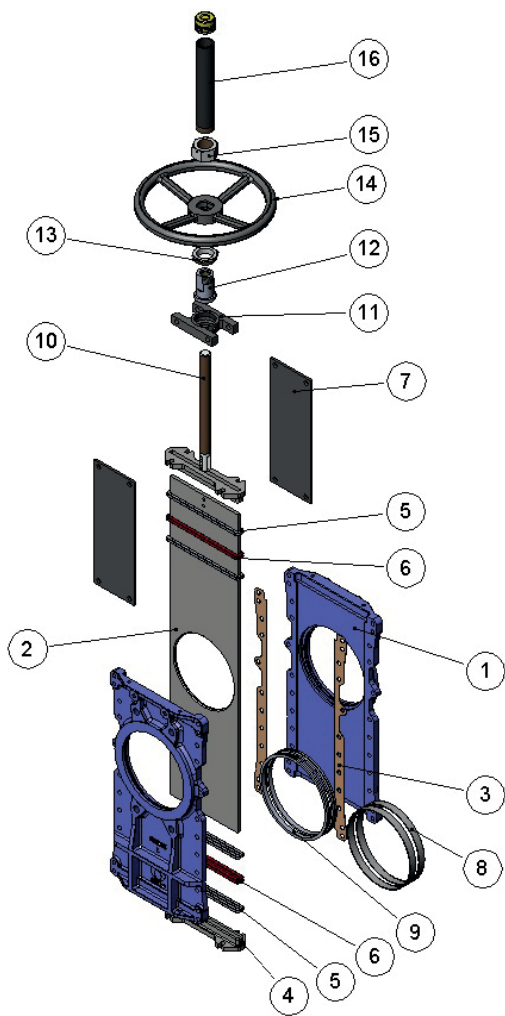

Pos.	Description	Basic material options of knife gate valve with EPDM seat
1	Body	GJL-250*) CF8M
2	Knife	AISI 304 AISI316
3	Body seal	sealing cardboard
4	Packing gland	GJS-500 CF8M
5	Packing	synt. + PTFE
6	O-ring	EPDM
7	Support plate	S275 JR
8	Metallic ring	AISI 316
9	Seat	EPDM
10	Stem	AISI 303
11	Yoke	Steel
12	Stem nut	bronze
13	Nut	ST 44.2 galvanized
14	Hand wheel	GJS-500
15	Nut	Steel
16	Hood	Steel

*) With epoxy protective coating: 80 µm, RAL 5015

DIMENSIONS

Serie L with hand wheel

Fig. 3

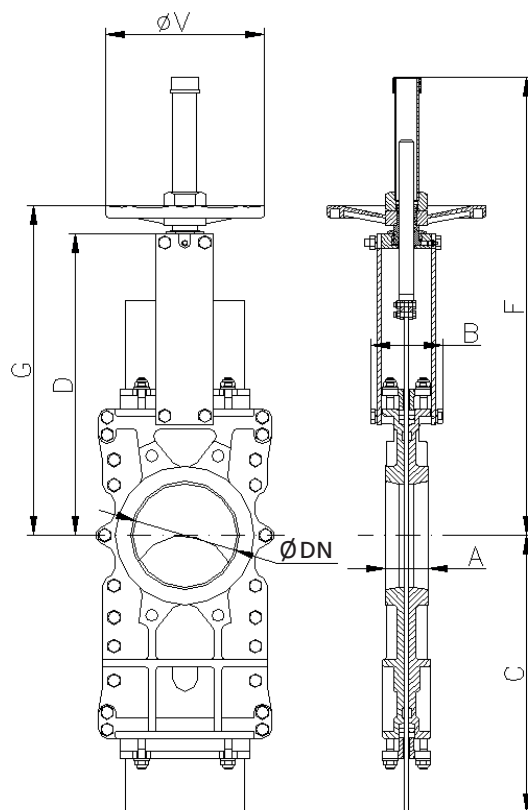

DN	ΔP (Kg/cm ²)	A	B	C	D	F	G	ØV	Kg
50	10	40	91	225	243	412	282	225	12
65	10	40	91	265	269	437	308	225	13
80	10	50	91	310	293	462	332	225	17
100	10	50	91	370	334	503	373	225	19
125	10	50	101	430	367	586	407	225	28
150	10	60	101	495	419	638	458	225	38
200	8	60	118	630	525	816	578	325	54
250	6	70	118	770	620	1017	679	325	88
300	6	70	118	895	704	1117	779	380	112
350	5	96	290	1050	780	1337	906	450	163
400	5	100	290	1185	855	1443	1012	450	235
450	3	106	290	1320	975	1629	1098	450	368
500	3	110	290	1455	1064	1741	1210	450	471
600	3	110	292	1720	1244	2047	1416	450	532

Serie L with gear box

Fig. 4

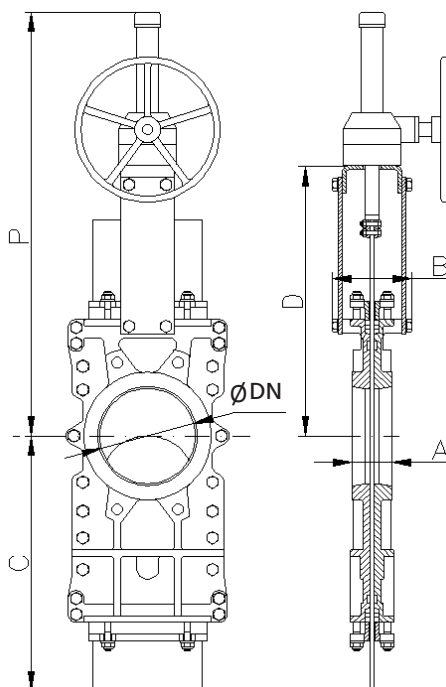

DN	ΔP (Kg/cm ²)	A	B	C	D	P	Kg
50	10	40	91	225	243	540	22
65	10	40	91	265	269	566	23
80	10	50	91	310	293	591	27
100	10	50	91	370	334	631	28
125	10	50	101	430	367	665	37
150	10	60	101	495	419	717	47
200	8	60	118	630	525	943	76
250	6	70	118	770	620	1037	111
300	6	70	118	895	726	1171	133
350	5	96	290	1050	780	1318	163
400	5	100	290	1185	855	1393	247
450	3	106	290	1320	975	1662	386
500	3	110	290	1455	1064	1752	495
600	3	110	290	1720	1244	1981	552
700	2	110	320	1995	1425	2320	956
800	2	110	320	2230	1615	2610	1186
900	2	110	320	2465	1823	2913	1522
1000	2	110	320	2620	1992	3206	1892
1100	2	150	340	3030	2217	3777	2232
1200	2	150	340	3250	2351	4042	2621

Serie L with quick-closing lever

Fig. 5

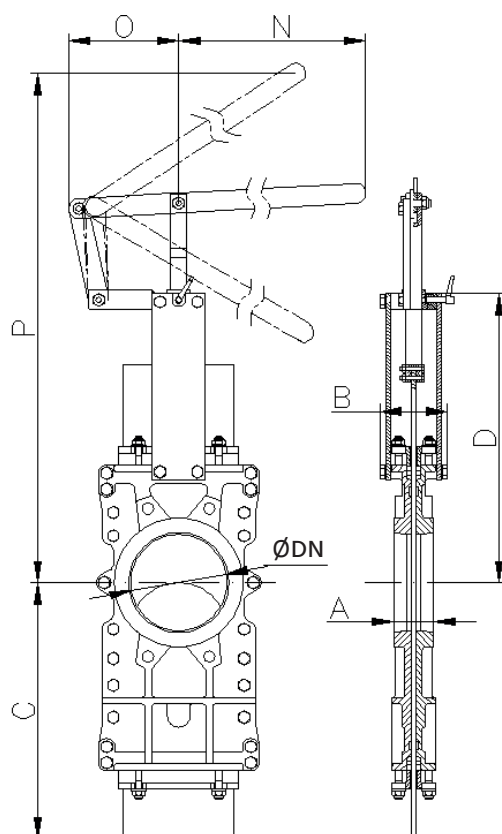

DN	ΔP (Kg/cm ²)	A	B	C	D	N	O	P	Kg
50	10	40	91	225	243	325	155	504	13
65	10	40	91	265	269	325	155	526	14
80	10	50	91	310	293	325	155	549	18
100	10	50	91	370	334	325	155	605	20
125	10	50	101	430	367	425	155	902	29
150	10	60	101	495	419	425	155	956	39
200	8	60	118	630	525	620	290	1027	55
250	6	70	118	770	620	620	290	1416	89
300	6	70	118	895	704	620	290	1525	113

Serie L with chain wheel

Fig. 6

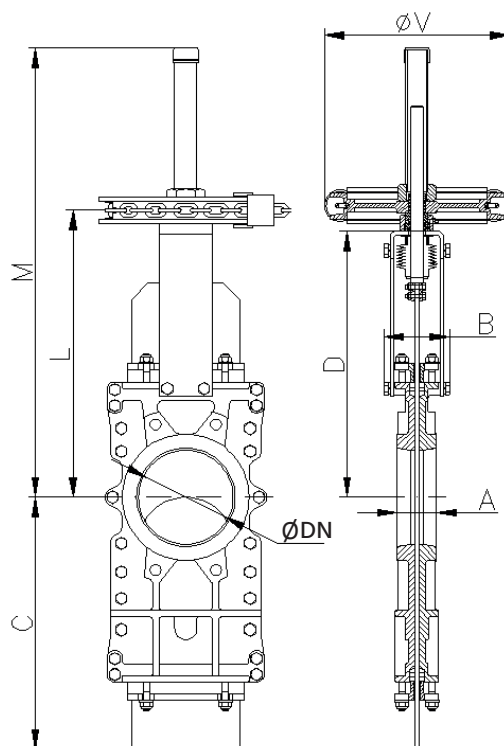

DN	ΔP (Kg/cm ²)	A	B	C	D	L	M	$\varnothing V$	kg
50	10	40	91	225	243	294	437	225	12
65	10	40	91	265	269	319	464	225	13
80	10	50	91	310	293	346	490	225	17
100	10	50	91	370	334	386	530	225	19
125	10	50	101	430	367	420	613	225	28
150	10	60	101	495	419	471	665	225	38
200	8	60	118	630	525	602	849	300	54
250	6	70	118	770	620	697	1050	300	88
300	6	70	118	895	704	797	1150	300	112
350	5	96	290	1050	780	918	1398	402	163
400	5	100	290	1185	855	998	1504	402	²³⁵
450	3	106	290	1320	975	1078	1690	402	368
500	3	110	290	1455	1064	1201	1802	402	471
600	3	110	290	1720	1244	1329	2108	402	532
700	2	110	320	1995	1425	1606	2406	402 [*]	936
800	2	110	320	2230	1615	1820	2720	402 [*]	1166
900	2	110	320	2465	1823	2053	3053	402 [*]	1502
1000	2	110	320	2620	1992	2257	3337	402 [*]	1872
1100	2	150	340	3030	2217	2546	3676	402 [*]	2212
1200	2	150	340	3250	2351	2836	4016	402 [*]	2601

Note: DN700–DN1200 with gear and chain wheel

Serie L with double-acting pneumatic actuator

Fig. 7

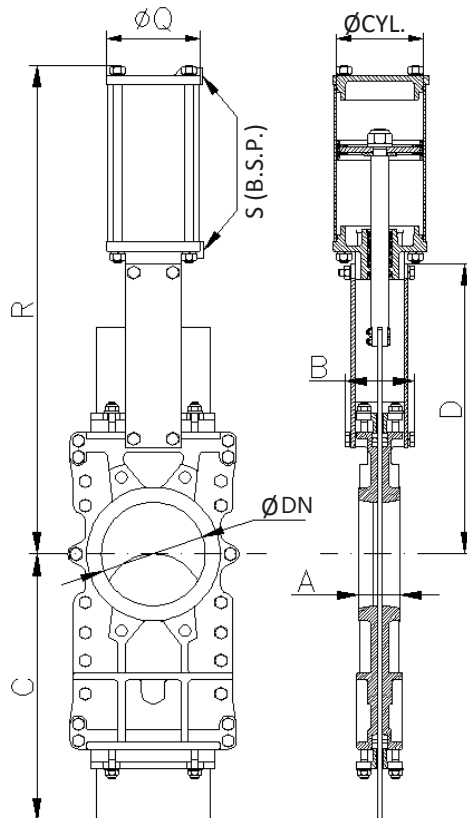

DN	ΔP (Kg/cm ²)	axial force (N)	A	B	C	D	R	Ø cylinder	Ø piston rod	Ø Q	S (B.S.P.)	Kg
50	10	894	40	91	225	243	416	80	20	90	1/4"	12
65	10	1508	40	91	265	269	456	80	20	90	1/4"	13
80	10	2281	50	91	310	293	497	80	20	90	1/4"	19
100	10	3561	50	91	370	334	561	100	20	110	1/4"	19
125	10	5565	50	101	430	367	636	125	25	135	1/4"	33
150	10	6419	60	101	495	419	717	160	30	170	1/4"	43
200	8	10020	60	118	630	525	874	200	30	215	1/4"	65
250	6	11230	70	118	770	620	1030	200	30	215	3/8"	104
300	6	16210	70	118	895	704	1160	250	40	270	3/8"	126
350	5	17740	96	290	1050	780	1364	250	40	270	3/8"	200
400	5	23260	100	290	1185	855	1482	250	40	270	3/8"	281
450	3	22260	106	290	1320	975	1662	250	40	270	1/2"	427
500	3	27470	110	290	1455	1064	1802	300	45	382	1/2"	540
600	3	39850	110	290	1720	1244	2081	350	45	444	1/2"	509
700	2	36880	110	320	1995	1425	2400	350	45	444	1/2"	1054
800	2	48980	110	320	2230	1615	2693	350	45	444	1/2"	1284
900	2	61230	110	320	2465	1823	3037	400	50	508	1/2"	1620

Note:

The control air pressure of a standard pneumatic actuator is in the range of 6–10 kg / cm². In order to design a suitable pneumatic if the control air pressure is less than 6 bar, please contact our sales department.

Typ L s 1-činným pneumatickým pohonem

Fig. 8

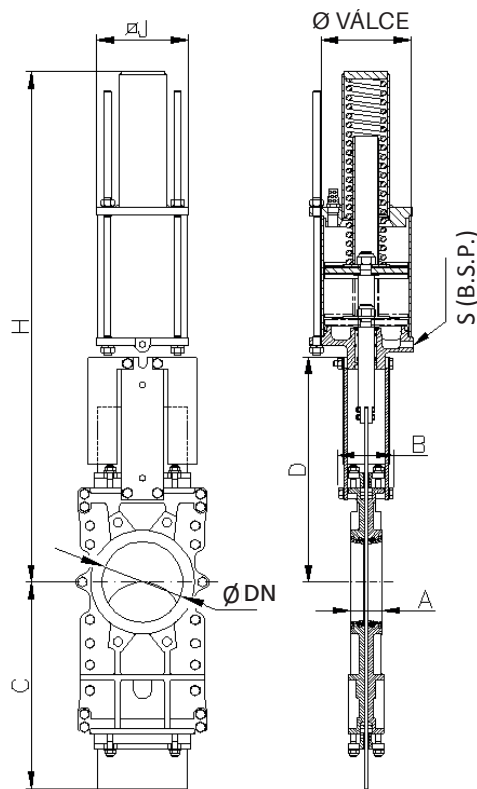

DN	ΔP (Kg/cm ²)	axial force (N)	A	B	C	D	H	Ø J	Ø cylinder	Ø piston rod	S (B.S.P.)	Kg
50	10	894	40	91	225	243	781	135	125	25	1/4"	12
65	10	1508	40	91	265	269	806	135	125	25	1/4"	13
80	10	2281	50	91	310	293	833	135	125	25	1/4"	19
100	10	3561	50	91	370	334	873	170	160	25	1/4"	19
125	10	5565	50	101	430	367	909	215	200	30	1/4"	33
150	10	6419	60	101	495	419	960	215	200	30	1/4"	43
200	8	10020	60	118	630	525	1355	270	250	30	3/8"	65
250	6	11230	70	118	770	620	1844	382	300	40	3/8"	104
300	6	16210	70	118	895	704	2005	382	300	40	3/8"	126

Note:

The control air pressure of a standard pneumatic actuator is in the range of 6–10 kg / cm². In order to design a suitable pneumatic if the control air pressure is less than 6 bar, please contact our sales department.

DIMENSIONS FOR ASSEMBLY BETWEEN FLANGES

ND	ΔP (Kg/cm ²)	○	●	M thread	depth	ØK
50	10	-	4	M 16	8	125
65	10	-	4	M 16	8	145
80	10	4	4	M 16	9	160
100	10	4	4	M 16	9	180
125	10	4	4	M 16	9	210
150	10	4	4	M 20	10	240
200	8	4	4	M 20	10	295
250	6	4	8	M 20	12	350
300	6	4	8	M 20	12	400
350	5	4	12	M 20	21	460
400	5	4	12	M 24	21	515
450	3	4	16	M 24	22	565
500	3	4	16	M 24	22	620
600	3	4	16	M 27	22	725
700	2	4	20	M 27	22	840
800	2	4	20	M 30	22	950
900	2	4	24	M 30	20	1050
1000	2	4	24	M 33	20	1160
1100	2	4	28	M 33	20	1270
1200	2	4	28	M 36	22	1380

Fig. 9

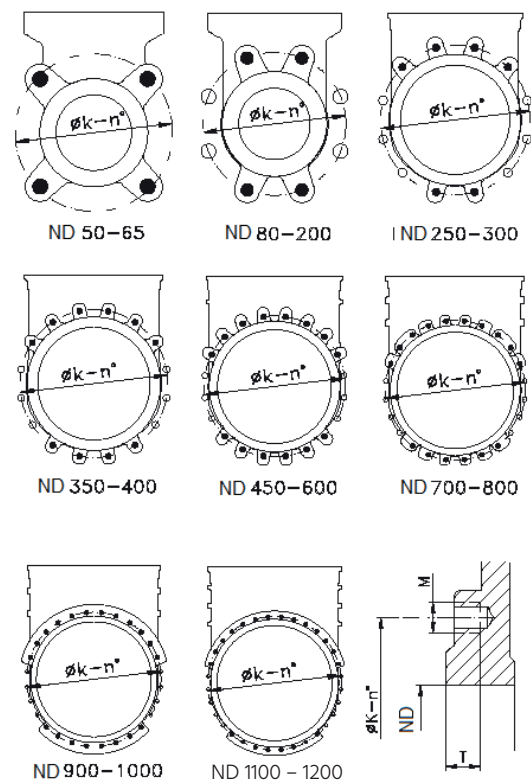

- through holes
- blind holes

The data in the catalogue are informative and the supplier reserves the right to make technical changes.