



- 1-PC wafer type cast body, short face to face
- full bore
- knife with special guide for fast and trouble-free closing
- soft elastomer seat
- rising stem
- wide range of material options for soft elastomer seat
- low torque

APPLICATION

- sewage treatment plants
- food industry
- chemical industry

ADVANTAGES

- low pressure drop
- low weight
- easy to install between flanges
- low maintenance costs
- long service life



TECHNICAL DATA

Working medium:

liquid substances with a maximum solids concentration till max. 5%, eg. waste water slightly polluted or filtered, depending on construction materials of the knife gate valve

Maximal working pressure:

DN	Max. working pressure (bar)
50 - 150	10
200	8
250 - 300	6
350 - 400	5
450 - 600	3

Maximum temperature range:

depends on the design and construction materials of the knife gate valves, working medium and working conditions

Fig.1 Type of seat

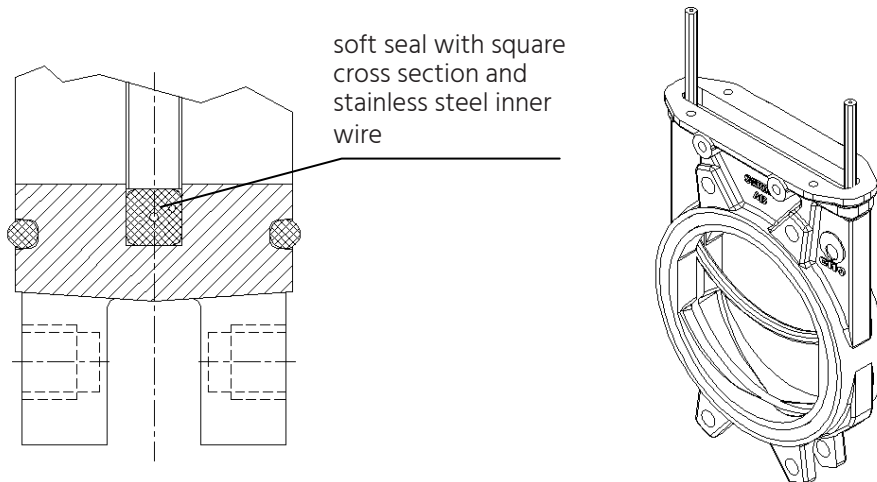

Knife gate valve serie AB is only available with a soft elastomer seat (type 2 metal-elastomer seat).

The soft seal is not around the hole, but only at the bottom, and has a U-shape (follows the shape of the knife). The inserted stainless steel wire helps the sealing element to maintain its shape and stable position in the body of valve. There is no accumulation of solid impurities in the seat area. The tightness of the seat is 100% in both directions of flow of working fluid.

Note:

In order to select the appropriate materials of body, knife, seat and packing don't hesitate to contact our sales department.

Face to face:	according to manufacturer
Installation between flanges acc. to:	EN 1092-1 / DIN PN10
Operating:	up to DN 600 – hand wheel
Options:	<ul style="list-style-type: none"> non-rising stem extended stem gear box quick-closing lever (DN 50–DN 200, $\Delta P = \text{max. } 2 \text{ kg/cm}^2$) chain wheel electric, pneumatic or hydraulic actuator mechanical locking device flow control with knife position indicator limit switches other type or color of coating according to customer requirements delivery including counter-flanges, bolting and sealing material
Testing:	each knife gate valve is tested according to EN 12266 and supplied with accompanying documentation according to EN 10204
Certification:	<ul style="list-style-type: none"> PED 2014/68/EU ATEX (II, 2 a 22 GD) 94/9/ES

Fig. 2

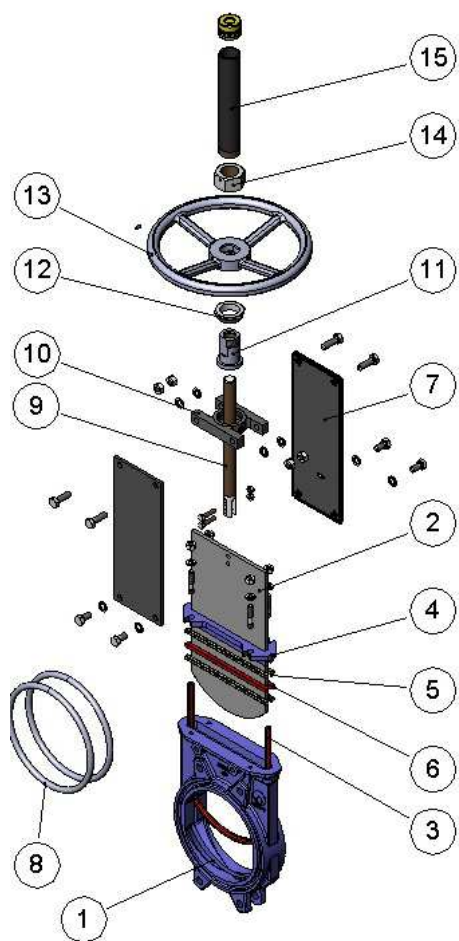

Pos.	Description	Basic material options of knife gate valve with EPDM seat
1	Body	GJS-500*) CF8M
2	Knife	AISI 304 AISI 316
3	Seat	EPDM
4	Packing gland	GJS-500*) CF8M
5	Packing	Synt. + PTFE
6	O-ring	EPDM
7	Support plate	S275JR
8	O-ring	NBR
9	Stem	AISI 303
10	Yoke	steel
11	Stem nut	bronze
12	Nut	ST44.2 galvanized
13	Hand wheel	modular cast iron
14	Nut	steel
15	Hood	steel

*) With epoxy protective coating: 80 µm, RAL 5015

DIMENSIONS

Serie AB with hand wheel

Fig. 3

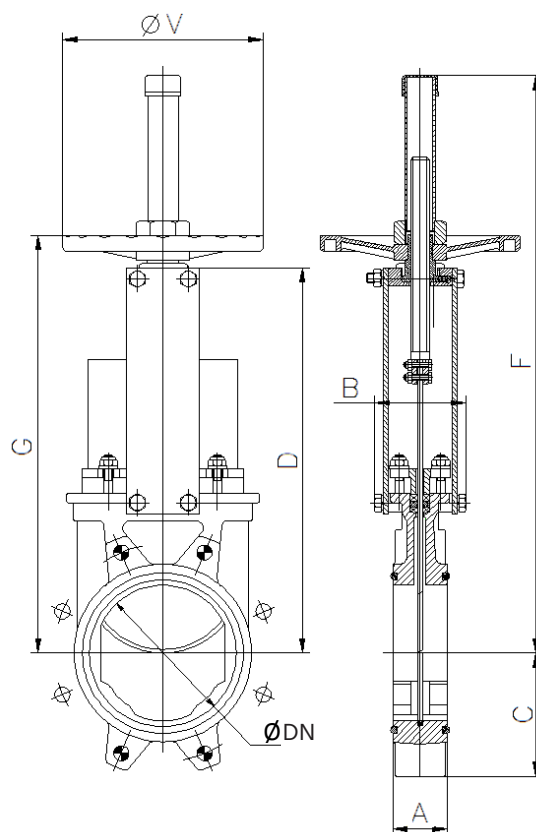

DN	ΔP (Kg/cm ²)	axial force (Nw)	torque (Nm)	A	B	C	D	F	G	ØV	kg
50	10	1143	2,64	40	91	61	241	410	280	225	7
65	10	1952	4,45	40	91	68	268	437	308	225	8
80	10	2957	6,76	50	91	91	294	463	333	225	9
100	10	4617	10,5	50	91	104	334	503	373	225	11
125	10	7213	16,5	50	101	118	367	586	407	225	13
150	10	7290	16,6	60	101	130	419	638	458	225	17
200	8	12975	37,1	60	118	159	525	816	578	325	28
250	6	14522	41,4	70	118	196	626	1017	679	325	40
300	6	20942	59,8	70	118	230	726	1117	779	380	56
350	5	22810	88,5	96	290	254	797	1337	906	450	94
400	5	29879	115,9	100	290	287	903	1443	1012	450	116
450	3	28461	110,3	106	290	304	989	1629	1098	450	162
500	3	35333	137,1	110	290	340	1101	1741	1210	450	178
600	3	51235	198,6	110	292	398	1307	2047	1416	450	260

Serie AB with chain wheel

Fig. 4

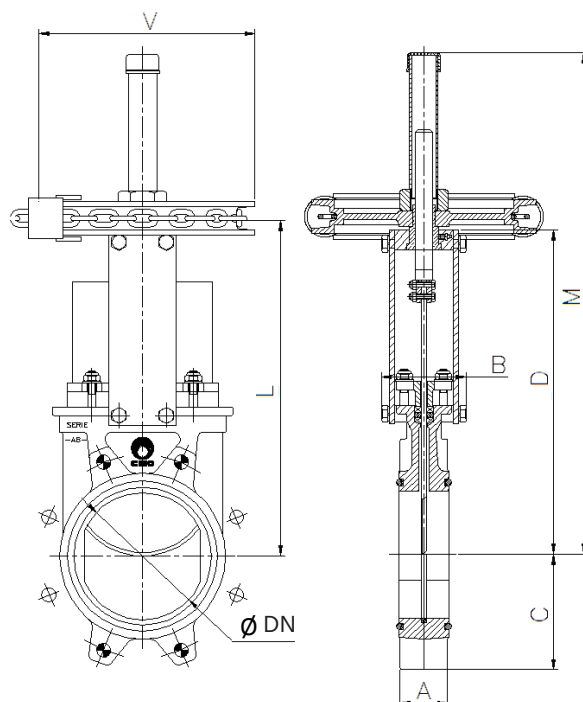

DN	ΔP (Kg/cm ²)	axial force (Nw)	torque (Nm)	A	B	C	D	L	M	ØV	kg
50	10	1143	2,64	40	91	61	241	280	410	225	7
65	10	1952	4,45	40	91	68	268	308	437	225	8
80	10	2957	6,76	50	91	91	294	333	463	225	9
100	10	4617	10,5	50	91	104	334	373	503	225	11
125	10	7213	16,5	50	101	118	367	407	586	225	13
150	10	7290	16,6	60	101	130	419	458	638	225	17
200	8	12975	37,1	60	118	159	525	578	816	300	28
250	6	14522	41,4	70	118	196	626	679	1017	300	40
300	6	20942	59,8	70	118	230	726	779	1117	300	56
350	5	22810	88,5	96	290	254	797	906	1337	402	94
400	5	29879	115,9	100	290	287	903	1012	1443	402	116
450	3	28461	110,3	106	290	304	989	1098	1629	402	162
500	3	35333	137,1	110	290	340	1101	1210	1741	402	178
600	3	51235	198,6	110	292	398	1307	1416	2047	402	260

Serie A with quick-closing lever

Fig. 5

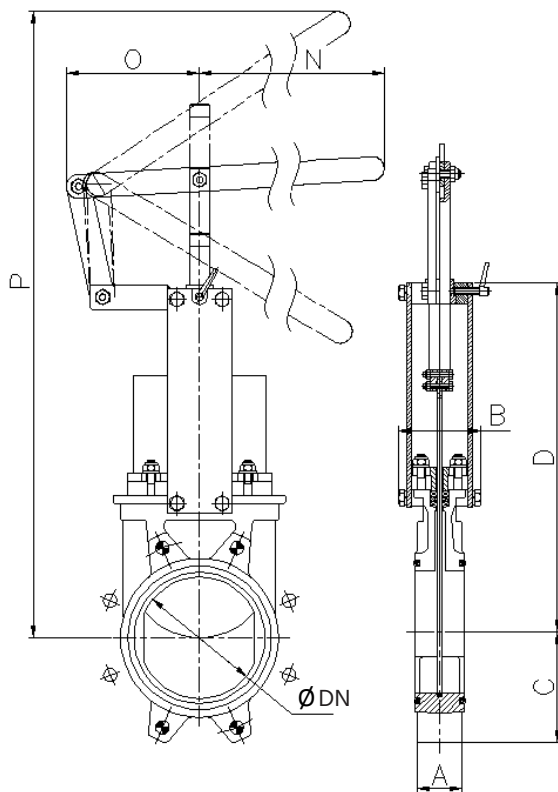

DN	ΔP (Kg/cm ²)	axial force (Nw)	A	B	C	D	N	O	P	kg
50	10*	241*	40	91	61	241	325	155	504	9
65	10*	406*	40	91	68	268	325	155	526	10
80	10*	613*	50	91	91	294	325	155	549	11
100	10*	954*	50	91	104	334	325	155	605	13
125	10*	1494*	50	101	118	367	425	155	902	16
150	10*	2151*	60	101	130	419	425	155	956	20
200	8*	3832*	60	118	159	525	620	290	1027	32

*) Lever is designed to operate up to 2 kg / cm² of differential pressure.

Serie AB with gear box

Fig. 6

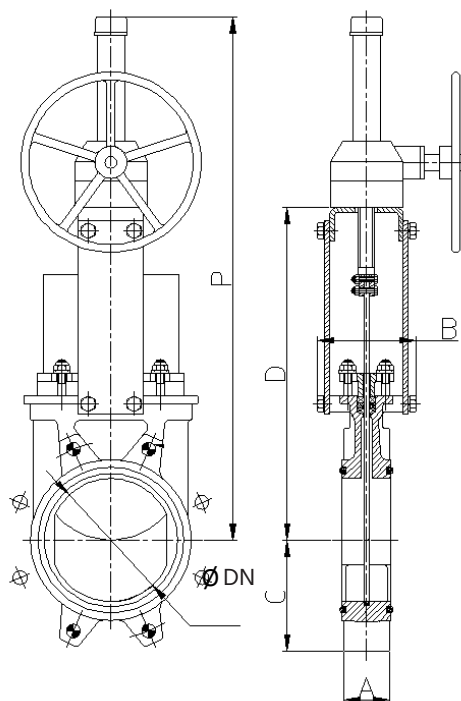

DN	ΔP (Kg/cm ²)	axial force (Nw)	torque (Nm)	A	B	C	D	P	kg
50	10	1143	2,64	40	91	61	241	540	20
65	10	1952	4,45	40	91	68	268	566	21
80	10	2957	6,76	50	91	91	294	592	22
100	10	4617	10,5	50	91	104	334	632	24
125	10	7213	16,5	50	101	118	367	665	26
150	10	7290	16,6	60	101	130	419	717	30
200	8	12975	37,1	60	118	159	525	942	41
250	6	14522	41,4	70	118	196	626	1033	53
300	6	20942	59,8	70	118	230	726	1121	69
350	5	22810	88,5	96	290	254	797	1305	107
400	5	29879	115,9	100	290	287	903	1403	130
450	3	28461	110,3	106	290	304	989	1677	183
500	3	35333	137,1	110	290	340	1101	1789	204
600	3	51235	198,6	110	290	398	1307	1995	288

Serie AB with double-acting pneumatic actuator

Fig. 7

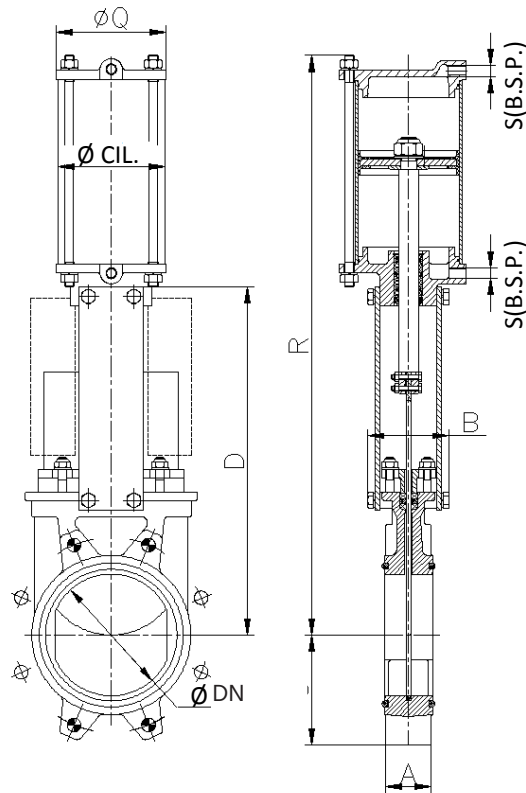

DN	ΔP (Kg/cm ²)	axial force (Nw)	A	B	C	D	R	Ø cylinder	Ø piston rod	Ø Q	S (B.S.P.)	kg
50	10	1143	40	91	61	241	400	80	20	90	1/4"	7
65	10	1952	40	91	68	268	442	80	20	90	1/4"	8
80	10	2957	50	91	91	294	483	80	20	110	1/4"	9
100	10	4617	50	91	104	334	546	100	20	135	1/4"	12
125	10	7213	50	101	118	367	630	125	25	170	1/4"	18
150	10	7290	60	101	130	419	692	125	25	170	1/4"	22
200	8	12975	60	118	159	525	869	160	30	215	1/4"	37
250	6	14522	70	118	196	626	1032	200	30	270	3/8"	58
300	6	20942	70	118	230	726	1182	200	30	270	3/8"	72
350	5	22810	96	290	254	797	1379	250	40	382	3/8"	130
400	5	29879	100	290	287	903	1535	250	40	382	3/8"	148
450	3	28461	106	290	304	989	1677	300	45	382	1/2"	235
500	3	35333	110	290	340	1101	1839	300	45	444	1/2"	260
600	3	51235	110	290	398	1307	2145	300	45	508	1/2"	334

Note: The control air pressure of a standard pneumatic actuator is in the range of 6–10 kg / cm². In order to design a suitable pneumatic if the control air pressure is less than 6 bar, please contact our sales department.

Serie AB with single-acting pneumatic actuator

Fig. 8

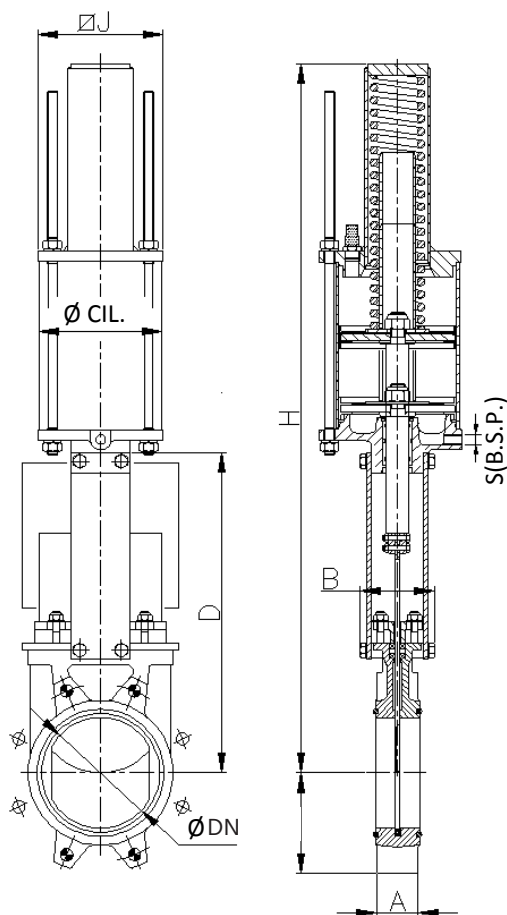

DN	ΔP (Kg/cm ²)	axial force (Nw)	torque (Nm)	A	B	C	D	H	ØJ	Ø cylinder	Ø piston rod	S (B.S.P.)	kg
50	10	1143	2,64	40	91	61	241	781	135	125	25	1/4"	19
65	10	1952	4,45	40	91	68	268	806	135	125	25	1/4"	22
80	10	2957	6,76	50	91	91	294	833	135	125	25	1/4"	23
100	10	4617	10,5	50	91	104	334	873	135	125	25	1/4"	24
125	10	7213	16,5	50	101	118	367	909	135	160	30	1/4"	35
150	10	7290	16,6	60	101	130	419	960	135	160	30	1/4"	36
200	8	12975	37,1	60	118	159	525	1355	170	200	30	3/8"	66

Note: The control air pressure of a standard pneumatic actuator is in the range of 6–10 kg / cm². In order to design a suitable pneumatic if the control air pressure is less than 6 bar, please contact our sales department

Serie AB with electric actuator

Fig.9

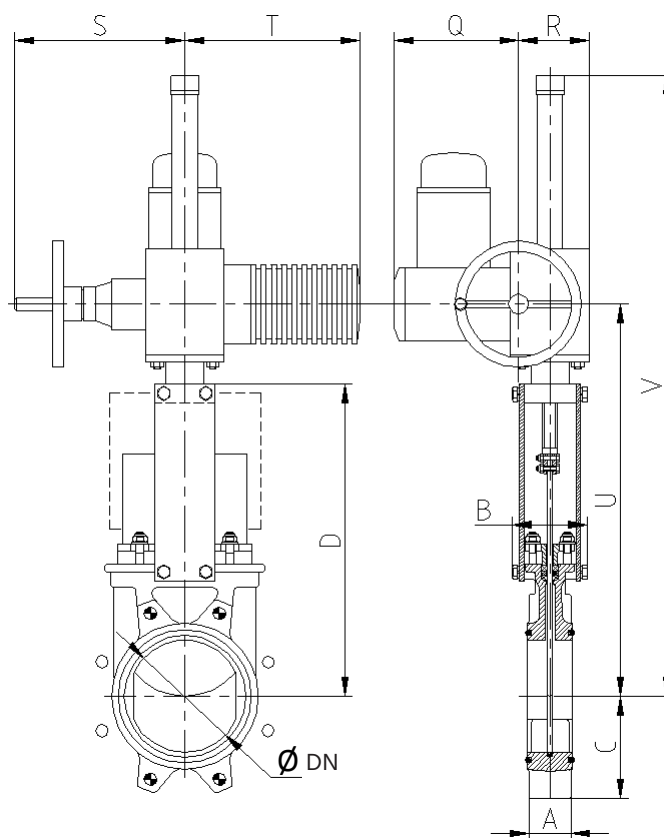

DN	ΔP (Kg/cm ²)	axial force (Nw)	torque (Nm)	A	B	C	D	Q	R	S	T	U	V	S	kg
50	10	1 143	2,64	40	91	61	241	197	102	234	265	347	587	234	24
65	10	1 952	4,45	40	91	68	268	197	102	234	265	374	614	234	25
80	10	2 957	6,76	50	91	91	294	197	102	234	265	400	640	234	26
100	10	4 617	10,5	50	91	104	334	197	102	234	265	440	680	234	27
125	10	7 213	16,5	50	101	118	367	197	102	234	265	473	713	234	30
150	10	7 290	16,6	60	101	130	419	197	102	234	265	525	765	234	32
200	8	12 975	37,0	60	118	159	525	197	102	234	265	640	880	234	42
250	6	14 522	41,1	70	118	196	626	197	102	234	265	741	981	234	55
300	6	20 942	59,8	70	118	230	726	197	102	234	265	841	1 141	234	72
350	5	22 810	88,5	96	290	254	797	197	115	256	282	844	1 347	256	99
400	5	29 879	115,9	100	290	287	903	197	115	256	282	1 050	1 550	256	136
450	3	28 461	110,3	106	290	304	989	222	153	325	385	1 147	1 847	325	166
500	3	35 333	137,1	110	290	340	1 101	222	153	325	385	1 259	1 959	325	245
600	3	51 235	198,6	110	290	398	1 307	222	153	325	385	1 465	2 165	325	362

DIMENSIONS FOR ASSEMBLY BETWEEN FLANGES

DN	ΔP (Kg/cm ²)	○	●	M screw	P	ØK
50	10	4	-	M 16	8	125
65	10	4	-	M 16	8	145
80	10	4	4	M 16	9	160
100	10	4	4	M 16	9	180
125	10	4	4	M 16	9	210
150	10	4	4	M 20	10	240
200	8	4	4	M 20	10	295
250	6	6	6	M 20	12	350
300	6	6	6	M 20	12	400
350	5	12	4	M 20	21	460
400	5	12	4	M 24	21	515
450	3	16	4	M 24	22	565
500	3	16	4	M 24	22	620
600	3	16	4	M 27	22	725

Fig. 10

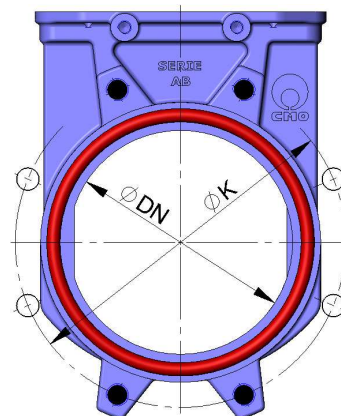

- through holes
- blind holes

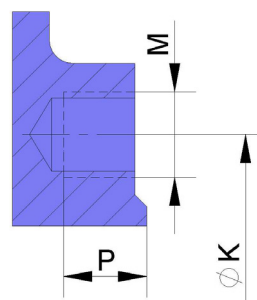

The data in the catalog are informative and the supplier reserves the right to make technical changes.